

# A

**A-Series**

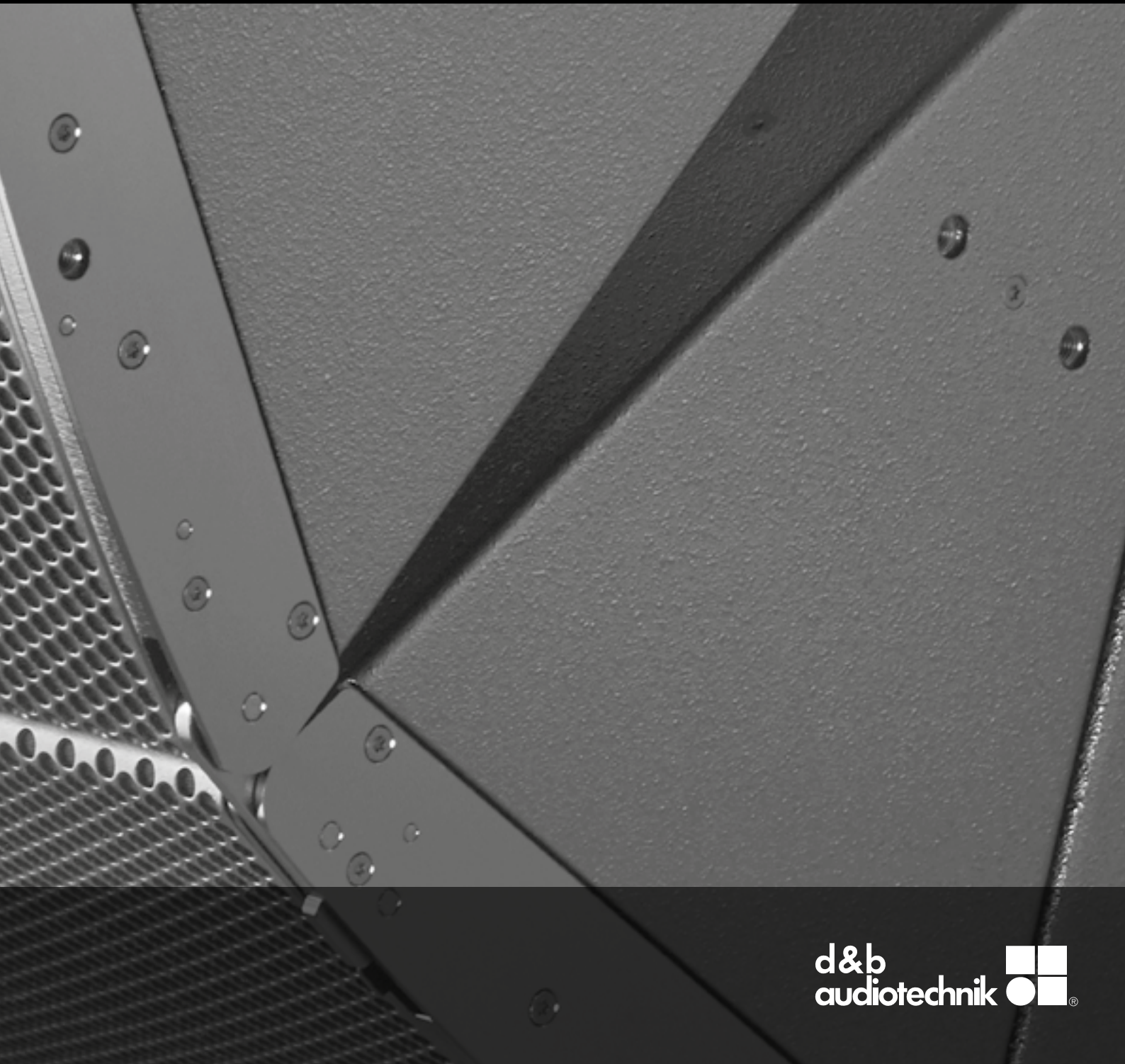

# Contents

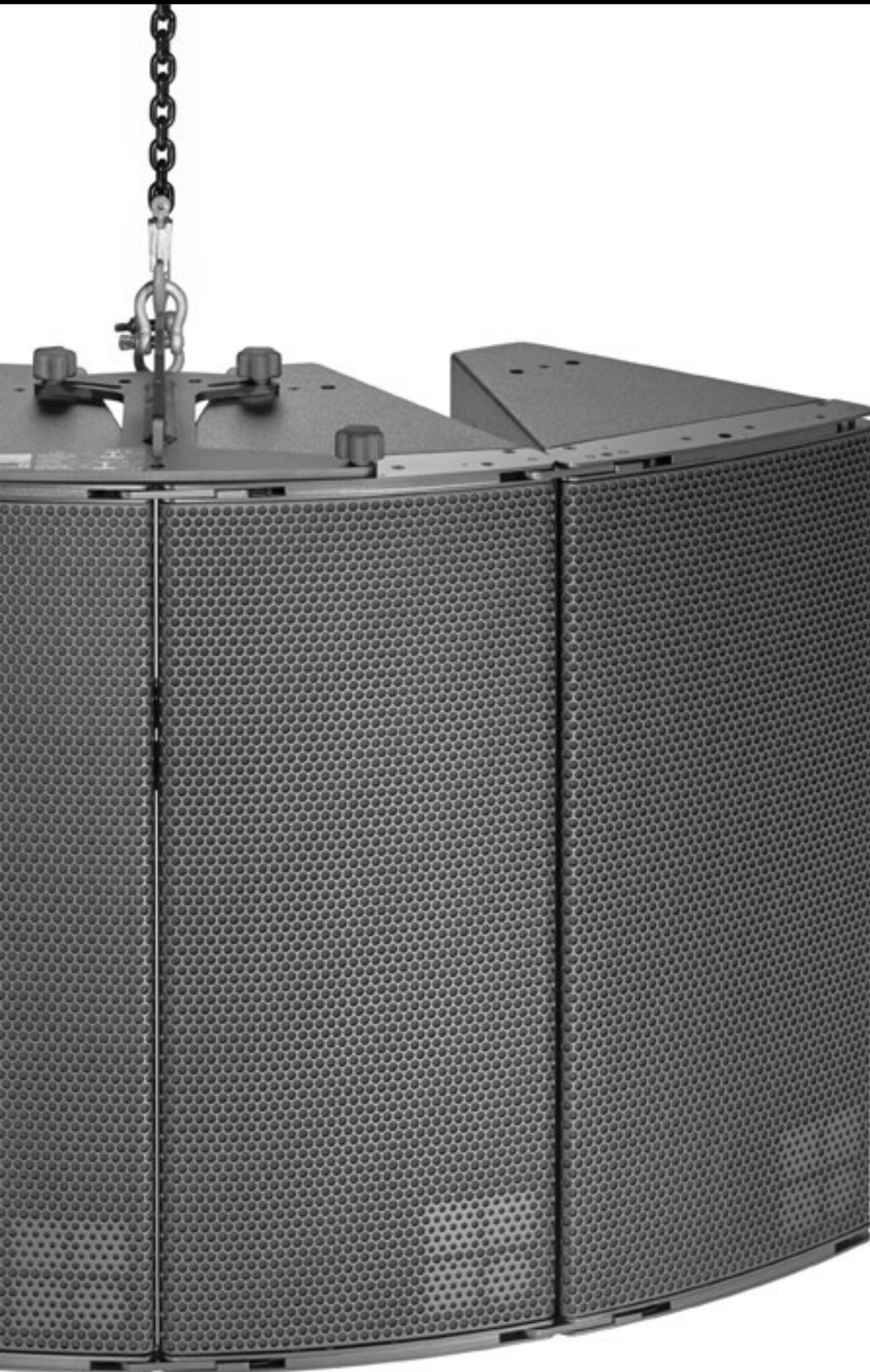

<b>The d&amp;b System reality</b> .....	4
<b>The A-Series</b> .....	6
<b>The AL60 and ALi60 loudspeakers</b> .....	10
<b>The AL90 and ALi90 loudspeakers</b> .....	11
<b>The V-GSUB</b> .....	12
<b>The Vi-GSUB</b> .....	13
<b>The A-Series Weather Resistant, Special Colour and Custom solutions options</b> .....	14
<b>The A-Series case</b> .....	15
<b>The A-Series mounting accessories</b> .....	16
<b>The A-Series mounting examples</b> .....	17
<b>The d&amp;b ArrayCalc simulation software</b> .....	18
<b>The d&amp;b NoizCalc immission modelling software</b> .....	20
<b>The d&amp;b R1 Remote control software</b> .....	21
<b>The d&amp;b amplifiers</b> .....	22
<b>The controller setups and operation with d&amp;b amplifiers</b> .....	24
<b>The A-Series frequency responses</b> .....	25
<b>The d&amp;b amplifier output modes</b> .....	26
<b>The DS10 and DS20 Audio network bridges</b> .....	28
<b>The DS100 Signal Engine</b> .....	28
<b>The A-Series configuration examples</b> .....	29
<b>The A-Series cables and adapters</b> .....	32
<b>The A-Series product overview</b> .....	34

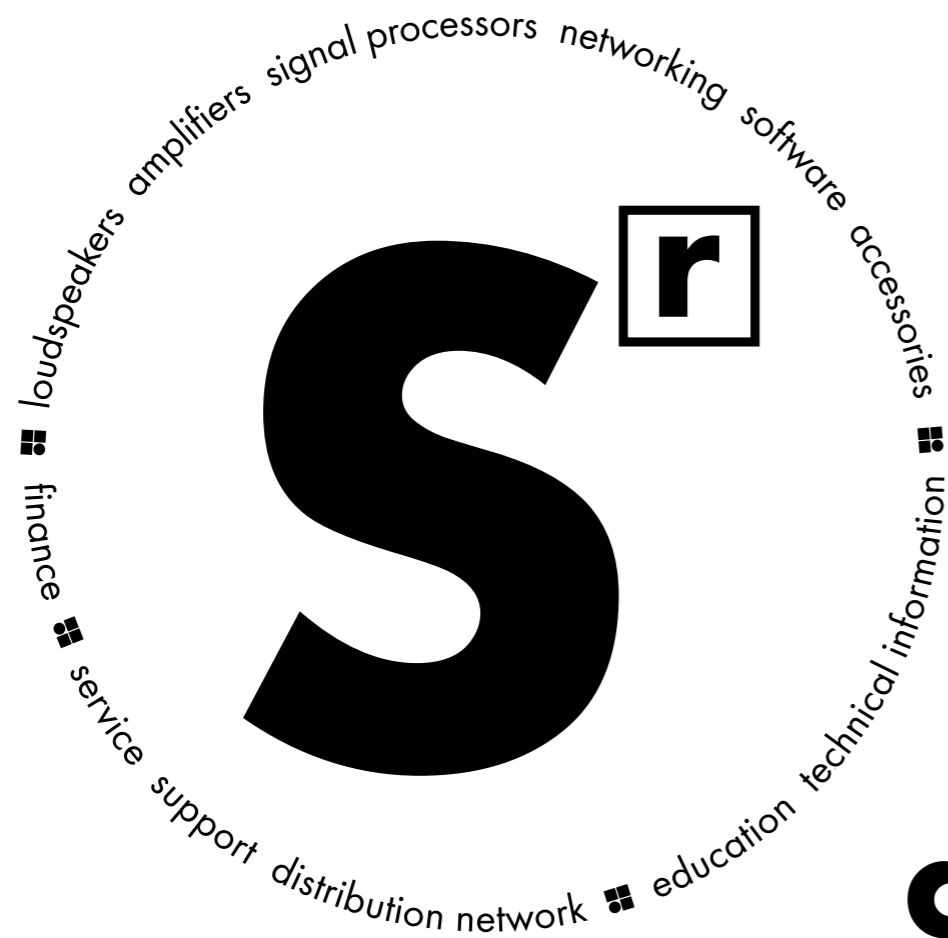

# d&b System reality

As the name implies a d&b audiotechnik system is not just a loudspeaker. Nor is it merely a sum of the components: loudspeakers, amplifiers, signal processors, networking, software and accessories. Right from the outset the d&b audiotechnik approach was to build integrated sound reinforcement systems

that actually are more than the combination of parts: an entirety where each fits all. Every element is tightly specified, precisely aligned and carefully matched to achieve maximum efficiency. For ease of use, all the user-definable parameters are incorporated, allowing the possibility of adjustment, either

directly, via remote control surfaces, or integrated within wider networks. Neutral sound characteristics leave the user all the freedom needed to realize whatever the brief. At the same time d&b offers finance, service and support, a knowledgeable distribution network, education and training as well as technical

information, so the same optimal acoustic result is achieved consistently by every system anywhere, at any time. In reality: the d&b System reality.

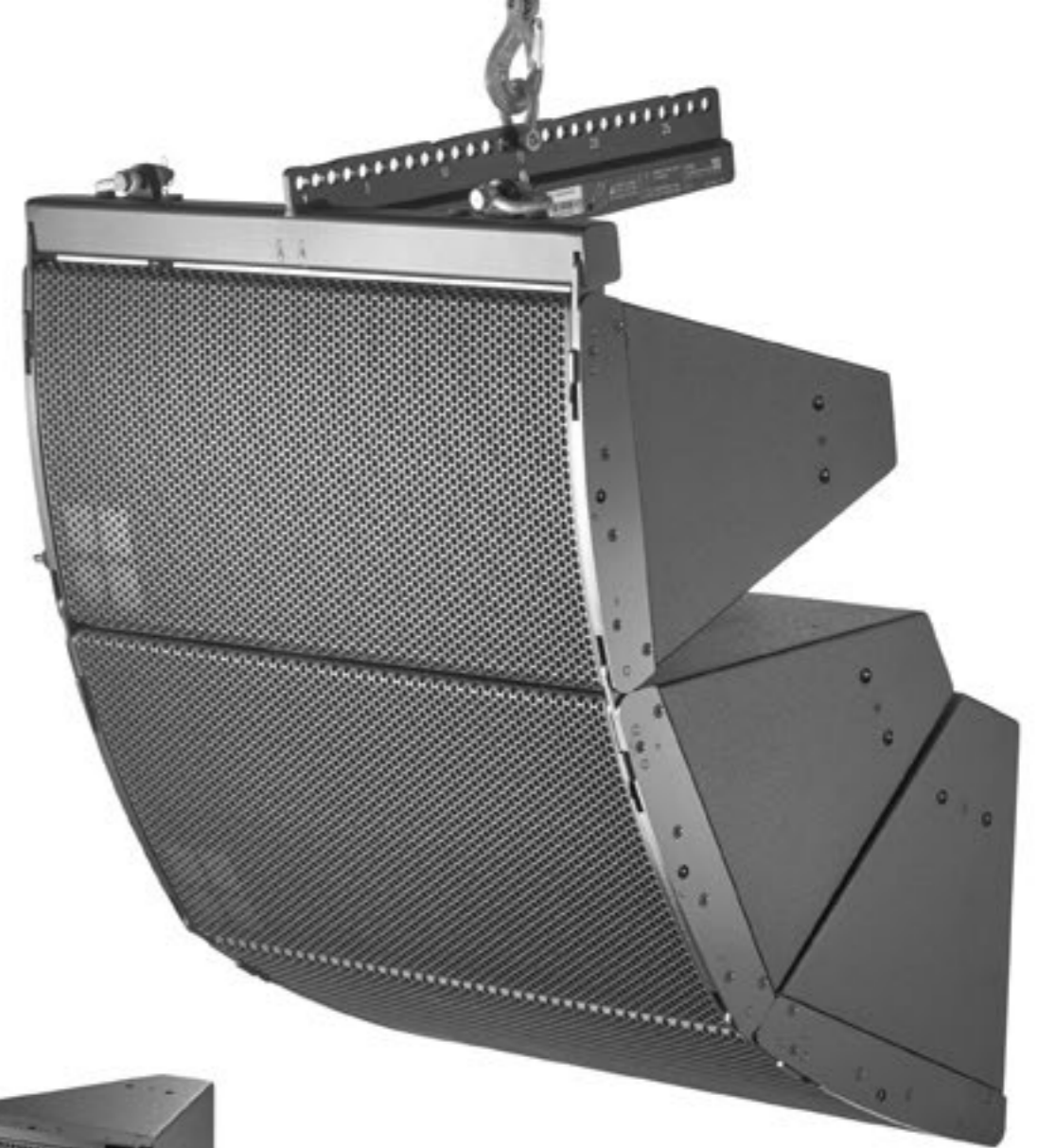
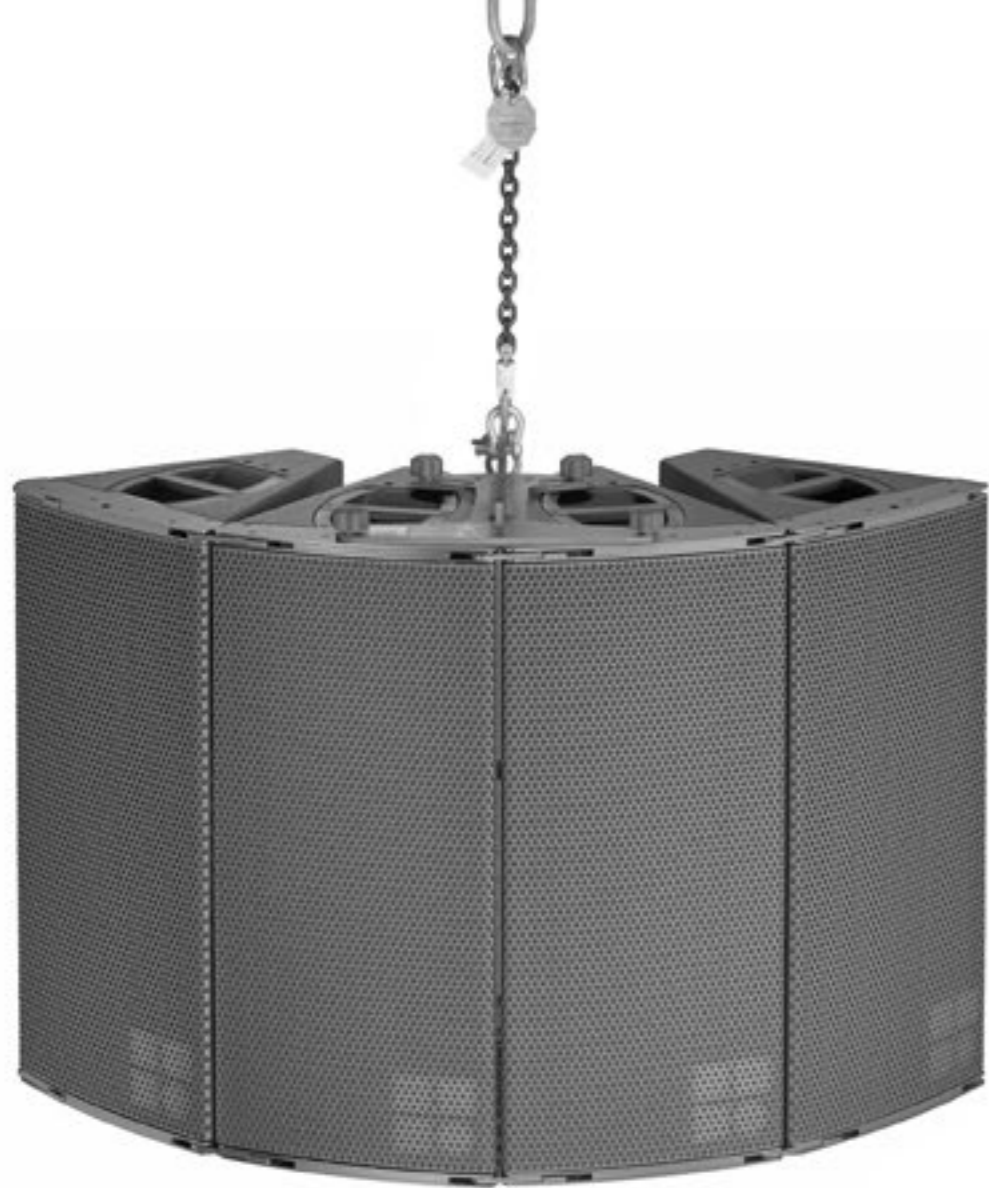

The **A-Series** is a unique new loudspeaker concept that combines advanced waveguide design with d&b enabling technologies to address the broadest range of applications where coverage flexibility is paramount. Right from the outset

the d&b audiotechnik approach was to build integrated sound reinforcement systems that are actually more than the combination of parts. The A-Series expands this idea even further with the introduction of augmented arrays. An unprecedented new

beginning, the A-Series stretches beyond flexibility: Variable splay angles allow the finest of adjustments so that sound is directed only to where it should be. Narrow or broad coverage, horizontal arrays or vertical, using two, three or four loudspeakers per

array. The same optimal acoustic result is achieved consistently anywhere, at any angle. A new class of loudspeaker. A new beginning. A-Series.

# The A-Series

The **AL60/ALi60** and **AL90/ALi90** augmented array loudspeakers are specifically designed for medium scale sound reinforcement. Using the appropriate frame, up to four loudspeakers can be flown either in vertical columns or in horizontal arrays. The passive 2-Way design features one 1.4" exit HF compression driver with a 3" diaphragm mounted to a waveshaping device, and two 10" neodymium LF drivers. The waveguide design and symmetrical dipolar arrangement of the LF drivers allows a smooth overlap of the adjacent frequency bands. The wave segments of each cabinet couple without gaps and sum up coherently. A single A-Series cabinet has a nominal vertical dispersion of 30°. Variable splay angles between adjacent cabinets can be set in a range of +/- 10° in 5° increments resulting in a total coverage of 50° up to 70° for two cabinets. The 60° horizontal directivity pattern of the AL60 is maintained down to approximately 550 Hz, while the output capability can cover a distance range of up to 30 m depending on climatic conditions. The AL90 has a wider horizontal dispersion pattern of 90° and maintains horizontal directivity down to 370 Hz. The AL90 is acoustically and mechanically compatible with the AL60.

The **V-GSUB** and **Vi-GSUB** are recommended for low frequency extension using the A-Series. The V-GSUB and Vi-GSUB are actively driven cardioid subwoofers that require only one amplifier channel. The V-GSUB is intended for ground stacked applications only and shares the same width as the AL60 and AL90 loudspeakers. It houses two long excursion neodymium drivers, an 18" driver in a bass-reflex design facing to the front and a 12" driver in a two chamber bandpass design radiating to the rear. The Vi-GSUB subwoofer can also be flown with the AL60 and AL90 loudspeakers using rigging supplied by d&b Custom solutions.

Other A-Series compatible subwoofers include the cardioid **Y** and **Yi** subwoofers, which both house two long excursion neodymium drivers. The cabinet of the **27S-SUB** and **B4-SUB** both house two long excursion neodymium drivers in an integrated cardioid setup: a 15" driver in a bass-reflex design facing to the front and a 12" driver in a two chamber bandpass design radiating to the rear. The **B6/Bi6-SUB** and the **18S-SUB** each house a single 18" driver, while the larger **21S-SUB** houses a single 21" driver. The **B22-SUB** subwoofer is designed for ground stacked applications, housing two long excursion 18" drivers built into a bandpass horn cabinet design.

Mobile A-Series loudspeakers and compatible subwoofers are finished with a PCP (Polyurea Cabinet Protection) coating that provides resistance for mobile systems to the adverse effects on cabinets in changing outdoor conditions. The installation ALi60 and ALi90 variants have an impact resistant black paint finish.



AL60/90 loudspeaker



ALi60/90 loudspeaker

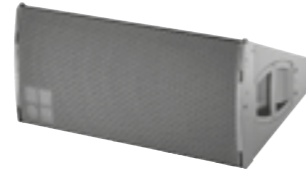

AL60/90 loudspeaker

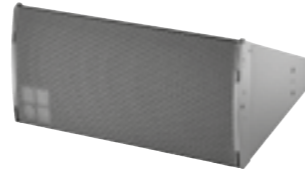

ALi60/90 loudspeaker



V-GSUB

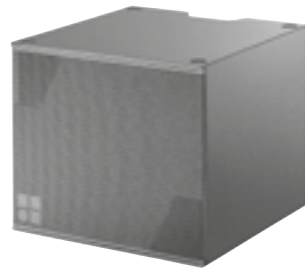

Vi-GSUB

The d&b software offering aides the entire system setup process. The d&b **ArrayCalc** simulation software allows the virtual optimization of loudspeaker line arrays, point source and column loudspeakers as well as subwoofers and their adjustment to venue conditions. The d&b **NoizCalc** immission modelling software uses international standards to model noise immission from one or more d&b loudspeaker systems. NoizCalc takes data from ArrayCalc and calculates the sound propagation towards the far field. The complete system configuration simulated in ArrayCalc is assimilated by the d&b **R1** Remote control software into an intuitive graphical user interface to manage the amplifiers, and loudspeakers, from anywhere in the venue. The **R90** Touchscreen remote control provides quick, reliable, and effortless operation of day-to-day functions of a preconfigured d&b system, without needing expert level knowledge of audio.

The planning process using BIM is supported with Revit files available for all loudspeakers and accessories, creating accurate project data and visualisation.

d&b amplifiers are specifically designed for use with d&b loudspeakers and are at the heart of the d&b system approach. These devices contain extensive Digital Signal Processing capabilities to provide comprehensive loudspeaker management and specific switchable filter functions to precisely target the system response for a wide variety of applications. The four channel **D20** amplifier is specifically designed for mobile events comprising medium sized sound reinforcement solutions. The four channel **D40** and **D80** amplifiers are intended for mobile applications requiring the highest Sound Pressure Levels. The installation specific four channel **30D** and **40D** amplifiers are intended for permanent integration within venues which require medium to high Sound Pressure Levels. These amplifiers all provide extensive user-definable equalization containing two 16-band equalizers with parametric, notch, shelving and asymmetric filters as well as delay capabilities of up to 10 seconds.

The d&b Audio network bridges interface between audio transport networks and AES3 digital audio signals while also providing distribution of Ethernet control data. The **DS10** supports Dante networks, while the **DS20** is used for the open standards-based Milan protocol.

The **DS100** Signal Engine is based on a specialized rack mount 3 RU audio processor with Audinate Dante networking. It provides a 64 x 64 audio matrix with level and delay adjustments at all cross points. Additional software modules provide dynamic source positioning and emulated acoustics functions.



R90 Touchscreen remote control



D20 amplifier



D40 amplifier



D80 amplifier



30D amplifier



40D amplifier



DS10 Audio network bridge



DS20 Audio network bridge



DS100 Signal Engine

# The AL60 and ALi60 loudspeakers

## AL60/ALi60 loudspeaker

The AL60/ALi60 is an augmented array loudspeaker for medium scale sound reinforcement. The ALi60 is the installation version of the AL60 and differs only in cabinet construction and finish. The AL60/ALi60 loudspeaker module is a passive 2-Way design housing 2 x 10" neodymium LF drivers and 1 x 1.4" exit HF compression driver with 3" diaphragms mounted to a dedicated wave shaping device and a passive crossover network. The wave segments of each cabinet couple without gaps and sum up coherently. Splay angles between adjacent cabinets can be set in a range from 20° to 40° in 5° increments resulting in a total coverage of 50° up to 70° for two cabinets, with a maximum total coverage of 150° per array. All components are arranged symmetrically around the center axis of the cabinet to produce a perfect symmetrical dispersion pattern. Broadband horizontal dispersion control is maintained down to approximately 550 Hz. When the AL Flying adapter is used, up to four cabinet modules can be flown in horizontal columns producing a 60° constant directivity dispersion pattern in the vertical plane. AL60/ALi60 can also be applied as vertical array of maximum four loudspeakers using the AL Flying frame.

The cabinet is constructed from marine plywood. The AL60 has an impact and weather protected PCP (Polyurea Cabinet Protection) finish while the ALi60 has an impact resistant black paint finish. The front of the loudspeaker cabinet is protected by a rigid metal grill backed by an acoustically transparent fabric.

## System data AL60 • ALi60

Frequency response (-5 dB standard)..... 60 Hz - 18 kHz  
 Frequency response (-5 dB CUT mode)..... 105 Hz - 18 kHz  
 Max. sound pressure (1 m, free field)<sup>1</sup>.....  
 with D20/30D..... 138 dB  
 with 40D/D40/D80..... 139 dB  
 ..... (SPLmax peak, pink noise test signal with crest factor of 4)

## Loudspeaker data AL60 • ALi60

Nominal impedance..... 8 ohms  
 Power handling capacity (RMS/peak 10 ms)..... 400/1800 W  
 Nominal dispersion angle (h x v - horizontal setup)..... 60° x 30°  
 Components..... 2 x 10" LF driver with neodymium magnet  
 ..... 1 x 1.4" exit compression driver with 3" coil  
 ..... Passive crossover network  
 Connections ..... NLT4 F/M, optional 2 x NL4 M  
 ..... • Phoenix socket (Type: DFK PC 4/4 GF)  
 Pin assignment (AL60)..... NLT4 F/M and NL4 M: 1+/1-  
 Weight..... 23 kg (50.7 lb)

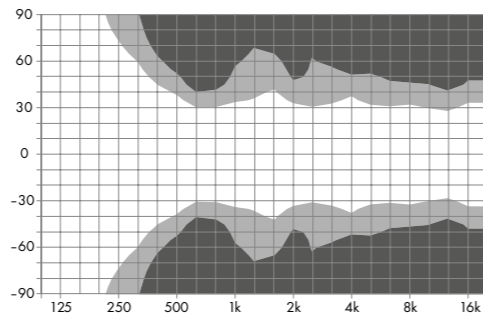

AL60/ALi60 horizontal dispersion characteristics<sup>2</sup>

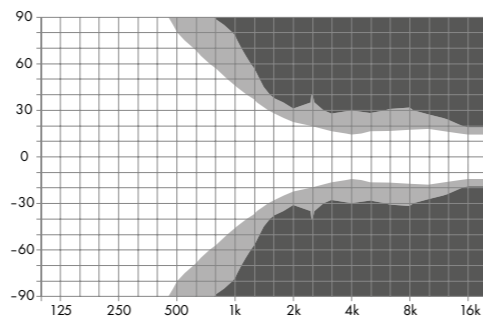

AL60/ALi60 vertical dispersion characteristics<sup>2</sup>

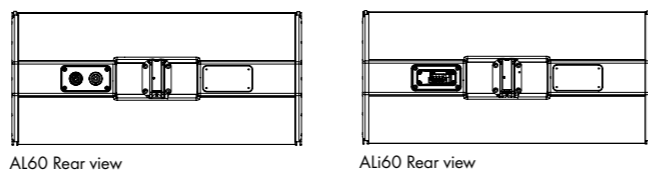
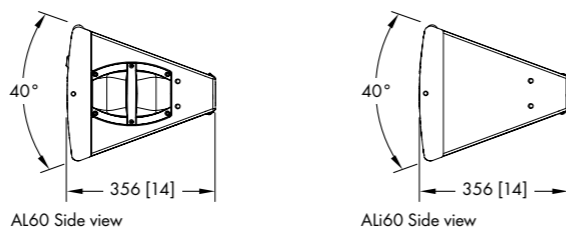
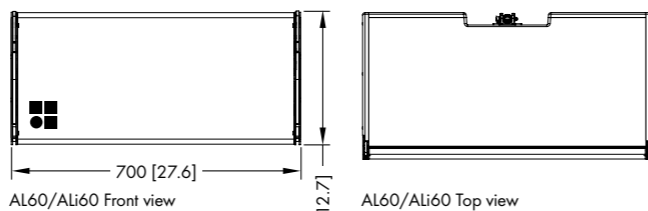

AL60/ ALi60 cabinet dimensions in mm [inch]

<sup>1</sup> Broadband measurement, pink noise, crest factor 4, peak measurement, linear weighting  
<sup>2</sup> Dispersion angle vs frequency plotted using lines of equal sound pressure (isobars) at -6 dB and -12 dB

# The AL90 and ALi90 loudspeakers

## AL90/ALi90 loudspeaker

The AL90/ALi90 is an augmented array loudspeaker for medium scale sound reinforcement. The ALi90 is the installation version of the AL90 and differs only in cabinet construction and finish. The AL90/ALi90 augmented array loudspeaker is a passive 2-way design housing 2 x 10" neodymium LF drivers and 1 x 1.4" exit HF compression driver with 3" diaphragms mounted to a dedicated wave shaping device and a passive crossover network. The wave segments of each cabinet couple without gaps and sum up coherently. Splay angles between adjacent cabinets can be set in a range from 20° to 40° in 5° increments resulting in a total coverage of 50° up to 70° for two cabinets, with a maximum total coverage of 150° per array. All components are arranged symmetrically around the center axis of the cabinet to produce a perfect symmetrical dispersion pattern. Broadband horizontal dispersion control is maintained down to approximately 370 Hz. When the AL Flying adapter is used, up to four cabinet modules can be flown in horizontal columns producing a 90° constant directivity dispersion pattern in the vertical plane. AL90/ALi90 can also be applied as vertical array of maximum four loudspeakers using the AL Flying frame.

The cabinet is constructed from marine plywood. The AL90 has an impact and weather protected PCP (Polyurea Cabinet Protection) finish while the ALi90 has an impact resistant black paint finish. The front of the loudspeaker cabinet is protected by a rigid metal grill backed by an acoustically transparent fabric.

## System data AL90 • ALi90

Frequency response (-5 dB standard)..... 60 Hz - 18 kHz  
 Frequency response (-5 dB CUT mode)..... 105 Hz - 18 kHz  
 Max. sound pressure (1 m, free field)<sup>1</sup>.....  
 with D20/30D..... 138 dB  
 with 40D/D40/D80..... 139 dB  
 ..... (SPLmax peak, pink noise test signal with crest factor of 4)

## Loudspeaker data AL90 • ALi90

Nominal impedance..... 8 ohms  
 Power handling capacity (RMS/peak 10 ms)..... 400/1800 W  
 Nominal dispersion angle (h x v - horizontal setup)..... 90° x 30°  
 Components..... 2 x 10" LF driver with neodymium magnet  
 ..... 1 x 1.4" exit compression driver with 3" coil  
 ..... Passive crossover network  
 Connections ..... NLT4 F/M, optional 2 x NL4 M  
 ..... • Phoenix socket (Type: DFK PC 4/4 GF)  
 Pin assignment (AL90)..... NLT4 F/M and NL4 M: 1+/1-  
 Weight..... 23 kg (50.7 lb)

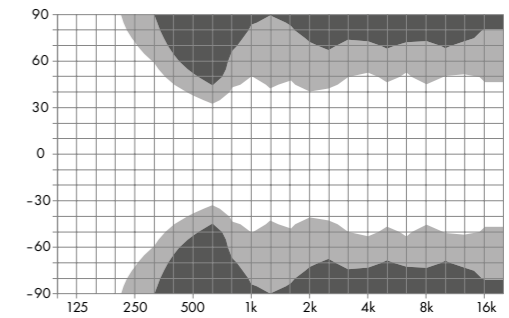

AL90/ALi90 horizontal dispersion characteristics<sup>2</sup>

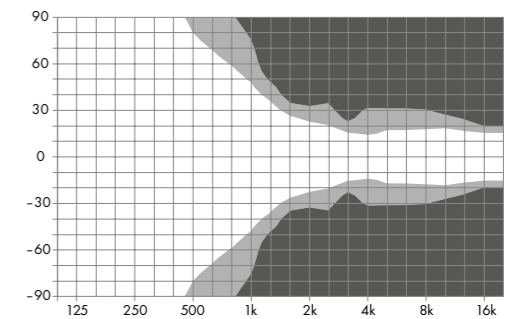

AL90/ALi90 vertical dispersion characteristics<sup>2</sup>

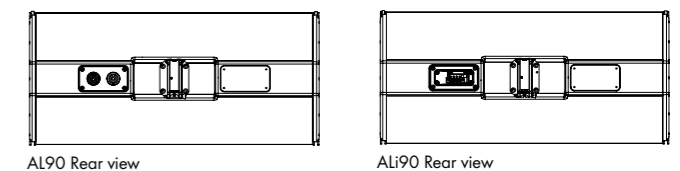
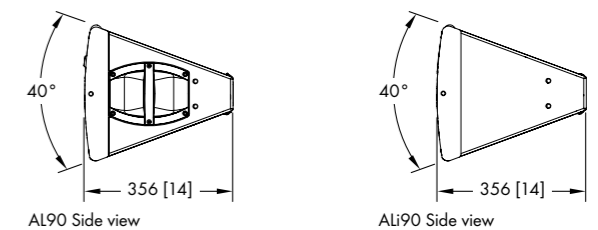
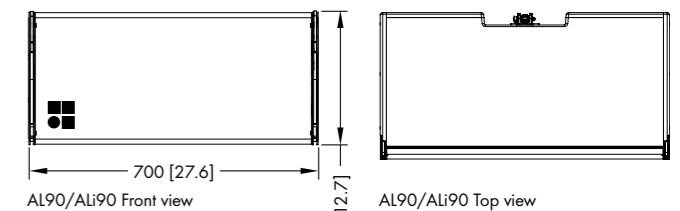

AL90/ ALi90 cabinet dimensions in mm [inch]

<sup>1</sup> Broadband measurement, pink noise, crest factor 4, peak measurement, linear weighting  
<sup>2</sup> Dispersion angle vs frequency plotted using lines of equal sound pressure (isobars) at -6 dB and -12 dB

# The V-GSUB

## V-GSUB

The V-GSUB is an actively driven high performance cardioid subwoofer powered by a single amplifier channel. The V-GSUB is intended for ground stacked applications only, and shares the same acoustical and visual design as the V-SUB, which features integrated rigging equipment. The Vi-GSUB is the installation version of the V-GSUB. It houses two long excursion neodymium drivers, an 18" driver in a bass-reflex design facing to the front and a 12" driver in a two chamber bandpass design radiating to the rear. The cardioid dispersion pattern resulting from this arrangement avoids unwanted energy behind the system that reduces the excitation of the reverberant field at low frequencies and provides the greatest accuracy of low frequency reproduction.

The cabinet is constructed from marine plywood and has an impact and weather protected PCP (Polyurea Cabinet Protection) finish. The front of the loudspeaker cabinet is protected by a rigid metal grill backed by an acoustically transparent foam. The enclosure features two runners to protect the bottom panel from scratching. Two correspondingly shaped recesses are incorporated into the top panel of each V-GSUB cabinet to accept these runners, preventing cabinet movement when stacked. Each side of the V-GSUB panel incorporates two handles whilst the top panel has an M20 high stand flange inserted.

### System data

Frequency response (-5 dB standard)..... 37 Hz - 115 Hz  
 Frequency response (-5 dB 100 Hz mode) ..... 37 Hz - 95 Hz  
 Max. sound pressure (1 m, free field)<sup>1</sup> .....  
 with 30D/D20..... 133 dB  
 with 40D/D40/D80 ..... 137 dB

### Loudspeaker data

Nominal impedance..... 8 ohms  
 Power handling capacity (RMS/peak 10 msec) ..... 800/3200 W  
 Components..... 1 x 18" driver  
 ..... 1 x 12" driver  
 Connections ..... 2 x NL4 F/M  
 ..... optional 2 x NL4  
 Weight..... 61 kg (135 lb)

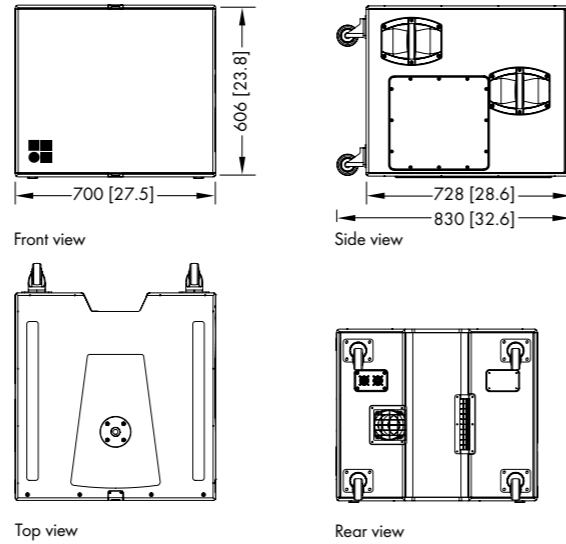

V-GSUB cabinet dimensions in mm [inch]

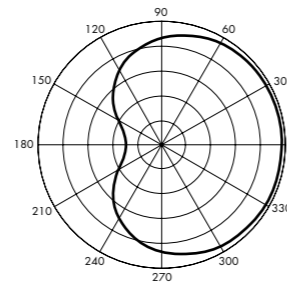

Cardioid polar pattern

# The Vi-GSUB

## Vi-GSUB

The Vi-GSUB is an actively driven high performance cardioid subwoofer powered by a single amplifier channel. The Vi-GSUB is intended for ground stacked applications only, and shares the same acoustical and visual design as the Vi-SUB, which features integrated rigging equipment. It houses two long excursion neodymium drivers, an 18" driver in a bass-reflex design facing to the front and a 12" driver in a two chamber bandpass design radiating to the rear. The cardioid dispersion pattern resulting from this arrangement avoids unwanted energy behind the system that reduces the excitation of the reverberant field at low frequencies and provides the greatest accuracy of low frequency reproduction.

The cabinet is constructed from marine plywood. The front of the loudspeaker cabinet is protected by a rigid metal grill backed by an acoustically transparent foam.

### System data

Frequency response (-5 dB standard)..... 37 Hz - 115 Hz  
 Frequency response (-5 dB 100 Hz mode)..... 37 Hz - 95 Hz  
 Max. sound pressure (1 m, free field)<sup>1</sup> .....  
 with 30D/D20..... 133 dB  
 with 40D/D40/D80 ..... 137 dB

### Loudspeaker data

Nominal impedance..... 8 ohms  
 Power handling capacity (RMS/peak 10 msec) ..... 800/3200 W  
 Components..... 1 x 18" driver  
 ..... 1 x 12" driver  
 Connections ..... 2 x NL4  
 ..... screw terminal block  
 Weight..... 58 kg (128 lb)

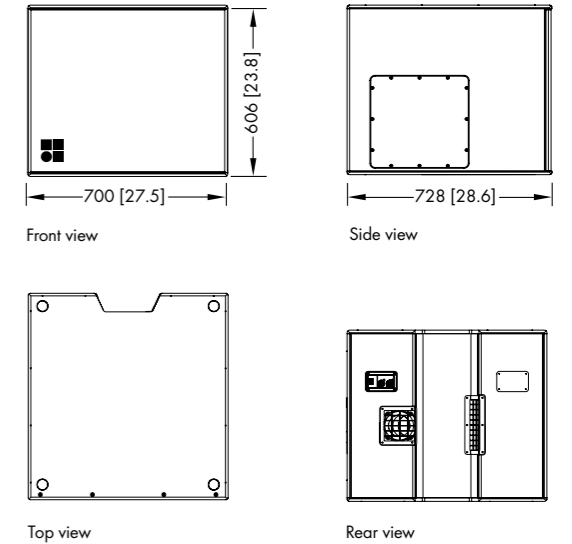

Vi-GSUB cabinet dimensions in mm [inch]

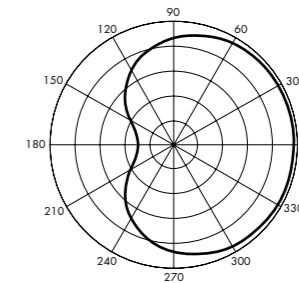

Cardioid polar pattern

# The A-Series Weather Resistant, Special Colour and Custom solutions options

## Weather Resistant (WR) option

The WR option provides an IP54 rating, and enables operation of loudspeakers in changing ambient conditions, with some loudspeakers able to achieve an IP55 rating. However it is not intended to enable permanent, unprotected operation of loudspeakers outdoors. Cabinets used outdoors even with the WR option should always be aimed either horizontally or with a downward tilt. All WR speakers will be delivered without a cable.

## Special Colour (SC) option

The paint finish of all loudspeaker cabinets and most accessories can be executed in almost any custom colour in accordance with common colour tables. All rigging fittings at the rear of the cabinet, Front links and Locking pins remain in black. Other paint finishes such as metallic are available on request. The acoustically transparent foam fitted behind the rigid metal grill is also painted with the requested special colour.

## Custom solutions (SVS and SWR) option

SVS (Variants For Stadiums) loudspeakers have no integral rigging components, but instead, have threaded inserts in their side panels. The cabinets will be mechanically supported by metal brackets specifically designed for the respective application by Custom solutions.

SWR (Sea Water Resistant) loudspeaker models are based on WR or SVS variants where available, and withstand outdoor operation in wet and acid or salty environments like on cruise ships or coastal locations. Other custom solutions are available upon request.

# The A-Series case

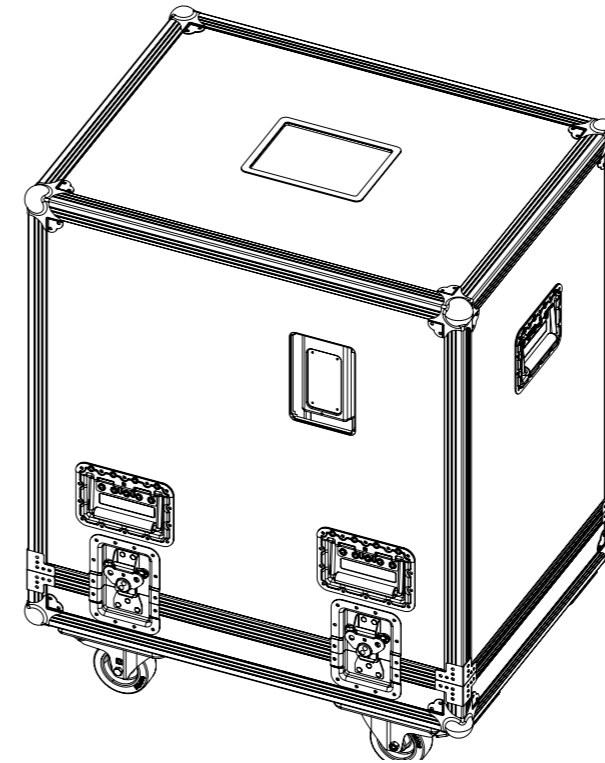

**E7927.000**  
Touring case 2 x AL60/90

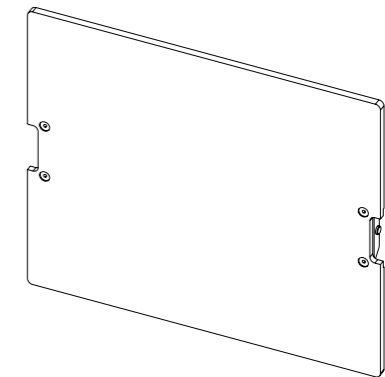

**E7923**  
V-GSUB Wooden lid

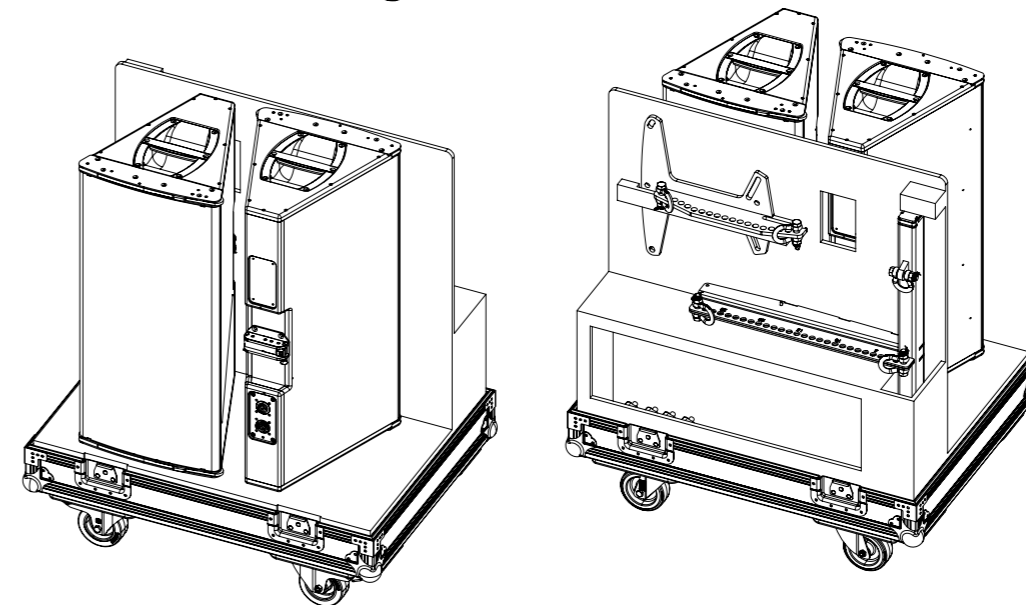

**E7927.000**  
Touring case interior view



# The A-Series mounting accessories

# The A-Series mounting examples

## Safety approval

d&b loudspeakers and accessories are designed for setup and use within situations requiring compliance with the provisions and directives of the DGUV regulation 17 (formerly BGV C1).

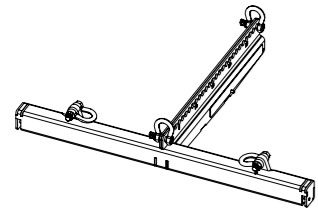

**Z5455**  
AL Flying frame  
Includes Z5454 AL Safety chain

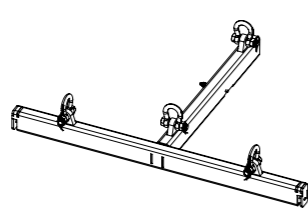

**Z5459**  
ALi Flying frame top

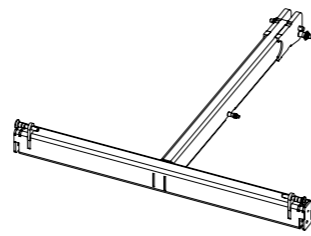

**Z5461**  
AL V-SUB adapter

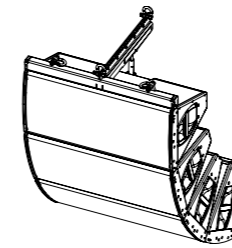

AL Array with  
Z5455 AL Flying frame

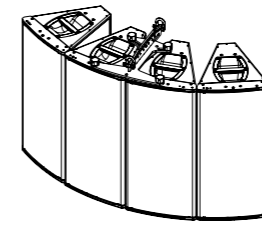

AL Array with  
Z5456 AL Flying adapter

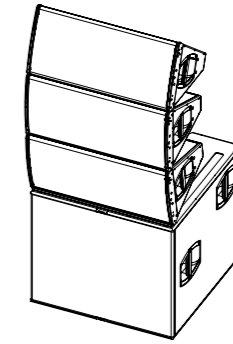

AL Groundstack with  
V-GSUB and  
Z5458 AL Base plate

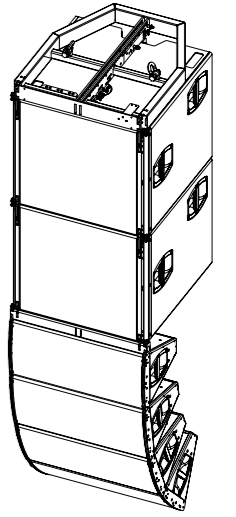

AL Mixed Array with  
V-SUB/AL60/AL90 and  
Z5380 V Flying frame and  
Z5461 AL V-SUB adapter

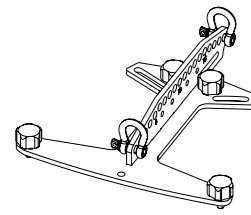

**Z5456**  
AL Flying adapter

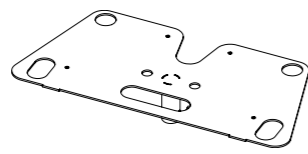

**Z5460**  
AL Stand adapter

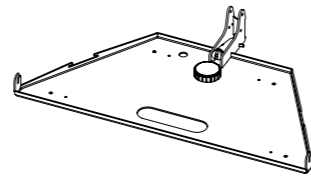

**Z5458**  
AL Base plate

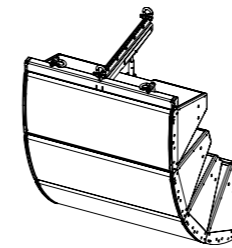

ALi Array with  
Z5455 AL Flying frame

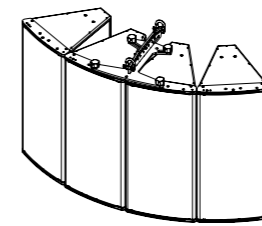

ALi Array with  
Z5456 AL Flying adapter

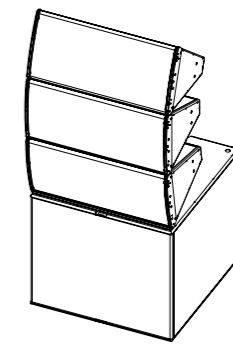

ALi Groundstack with  
Vi-GSUB and  
Z5458 AL Base plate

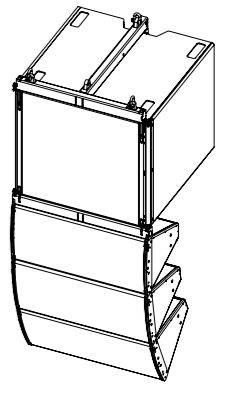

ALi Mixed Array with  
Vi-SUB/ALi60/ALi90 and  
Z5387 Vi Mounting frame  
top and  
Z5461 AL V-SUB adapter

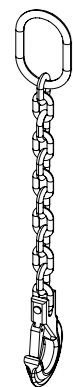

**Z5453**  
AL Hoist connector chain



**Z5454**  
AL Safety Chain

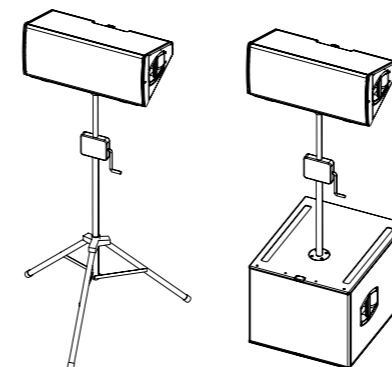

AL Top mounted with  
Z5458 AL Base plate and  
Z5460 AL Stand adapter

# The d&b ArrayCalc simulation software

The d&b ArrayCalc simulation software is the prediction tool for d&b line arrays, column and point source loudspeakers as well as subwoofers. This is a comprehensive toolbox for all tasks associated with acoustic design, performance prediction, alignment, rigging and safety parameters. For safety reasons d&b line arrays must be designed using the d&b ArrayCalc simulation software. ArrayCalc is available as a native stand-alone application for both Microsoft Windows<sup>1</sup> (Win7 64-bit or later) and Mac OS X<sup>2</sup> (10.12 or later) operating systems. In combination with the d&b Remote Network, this can significantly reduce setup and tuning time in mobile applications and allows for precise simulations when planning installations. Listening planes can be defined in the venue tab, creating a three dimensional representation of any audience area in a given venue. This can also include balconies, side stalls, arenas, in the round scenarios or festivals. Special functions assist in obtaining accurate dimensions with laser distance finders and inclinometers.

## Simulation

Up to forty flown arrays or subwoofer columns can be defined in a project file as single hangs or in pairs. A selection of d&b point source loudspeakers can also be fully integrated as well as a ground stacked SUB array consisting of up to eighty positions. All can be freely positioned according to their intended application, for example as main hang, outfill, nearfill or delay. Position, orientation, aiming and coverage details are displayed. Level over distance is calculated for each source with high resolution in real time, for either band limited or broadband input signals. The comprehensive simulation precisely models the actual performance of the system, taking into account input level, all system configuration options (such as CUT, CPL, HFC or INFRA), limiter headroom and air absorption. Acoustic obstacles, such as video screens, can be added to a model. Acoustic shadowing, whether by these obstacles, or a balcony overhang, is taken into consideration. The load status of all array rigging components is calculated accurately and displayed to determine whether a given array is within the load tolerance. Subwoofer array design is assisted by coverage and polar plot prediction. A specialized algorithm allows the user to specify subwoofer positions and a coverage angle, which is then converted into appropriate delay settings that result in the desired dispersion. The alignment tab enables different sources to be time aligned to one another, as well as showing arrival times and Sound Pressure Levels at a definable reference point on one of the audience areas. For alignment of the flown system with the ground stacked SUB array, the phase response of both the SUB array and a flown source is calculated at a definable reference point.

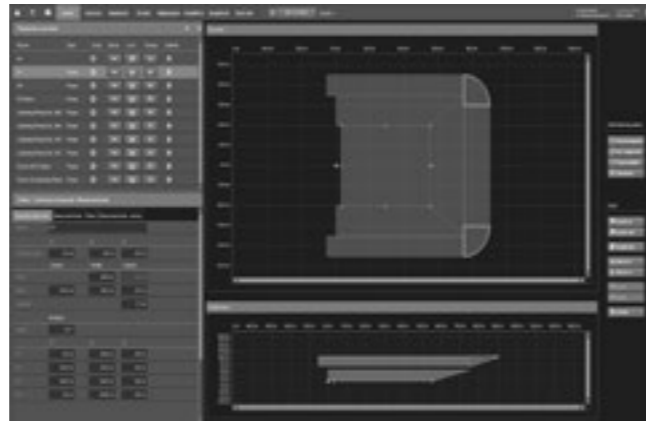

Venue

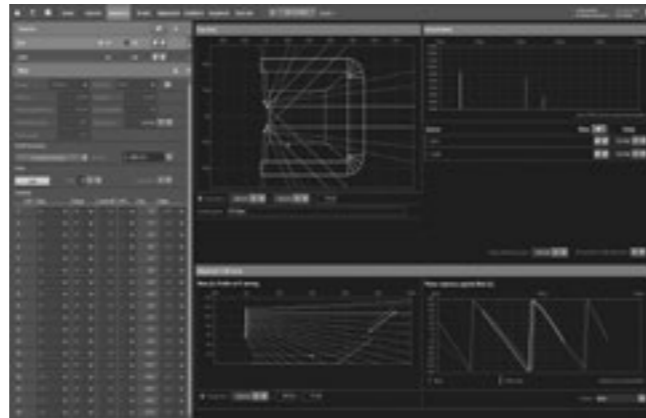

Alignment

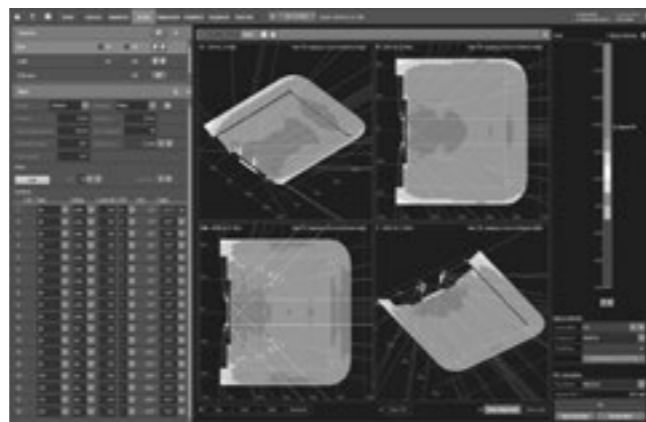

3D Plot quad

Both simulations reflect changes in delay time to the single sources in real time. The d&b ArrayCalc simulation software is available at [www.dbaudio.com](http://www.dbaudio.com).

## Prediction

The level distribution resulting from the interaction of all active sources can be mapped onto the audience areas in a three-dimensional view, which can also be zoomed, rotated and exported as a graphics file. EASE and DXF data export capabilities are also available. A rigging plot with all necessary coordinates, dimensions and weights of arrays is generated for export and printing and a parts list, detailing all components required. The d&b ArrayCalc Viewer app presents this key information for positioning and flying a d&b audiotechnik loudspeaker system on a mobile device. Once the system has been designed, calculated and optimized, all relevant project information can be shared via email, AirDrop, or downloaded onto any iOS or Android device.

## ArrayProcessing

The optional ArrayProcessing function applies powerful filter algorithms to optimize the tonal (spectral) and level (spatial) performance of a line array column over the audience area defined by its mechanical vertical coverage angle. Temperature and Humidity Control (THC) for ArrayProcessing introduces a workflow that permits a system to adapt to changing atmospheric conditions in real time via R1. Within the d&b ArrayCalc simulation software, spectral and level performance targets over the listening areas can be defined while specific level drops or offsets can be applied to certain areas, to assign reduced level zones. ArrayProcessing applies a combination of FIR and IIR filters to each individual cabinet in an array to achieve the targeted performance, with an additional latency of only 5.9 ms. This significantly improves the linearity of the response over distance as well as seamlessly correcting for air absorption. In addition, ArrayProcessing employs the same frequency response targets for all d&b line arrays, to ensure all systems share a common tonality. The resulting coverage is enhanced with spectral consistency and defined level distribution, achieving more linear dispersion and total system directivity to cover longer distances or steep listening areas effectively.

## R1 Remote Control Software

R1 uses the same project file created by ArrayCalc and generates an intuitive graphical user interface including complete details of the simulated system, loudspeakers, amplifiers, remote IDs, groups, ArrayProcessing data and all configuration information. This workflow removes the need to manually transfer data from one software program to the other.

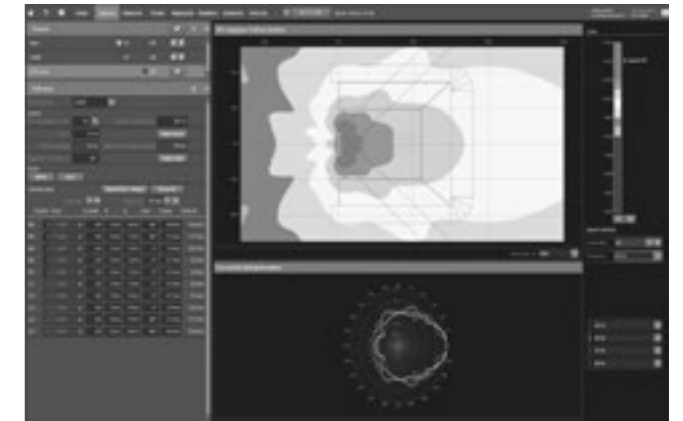

Sources, SUB array

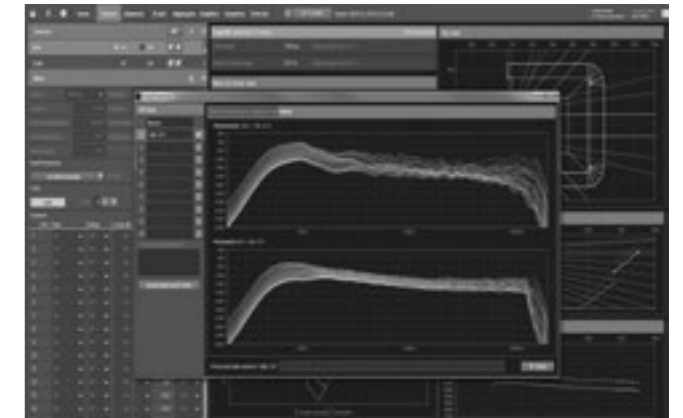

ArrayProcessing

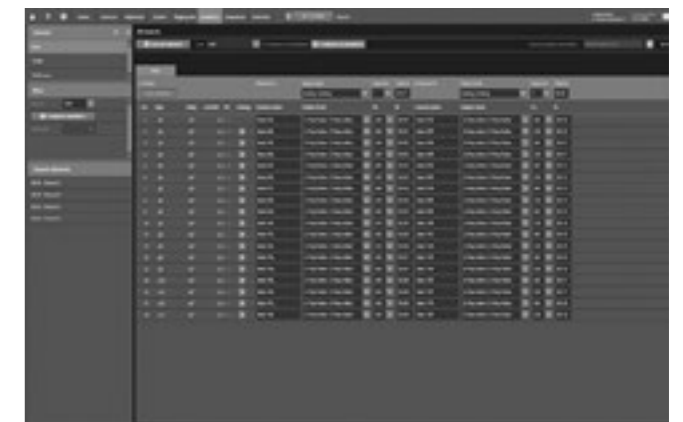

Amplifiers

<sup>1</sup> Microsoft Windows is a registered trademark or trademark of Microsoft Corporation in the United States and/or other countries

<sup>2</sup> Mac OS X is a trademark of Apple Inc., registered in the U.S. and other countries

# The d&b NoizCalc immission modelling software

The d&b software uses international standards to model the far field noise immission from multiple complex and coherently emitting sources such as line arrays and subwoofer arrays. More and more, gaining permission and licenses to stage live open air events requires an official statement with a prediction of how noise could impact on the surrounding area. NoizCalc takes all complex loudspeaker data and a reference point from the d&b ArrayCalc simulation software and calculates the sound propagation and relative attenuation values towards the far field for a certain scenario with particular meteorological conditions for one or more d&b loudspeaker systems.

A 3D terrain map imported from Google Maps or Street View displays the calculated immission on the areas surrounding the audience listening zones. This visual representation shows the actual system performance in the far field, enabling users to optimize for listeners while satisfying local noise restrictions and offsite regulations.

To ensure reliable results, NoizCalc includes all complex data concerning the addition and subtraction of sound waves, including phase information to describe the combination and interaction effects within a loudspeaker system consisting of multiple line arrays, subwoofer arrays and delay systems.

NoizCalc models immissions in the far field according to the internationally accepted ISO 9613-2 or Nord2000 calculation standards. Ground characteristics can be set depending on the absorbency or reflectivity of surfaces, while areas with volume attenuating properties can be defined. Buildings can be included, and the maximum reflection order option adjusts how many reflections are calculated. Parameters for humidity, air pressure and temperature ensure that the correct air absorption figures are accounted. The ISO 9613-2 standard requires limited meteorological information and assumes a worst-case scenario. The more sophisticated propagation model, Nord2000 enables a more precise handling of meteorological conditions allowing the user to model with prevailing wind information. The d&b NoizCalc immission modelling software is available at [www.dbaudio.com](http://www.dbaudio.com) for registered download, along with further information and video tutorials. It was developed in collaboration with SoundPLAN, a specialist software developer for environmental noise prediction.

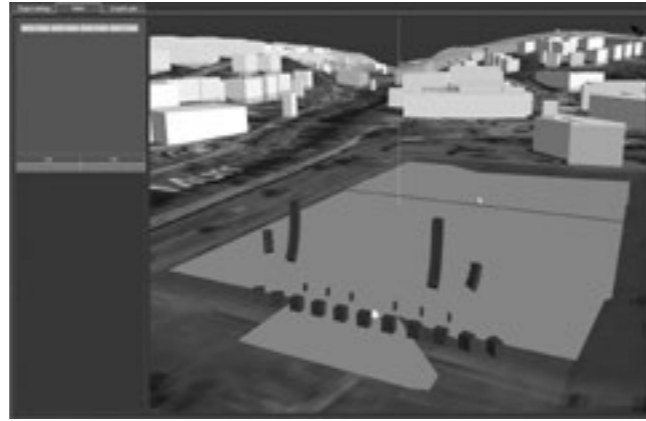

Editor



Graphic plot

# The d&b R1 Remote control software

The remote control capability of the d&b Remote Network enables central control and monitoring of a complete d&b loudspeaker system from anywhere in the network, be it from a computer in the control room, at the mix position, or on a wireless tablet in the auditorium. This central access to all functions throughout the d&b Remote Network unlocks the full potential of the d&b system approach. In a typical user workflow, the d&b Remote Network takes settings optimized in the d&b ArrayCalc simulation software and applies these to all the amplifiers within the network.

All functions and controls available on the front panel of d&b amplifiers may be remotely controlled and/or monitored using the d&b R1 Remote control software. This allows each channel of the amplifier to be controlled and enables the creation of groups of loudspeakers. When grouped together, a button or fader can control the overall system level, zone level, equalization and delay, power ON/OFF, MUTE, as well as loudspeaker specific function switches such as CUT/HFA/HFC and CPL. An offline mode is provided for preparation in advance of an event, without the amplifiers being present or connected.

d&b System check verifies that the system performs within a predefined condition, while the Array verification function automatically identifies the physical position of a loudspeaker in an array to check that the system is cabled correctly. Extensive facilities for storing and recalling system settings are provided allowing these to be repeated, as and when required. For mobile applications, project files can be easily adjusted for use with a different set of equipment at another location.

The R1 software is optimized for use with touch screen, mouse and keyboard and runs on both Microsoft Windows<sup>1</sup> (Win7 64-bit or later) and Mac OS X<sup>2</sup> (10.12 or later).

Further information is provided in the d&b Amplifier and Software brochure which is available for download at [www.dbaudio.com](http://www.dbaudio.com).



R1 home screen



R1 in configuration mode

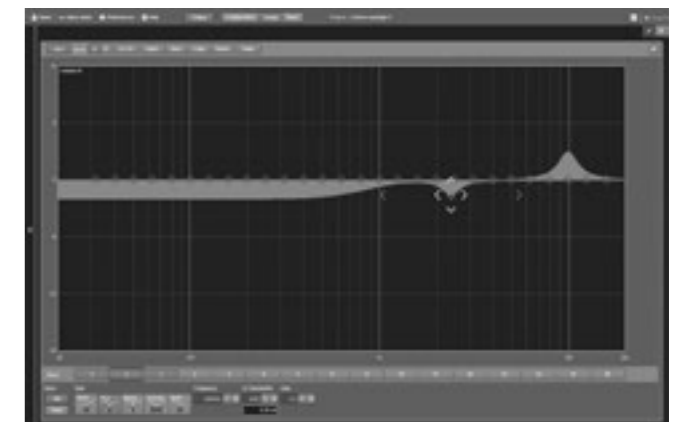

D20/D80 16-band equalizer in R1

<sup>1</sup> Microsoft Windows is a registered trademark or trademark of Microsoft Corporation in the United States and/or other countries

<sup>2</sup> Mac OS X is a trademark of Apple Inc., registered in the U.S. and other countries

# The d&b amplifiers

The d&b amplifiers are designed specifically to power d&b loudspeakers and are the beating heart of the d&b System reality. As such, they incorporate Digital Signal Processing for comprehensive loudspeaker management, switchable filter functions, remote capabilities and user-definable controls, to fulfil the exact needs of each application. Every loudspeaker configuration combines comprehensive system limiting, and equalization and crossover settings to ensure consistent results and optimal performance. d&b amplifiers offer

different output configurations for different loudspeaker setups, including Dual Channel mode, for passive setups, Mix TOP/SUB mode, in which two channels are driven through a single output connector, and 2-Way Active mode, which also sends the output of two channels down one connector to drive appropriate loudspeakers actively. The d&b switch functions provide selected filters to precisely tailor a wide variety of setups to their applications. Examples of these switch functions are the CSA (Cardioid Subwoofer Array)

and HFC (High Frequency Compensation) modes. CSA increases low frequency directivity control by minimising energy transmission towards the rear while HFC compensates for air absorption for loudspeakers covering far field listening positions. In addition to these functions, d&b amplifiers offer a comprehensive set of specific filters such as CUT, a cut mode for TOP loudspeakers when used with d&b subwoofers; CPL, to compensate for the coupling effect between loudspeakers in close proximity to other loudspeakers or hard objects and HFA

mode, to attenuate the high frequencies of a loudspeaker to mimic the effect of far field listening. These devices offer extended, user-definable equalization and delay capabilities, eliminating the need for external processing devices in the signal chain. All d&b amplifiers integrate with the d&b Remote network to enable the remote control and management of systems from anywhere within a network. Further information is provided in the d&b Amplifier and Software brochure which is available for download at [www.dbaudio.com](http://www.dbaudio.com).

## Comparison of the d&b amplifiers

	D20	D40	D80	30D	40D
<b>User interface</b>	Encoder/colour TFT touchscreen	Encoder/colour TFT touchscreen	Encoder/colour TFT touchscreen	LED indicators	Colour TFT touchscreen
<b>Output channels</b>	4	4	4	4	4
<b>Input channels</b>	4 x AES3 or 4 x analog or 2 x AES3 and 2 x analog	4 x AES3 or 4 x analog	4 x AES3 or 4 x analog or 2 x AES3 and 2 x analog	4 x AES3 and 4 x analog	4 x AES3 and 4 x analog
<b>Latency</b>	0.3 msec	0.3 msec	0.3 msec	0.3 msec	0.3 msec
<b>User equalizers (per channel)</b>	2 x 16-band	2 x 16-band	2 x 16-band	2 x 16-band	2 x 16-band
<b>Delay</b>	10 sec/3440 m	10 sec/3440 m	10 sec/3440 m	10 sec/3440 m	10 sec/3440 m
<b>Maximum output power (THD+N &lt; 0.5%, 12 dB crest factor)</b>	4 x 800 W into 8 ohms 4 x 1600 W into 4 ohms	4 x 2000 W into 8 ohms 4 x 2400 W into 4 ohms	4 x 2000 W into 8 ohms 4 x 4000 W into 4 ohms	4 x 800 W into 8 ohms 4 x 1600 W into 4 ohms	4 x 2000 W into 8 ohms 4 x 2400 W into 4 ohms
<b>Output routing</b>	Dual Channel, Mix TOP/SUB 2-Way Active	Dual Channel, Mix TOP/SUB 2-Way Active	Dual Channel, Mix TOP/SUB 2-Way Active	Dual Channel, Mix TOP/SUB 2-Way Active	Dual Channel, Mix TOP/SUB 2-Way Active
<b>Output connectors</b>	NL4 plus central NL8	NL4 plus central NL8	NL4 plus central NL8	Phoenix Euroblock	Phoenix Euroblock
<b>GPIO connector</b>	No	No	No	Phoenix Euroblock 5 ports	Phoenix Euroblock 12 ports
<b>Cable compensation</b>	LoadMatch	LoadMatch	LoadMatch	LoadMatch	LoadMatch
<b>Power supply</b>	Universal range switched mode power supply with active PFC	Autosensing switched mode power supply with active PFC	Autosensing switched mode power supply with active PFC	Universal range switched mode power supply with active PFC	Autosensing switched mode power supply with active PFC
<b>Mains voltage</b>	100 - 240 V, 50 - 60 Hz	100 - 127/208 - 240 V, 50 - 60 Hz	100 - 127/208 - 240 V, 50 - 60 Hz	100 - 240 V, 50 - 60 Hz	100 - 127/208 - 240 V, 50 - 60 Hz
<b>Weight (kg/lb)</b>	10.8/23.8	13.8/30.4	19/42	10.6/23.4	13.3/29.3
<b>Dimensions</b>	2 RU x 19" x 460 mm	2 RU x 19" x 465 mm	2 RU x 19" x 530 mm	2 RU x 19" x 435 mm	2 RU x 19" x 465 mm
<b>Remote</b>	OCA via Ethernet/CAN	OCA/AES70 via Ethernet	OCA via Ethernet/CAN	OCA via Ethernet/CAN	OCA/AES70 via Ethernet
<b>Airflow</b>					

# The controller setups and operation with d&b amplifiers

# The A-Series frequency responses

## CUT mode

Set to CUT, the cabinet low frequency level is reduced and is configured for use with d&b actively driven subwoofers.

## HFA mode

In HFA mode (High Frequency Attenuation), the HF response is rolled off. The HFA provides a natural, balanced frequency response when a unit is placed close to listeners in near field or delay use. HFA begins gradually at 1 kHz, dropping by approximately 3 dB at 10 kHz. This roll off mimics the decline in frequency response experienced when listening to a system from a distance in a typically reverberant room or auditorium.

## CPL function

The CPL (Coupling) function compensates for coupling effects between the cabinet and close boundary surfaces. CPL begins gradually around 1 kHz, with the maximum attenuation below 400 Hz. To achieve a balanced frequency response, the CPL function can be set to dB attenuation values between 0 and -9.

Positive CPL values create an adjustable low frequency boost (0 to +5 dB) at around 65 Hz and can be set when the system is used in full range mode without subwoofers.

## 100 Hz mode

The 100 Hz mode limits the upper operating frequency of the subwoofer to 100 Hz<sup>1</sup>, complementing top cabinets in full range mode.

## HFC mode

Selecting the HFC (High Frequency Compensation) mode compensates for loss of high frequency energy due to absorption in air when loudspeakers are used to cover far field listening positions. HFC has two settings which should be used selectively, HFC1 for cabinets covering distances larger than HFC1: 15 m (49 ft) and HFC2 for those covering distances larger than HFC2: 25 m (82 ft)

## Midrange directivity control

The MDC (Midrange directivity control) function compensates for constriction and unevenness within the 200 Hz to 2 kHz frequency range in arrays of three or four loudspeakers. MDC uses two setups: 'In' for inner cabinets and 'Out' for outer cabinets. MDC provides even distribution of the lower-mid frequency range, matching the high frequency dispersion set through typical array configurations.

## Recommended amplifiers for mobile applications

	AL60	AL90	V-GSUB
<b>D20</b>	x	x	
<b>D40</b>	x	x	
<b>D80</b>	x	x	x

## Recommended amplifiers for installation applications

	ALi60	ALi90	Vi-GSUB
<b>30D</b>	x	x	x
<b>40D</b>	x	x	x
<b>D80</b>	x	x	x

## Maximum loudspeakers per amplifier channel

AL60/ALi60	AL90/ALi90	V-GSUB/Vi-GSUB
2 <sup>2</sup>	2 <sup>2</sup>	2
1 <sup>3</sup>	1 <sup>3</sup>	

## Available controller settings

	AL60/ALi60	AL90/ALi90	V-GSUB/ Vi-GSUB
<b>In</b>	x	x	
<b>Out</b>	x	x	
<b>PS</b>	x	x	
<b>AP</b>	x	x	
<b>CUT</b>	x	x	
<b>HFA</b>	x	x	
<b>CPL</b>	x	x	
<b>100 Hz</b>			x
<b>HFC</b>	x	x	

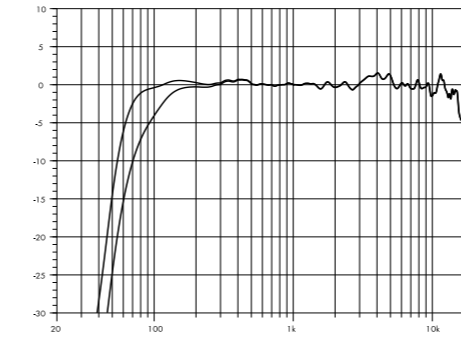

AL60/ALi60 standard and CUT (single cabinet)

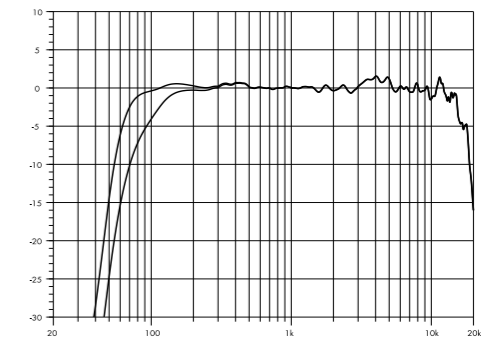

AL90/ALi90 standard and CUT (single cabinet)

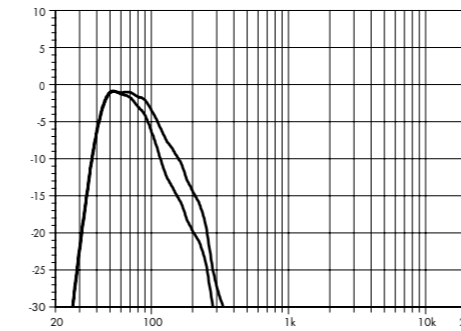

V-GSUB/Vi-GSUB standard and 100 Hz

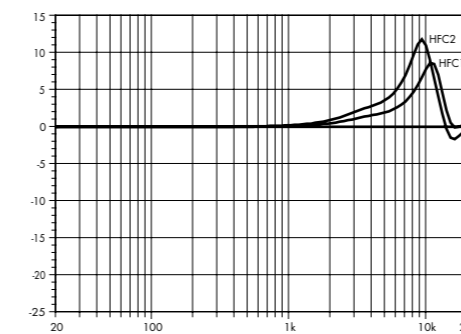

Correction of HFC\*  
\*schematic diagram

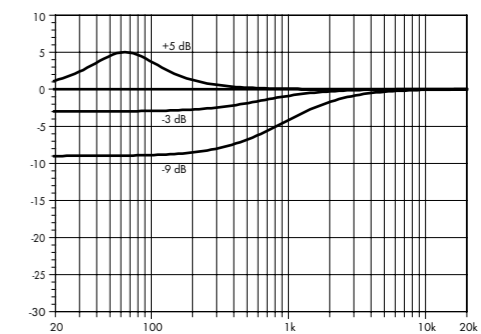

Frequency response correction of the CPL function\*  
\*schematic diagram

<sup>1</sup> For V-GSUB / Vi-GSUB upper frequency = 95 Hz  
<sup>2</sup> In PS (Point Source) or MDC (Midrange Directivity Control) setups only  
<sup>3</sup> with ArrayProcessing

# The d&b amplifier output modes

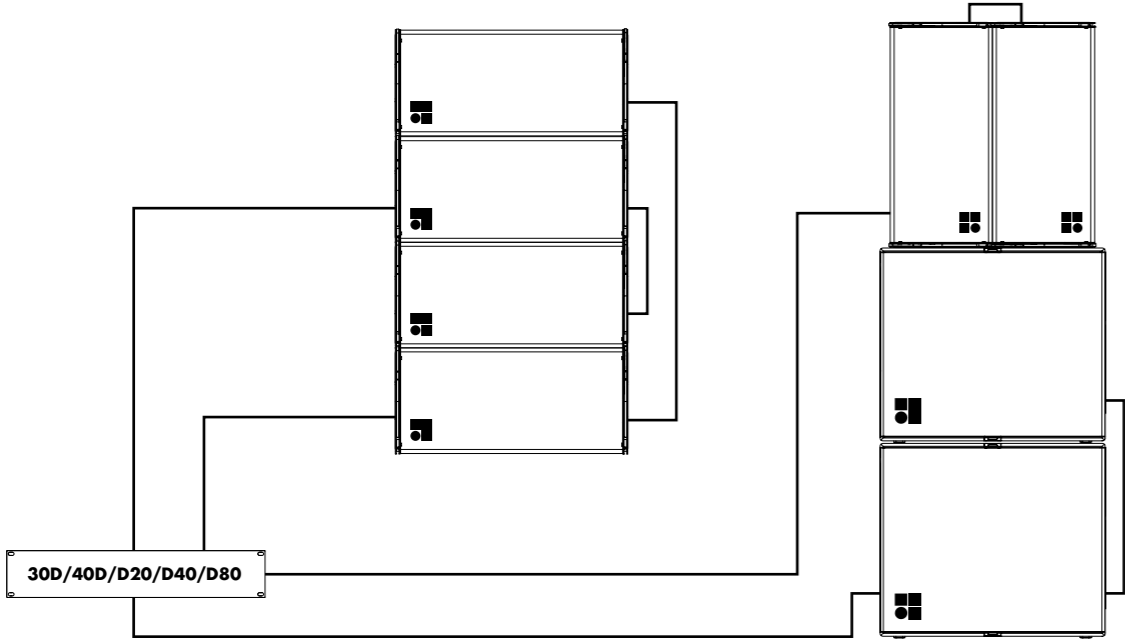

30D/40D/D20/D40/D80 amplifier in Dual Channel mode for AL60, AL90, ALi60, ALi90 as well as V-GSUB, Vi-GSUB

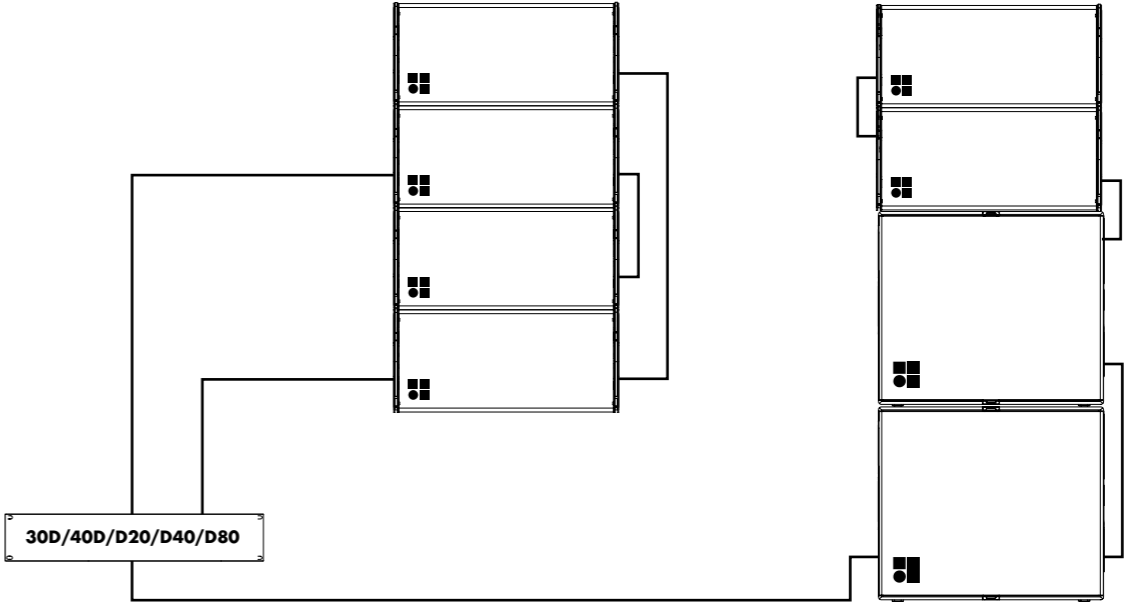

30D/40D/D20/D40/D80 amplifier in a mixed configuration of Dual Channel and Mix TOP/SUB mode for AL60, AL90, ALi60, ALi90 as well as V-GSUB, Vi-GSUB

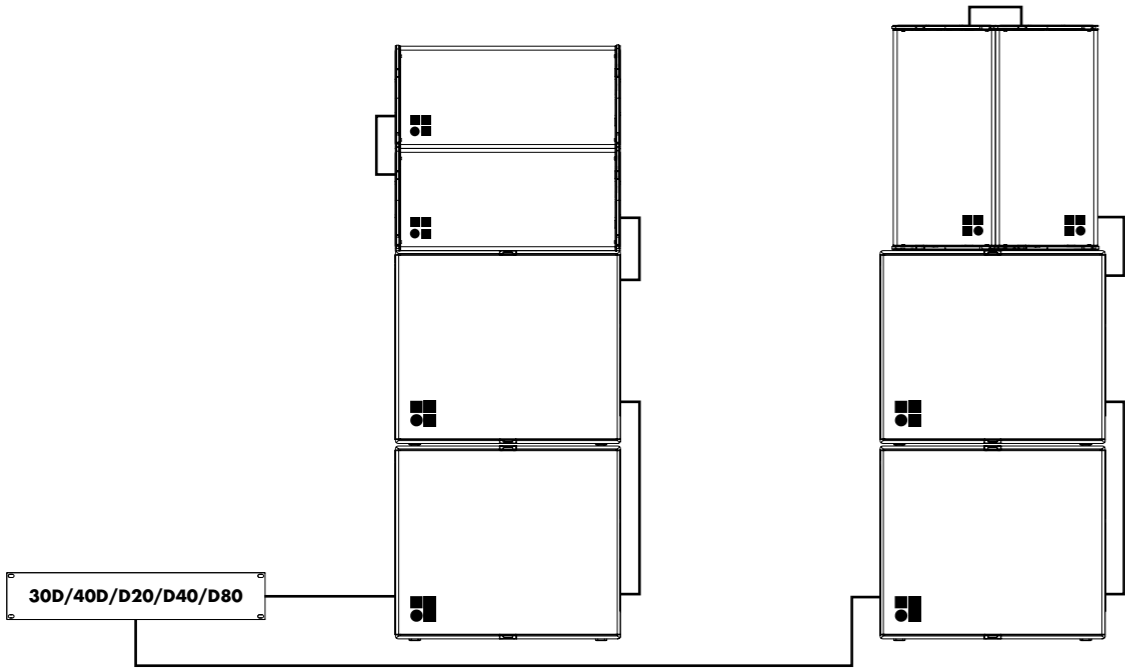

30D/40D/D20/D40/D80 amplifier in Mix Top/SUB mode for AL60, AL90, ALi60, ALi90 as well as V-GSUB, Vi-GSUB

# The DS10 and DS20 Audio network bridges

## The DS100 Signal Engine

### DS10 Audio network bridge

The DS10 Audio network bridge interfaces between Dante networks and AES3 digital audio signals, while also providing distribution of Ethernet control data. Positioned within the signal chain in front of the amplifiers, this 1 RU device expands the d&b system approach. Each unit can deliver up to sixteen Dante network channels via AES3 digital signal outputs. Additionally, four AES3 input channels provide access to the Dante audio network for applications such as a break-in from a Front of House console. The DS10 incorporates an integrated 5-port switch, offering a primary and redundant network for the Dante protocol, as well as advanced functions such as Multicast Filtering and VLAN modes. Using the DS10 Audio network bridge, audio signals and remote control data can be combined using a single Ethernet cable.



The DS10 Audio network bridge front view



The DS10 Audio network bridge rear view



The DS20 Audio network bridge front view



The DS20 Audio network bridge rear view



The DS100 Signal Engine front view



The DS100 Signal Engine rear view

### DS100 Signal Engine

The d&b DS100 Signal Engine is the platform underneath the Soundscape, based on a specialized rack mount 3 RU audio processor with Audinate Dante networking. It provides a 64 x 64 audio matrix with level and delay adjustments at all cross points. Additional software modules provide dynamic source positioning and emulated acoustics functions. The DS100 is a versatile tool for use within complex audio systems to route and distribute multiple audio channels to numerous amplifiers driving loudspeaker positions and zones, show relay and break out rooms. The networking capabilities with a Dante enabled processor are significant, particularly for busy, multi-room complexes. The DS100 completely integrates with the overall d&b system approach, including loudspeakers, amplifiers, rigging, transport and networking accessories and the DS10 Audio network bridge. The complete system is designed and optimized in the d&b ArrayCalc simulation software, and controlled via the d&b R1 Remote control software.

# The A-Series configuration examples

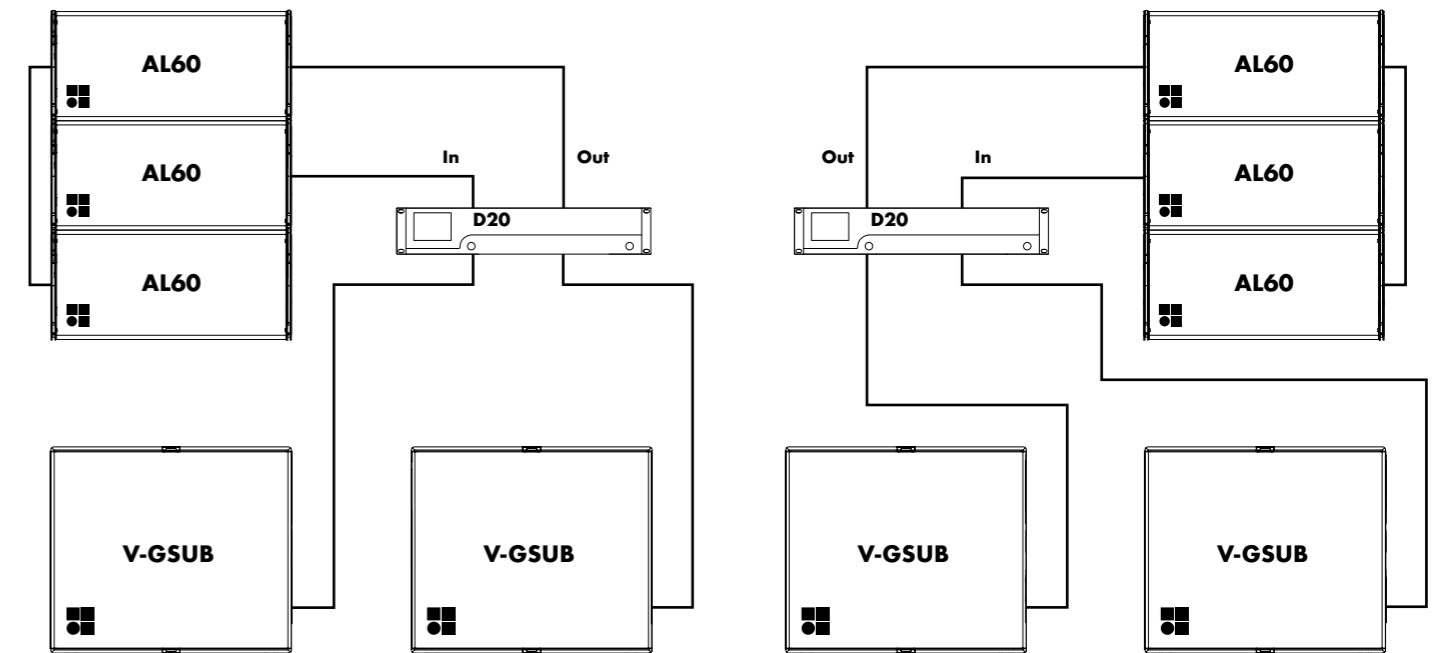

A-Series L/R configuration with vertical flow AL60 driven in Midrange directivity control (MDC) Setup: In/Out along with V-GSUB Sub array with D20 amplifiers

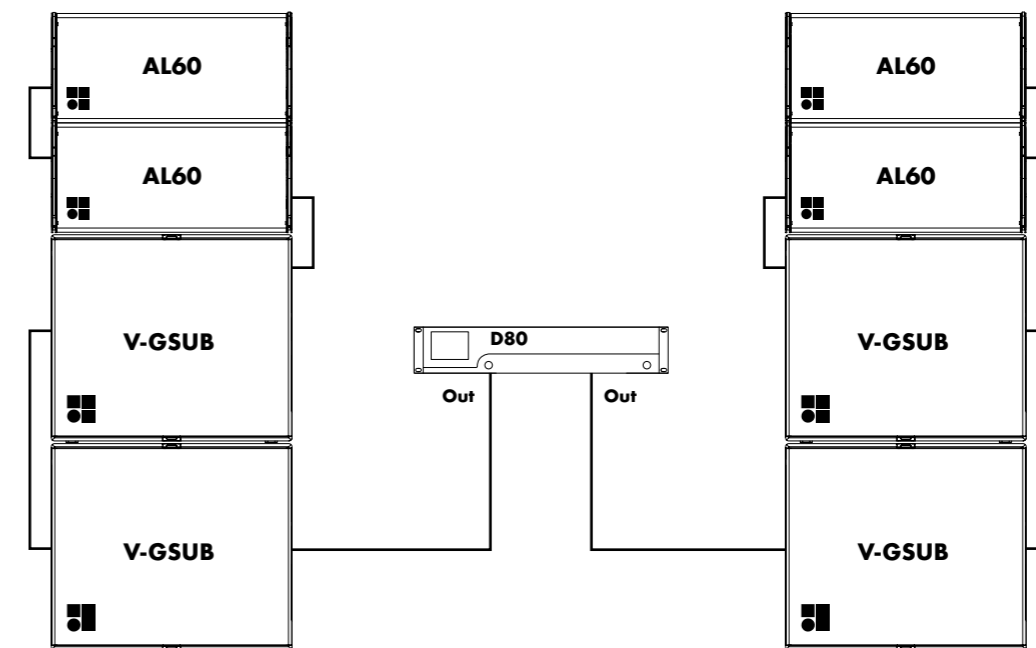

A-Series L/R DJ-Monitoring configuration with stacked AL60 on ground stacked V-GSUBs driven in Midrange directivity control (MDC) Setup: Out, with D80 amplifier in Mix TOP/SUB mode.

# The A-Series configuration examples

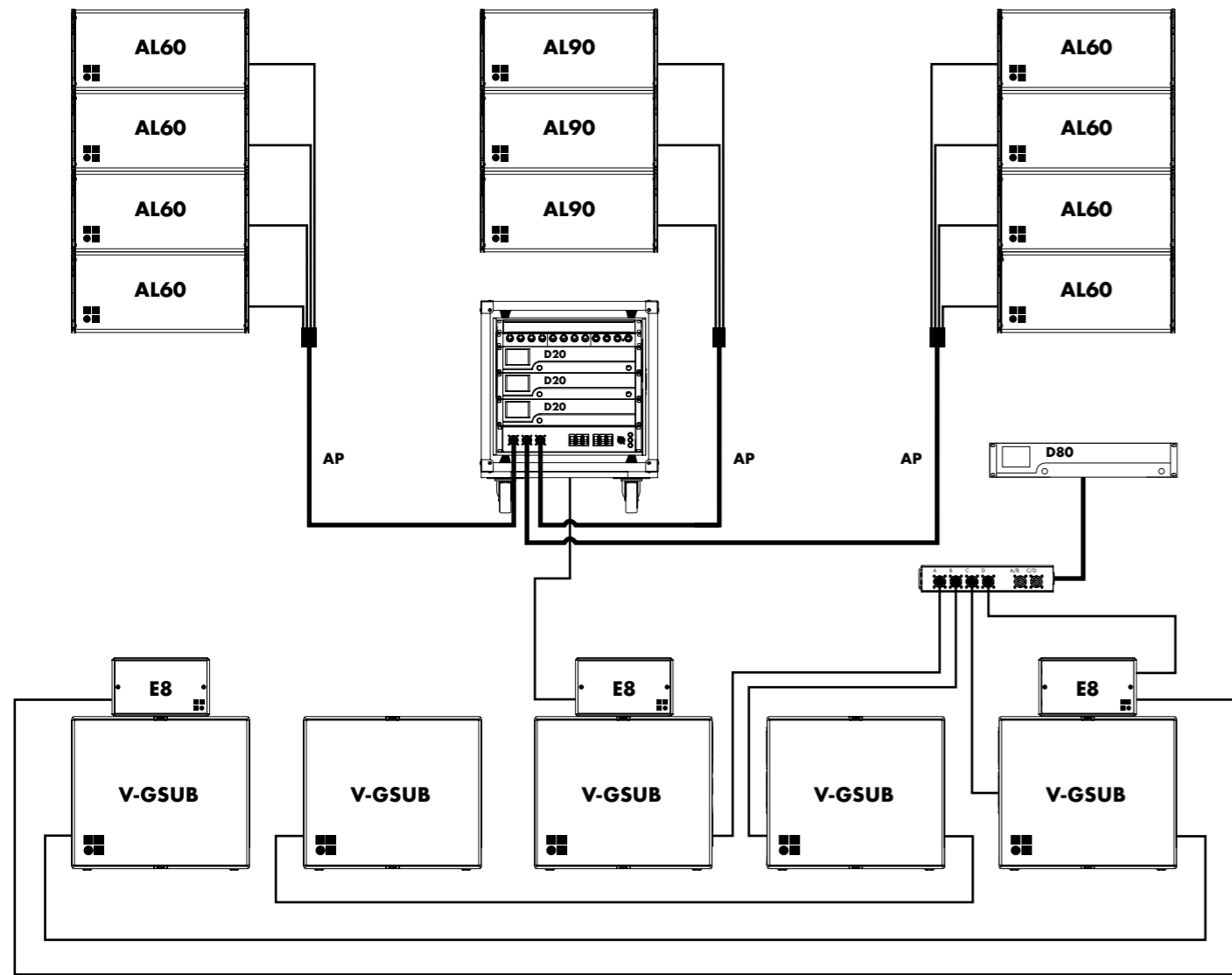

A-Series L/C/R configuration with vertical flown AL60/AL90 driven in Array Processing along with V-GSUB Sub array and E8 frontfills, with 3 x D20 Touring rack and D80 amplifier

# The A-Series configuration examples

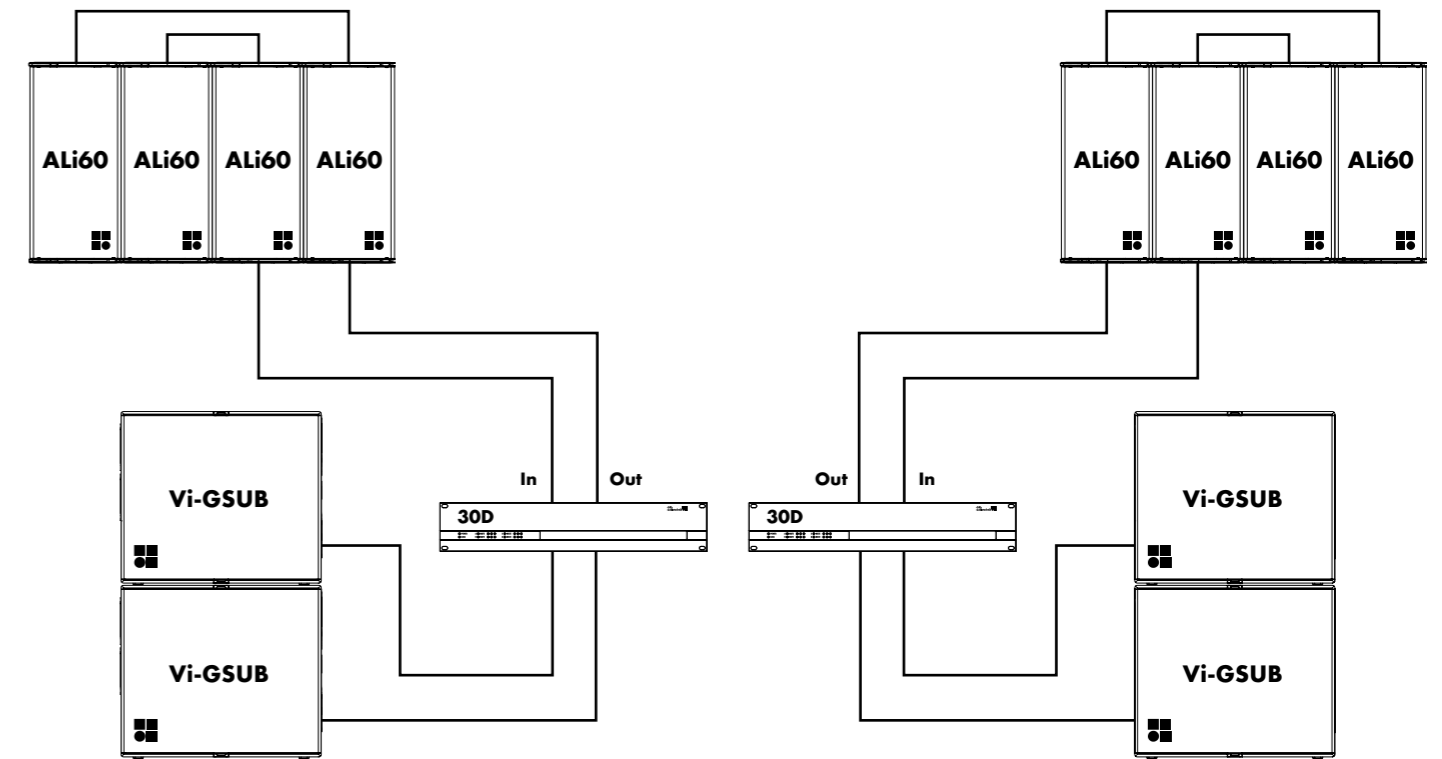

A-Series L/R configuration with horizontal flown ALi60 speakers driven in Midrange directivity control (MDC) Setup: In/Out along with ground stacked Vi-GSUB Subs, with 30D amplifiers



# The A-Series cables and adapters

## Amplifiers in Dual Channel mode

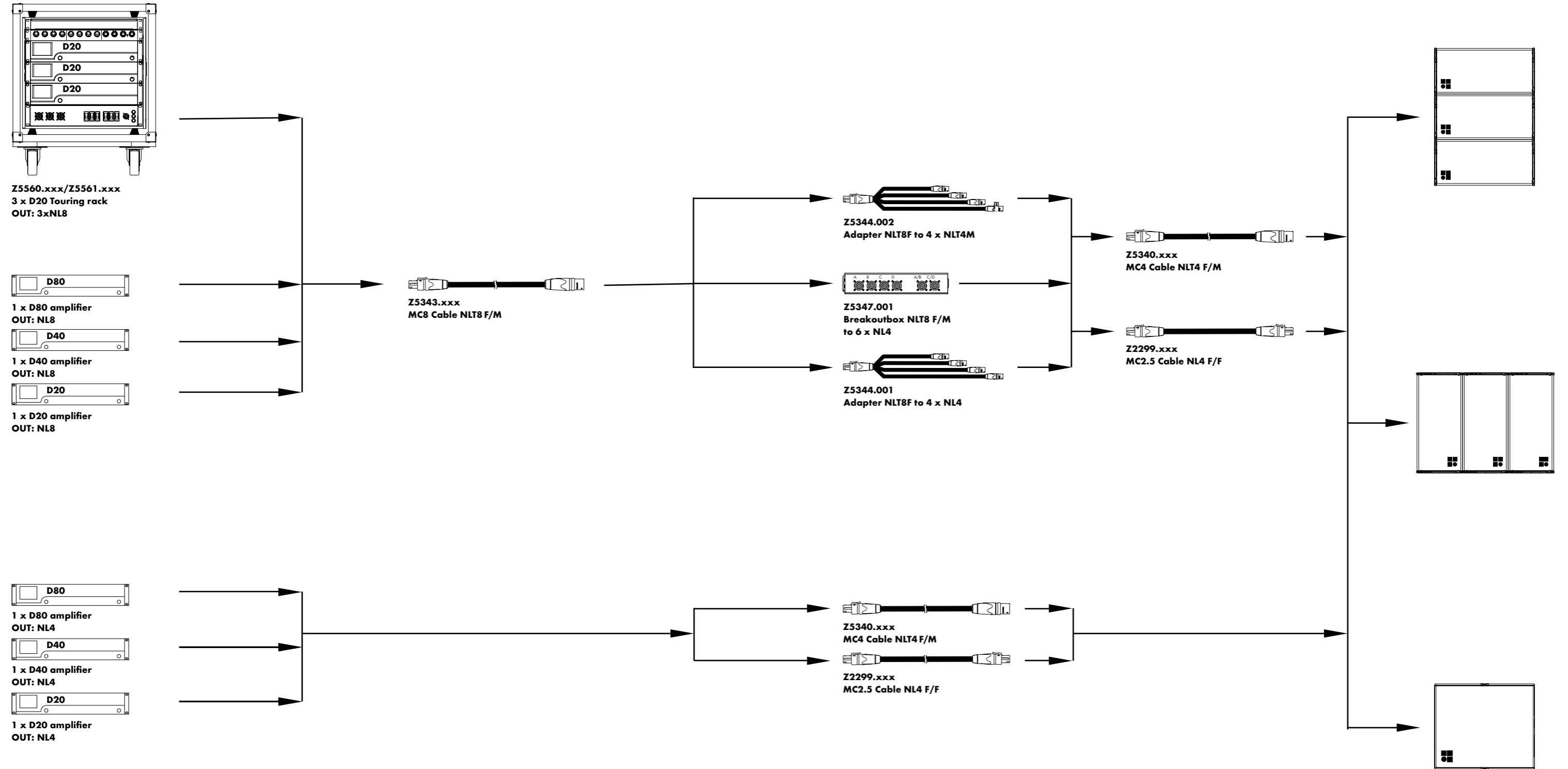

# The A-Series product overview

<b>Loudspeakers</b>	Z0730.xxx	<b>AL60 Loudspeaker</b> <sup>1</sup>	<b>Amplifiers</b>	Z2770.xxx	<b>30D Amplifier</b> <sup>6</sup>
	Z0731.xxx	<b>AL90 Loudspeaker</b> <sup>1</sup>		Z2830.xxx	<b>40D Amplifier</b> <sup>6</sup>
	Z0732.xxx	<b>ALi60 Loudspeaker</b> <sup>2</sup>		Z2750.xxx	<b>D20 Amplifier</b> <sup>5</sup>
	Z0733.xxx	<b>ALi90 Loudspeaker</b> <sup>2</sup>		Z2850.xxx	<b>D40 Amplifier</b> <sup>5</sup>
	Z0519.xxx	<b>V-GSUB</b> <sup>1</sup>		Z2710.xxx	<b>D80 Amplifier</b> <sup>5</sup>
Z0520.xxx	<b>Vi-GSUB</b> <sup>2</sup>				
<b>Loudspeaker connector options</b> <sup>4</sup>	Zxxxx.001	<b>NL4</b> connector <sup>3</sup>	<b>Amplifier rack assemblies</b>	Z5560.xxx	<b>3 x D20 Touring rack</b> <sup>7</sup>
	Zxxxx.002	<b>NLT4 F/M</b> connector <sup>3</sup>		Z5561.xxx	<b>3 x D20 Touring rack</b> (includes DS10) <sup>7</sup>
	Z0732.xxx	<b>ALi60 Loudspeaker Phoenix</b> socket		Z5570.xxx	<b>3 x D80 Touring rack</b> <sup>7</sup>
	Z0733.xxx	<b>ALi90 Loudspeaker Phoenix</b> socket		Z5571.xxx	<b>3 x D80 Touring rack</b> (includes DS10) <sup>7</sup>
<b>Loudspeaker cases</b>	E7927.000	<b>Touring case 2 x AL60/90</b>	<b>Amplifier racks</b>	E7480.000	<b>D20 Touring rack 2 RU, 19"</b> SD, shock mounted, handles <sup>7</sup>
		E7468.000		<b>D80 Touring rack 2 RU, 19"</b> SD, shock mounted, handles <sup>7</sup>	
		E7483.000		<b>DS100 Touring rack 3 RU, 19"</b> SD, shock mounted, handles <sup>7</sup>	
<b>Accessories</b>	Z5453.000	<b>AL Hoist connector chain</b>	<b>Cables</b>	Z5339.000	<b>Multichannel extension cable</b>
	Z5454.000	<b>AL Safety chain</b>		Z5343.xxx	<b>MC8 Cable NLT8 F/M</b>
	Z5455.000	<b>AL Flying frame</b> <sup>1</sup> (supplied with Z5454 AL Safety chain)		Z5344.002	<b>Adapter NLT8F to 4 x NLT4M</b>
	Z5456.000	<b>AL Flying adapter</b> <sup>1</sup>		Z5344.001	<b>Adapter NLT8F to 4 x NL4</b>
	Z5457.000	<b>AL Mounting bracket SVS</b>		Z5347.001	<b>Breakoutbox NLT8 F/M to 6 x NL4</b>
	Z5458.000	<b>AL Base plate</b> <sup>1</sup>		Z5340.xxx	<b>MC4 Cable NLT4 F/M</b>
	Z5459.000	<b>ALi Mounting frame top</b> <sup>1</sup>		Z2299.xxx	<b>MC2.5 Cable NL4 F/F</b>
	Z5460.000	<b>AL Stand adapter</b> <sup>1</sup>			
Z5461.000	<b>AL V-SUB adapter</b> <sup>1</sup>				
<b>Remote network</b>	Z6126.000	<b>R90 Touchscreen remote control</b>			
<b>Processing and distribution</b>	Z4010.000	<b>DS10 Audio network bridge</b>			
	Z4011.000	<b>DS20 Audio network bridge</b>			
	Z4100.000	<b>DS100 Signal Engine</b>			

<sup>1</sup> SC on request

<sup>2</sup> WR, SWR and SVS on request

<sup>3</sup> For AL and V-GSUB

<sup>4</sup> Custom solution loudspeakers have Faston type connectors

<sup>5</sup> The complete list of mobile amplifier versions is available in the d&b D Amplifier and Software brochure

<sup>6</sup> The complete list of installation amplifier versions is available in the d&b xD Installation Amplifier and Software brochure

<sup>7</sup> Further information is available in the d&b D Amplifier and Software brochure

