

# KSL

SL-Series

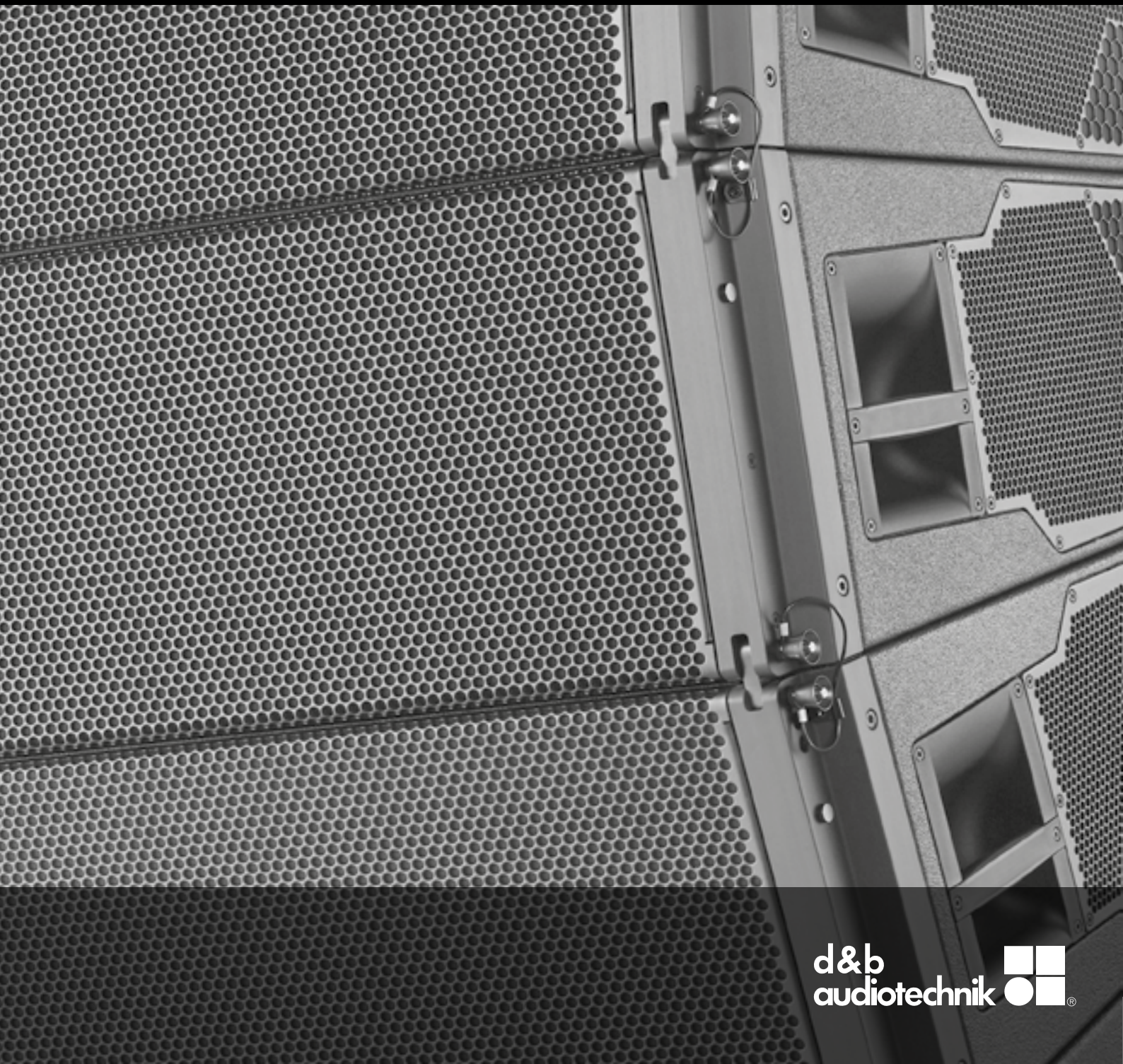

# Contents



<b>The d&amp;b System reality</b> .....	4
<b>The SL-Series</b> .....	6
<b>The KSL System</b> .....	8
<b>The KSL8 and KSL12 loudspeakers</b> .....	10
<b>The KSL-SUB and KSL-GSUB</b> .....	11
<b>The SL-SUB and SL-GSUB</b> .....	12
<b>The SL-Series rigging modes</b> .....	13
<b>The KSL rigging system</b> .....	14
<b>The KSL rigging examples</b> .....	15
<b>The KSL Touring carts</b> .....	16
<b>The KSL Touring carts examples</b> .....	17
<b>The d&amp;b ArrayCalc simulation software</b> .....	18
<b>The d&amp;b NoizCalc immission modelling software</b> .....	20
<b>The d&amp;b R1 Remote control software</b> .....	21
<b>The DS10 and DS20 Audio network bridges</b> .....	22
<b>The DS100 Signal Engine</b> .....	22
<b>The D40 and D80 amplifiers</b> .....	23
<b>The D40 and D80 Touring rack assemblies</b> .....	24
<b>The SL-Series system package</b> .....	25
<b>The controller setups and operation with D40 and D80 amplifier</b> .....	26
<b>The KSL System frequency responses</b> .....	27
<b>The KSL System configuration examples</b> .....	28
<b>The KSL System cables and adapters MC8/MC24</b> .....	32
<b>The KSL System product overview</b> .....	34

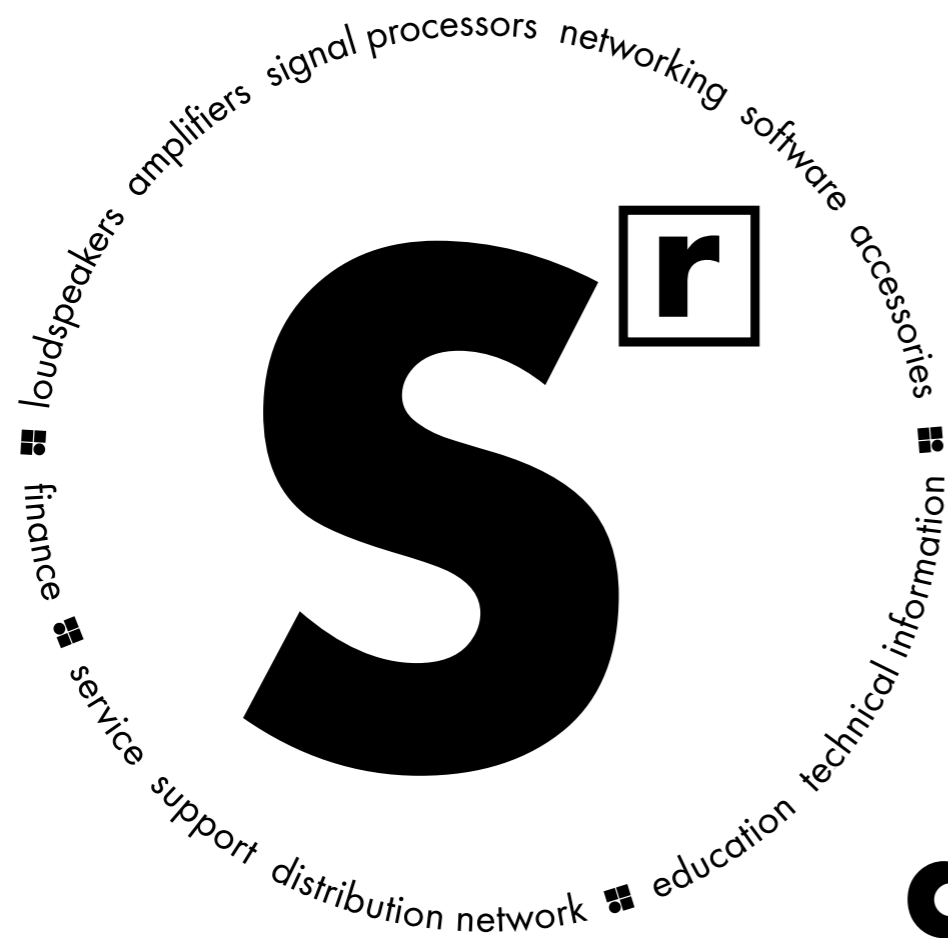

# d&b System reality

As the name implies a d&b audiotechnik system is not just a loudspeaker. Nor is it merely a sum of the components: loudspeakers, amplifiers, signal processors, networking, software and accessories. Right from the outset the d&b audiotechnik approach was to build integrated sound reinforcement systems

that actually are more than the combination of parts: an entirety where each fits all. Every element is tightly specified, precisely aligned and carefully matched to achieve maximum efficiency. For ease of use, all the user-definable parameters are incorporated, allowing the possibility of adjustment, either

directly, via remote control surfaces, or integrated within wider networks. Neutral sound characteristics leave the user all the freedom needed to realize whatever the brief. At the same time d&b offers finance, service and support, a knowledgeable distribution network, education and training as well as technical

information, so the same optimal acoustic result is achieved consistently by every system anywhere, at any time. In reality: the d&b System reality.

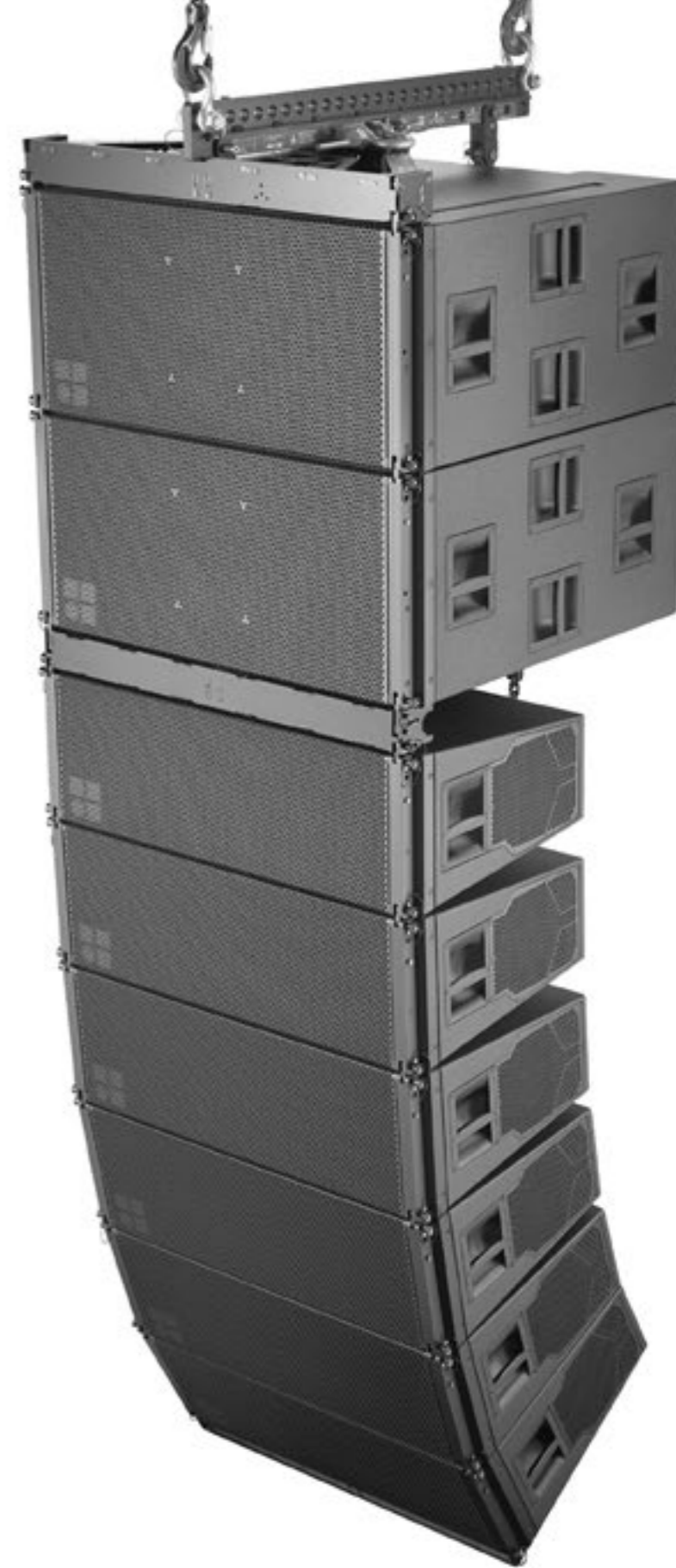

The SL-Series is a family of audio systems hailing from applied evolution; a development in more than one dimension delivering unprecedented directivity control and headroom over the entire audio spectrum. This couples with significant low frequency extension, comprehensive rigging, cabling and transportation solutions, all optimized for the highest speed

of deployment. The precise broadband directivity control curtails energy radiating to the rear of the systems right down to the lowest frequencies. This reduces the level radiating back to the stage, making more comfortable performance environments and diminishing lower frequency spill on open mics. When indoors, the accuracy of directivity control

significantly decreases stimulation of the reverberant field, while outdoors it keeps the energy focussed on the audience to substantially reduce any unwanted immissions. The KSL System, and its larger sibling the GSL System, are complete packages specifically designed to accurately deliver messages across all performance styles and musical genres over a wide variety

of applications in theatres, concert halls, arenas, stadiums as well as festivals, whether mobile or installed. The SL-Series combines unparalleled audio performance with maximum efficiency, neatly aligned to the system design, deployment, optimization and control capabilities of the tried and tested d&b Workflow.

# The KSL System

The **KSL System** is a part of the holistic d&b approach addressing the broadest range of applications where high quality sound reinforcement and reproduction are a prerequisite. The resulting systems are based on many years of applied evolution, where a clear understanding of the tasks and requirements has been coupled with advances in available technology and streamlined to achieve optimal results. The component parts described here combine to form systems, all the elements fitting together within the d&b Workflow to deliver ease of use, predictability of results, flexibility and speed of deployment.

The **KSL8** and **KSL12** line array modules are specifically designed for medium to large scale sound reinforcement. Sharing the same vertical directivity, size, footprint, weight, rigging and driver complement, up to twenty-four KSL loudspeakers can be flown in vertical columns. The 2-Way active design combines ingenious cabinet geometry with forward and side firing low frequency drivers, these couple towards the front, cancel towards the rear and increase low frequency headroom. The driver compliment is completed by a hornloaded mid range and two high frequency drivers mounted to a waveshaping device. The 80° horizontal directivity pattern of the KSL8 is seamlessly maintained down to the lowest frequencies the loudspeaker produces, while the high output capability can cover a distance range of over 100 m (330 ft), depending on the climatic conditions. The KSL12 has a wider horizontal dispersion pattern of 120° which is also maintained over the entire operating range.

The **KSL-SUB** is equipped with flying fittings, while the **KSL-GSUB** is for ground stacked use only. The bass-reflex design uses three 15" high excursion drivers, one of which radiates to the rear to produce cardioid subwoofer performance to avoid unwanted energy behind the system. The KSL-SUB and KSL-GSUB extend the bandwidth of a KSL System down to 36 Hz as well as increasing its headroom. The KSL-SUB shares the same width as the KSL loudspeakers enabling them to be easily flown in combination as a mixed array. Both subwoofers can be deployed in conventional left and right ground stacked setups as well as in distributed SUB arrays to achieve an even venue specific coverage pattern. The **SL-SUB** and **SL-GSUB** can also be used in combination with KSL loudspeakers.

The patented SL-Series rigging method and flying hardware enables rapid deployment of KSL8 and KSL12 arrays directly from the Touring cart in either compression or tension rigging modes. Designed to fit within standard shipping container and truck sizes, the KSL Touring cart accommodates four KSL8 or KSL12 loudspeakers, including flying frames and a transport cover. The KSL-SUB Touring cart can house up to three KSL-SUB or KSL-GSUBs with respective covers.

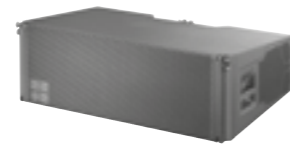

**KSL8 loudspeaker**

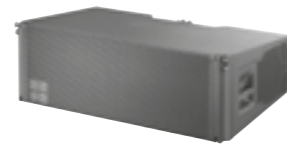

**KSL12 loudspeaker**



**KSL-SUB**



**KSL-GSUB**



**SL-SUB**



**SL-GSUB**

The d&b **ArrayCalc** simulation software allows the virtual optimization of line arrays, point source and column loudspeakers as well as subwoofers and their adjustment to venue conditions. The d&b **NoizCalc** immission modelling software uses international standards to model noise immission from d&b loudspeaker systems. NoizCalc takes data from ArrayCalc and calculates the sound propagation towards the far field. The complete system configuration simulated in ArrayCalc is assimilated by the d&b **R1** Remote control software into an intuitive graphical user interface to manage the system from anywhere in the venue.

A wide range of tools and data files are available to support the planning process using external tools. For enhanced acoustic simulations, all loudspeakers offer EASE files. BIM (Building Information Modelling) is supported with Revit files available for all loudspeakers and accessories, creating accurate project data and visualization. 2D and 3D CAD data is usable in most common planning tools. Venue data created by SketchUp can be imported to ArrayCalc using the d&b sketchup plug-in to facilitate system design.

d&b amplifiers are specifically designed for use with d&b loudspeakers, and are at the heart of the d&b system approach. These devices contain extensive Digital Signal Processing capabilities to provide comprehensive loudspeaker management and specific switchable filter functions to precisely target the system response for a wide variety of applications. The four channel **D40** and **D80** amplifiers are intended for mobile applications. The d&b amplifiers provide extensive user-definable equalization containing two 16-band equalizers with parametric, notch, shelving and asymmetric filters as well as delay capabilities of up to 10 seconds.

The d&b Audio network bridges interface between audio transport networks and AES3 digital audio signals while also providing distribution of Ethernet control data. The **DS10** supports Dante networks, while the **DS20** is used for the open standards-based Milan protocol.

The **DS100** Signal Engine is a specialized rack mount 3 RU audio processor with Dante networking. It provides a 64 x 64 audio matrix with level and delay adjustments at all cross points. Additional software modules provide source positioning and emulated acoustics functions.



**D40 amplifier**



**D80 amplifier**



**DS10 Audio network bridge**



**DS20 Audio network bridge**



**DS100 Signal Engine**

# The KSL8 and KSL12 loudspeakers

## KSL8 and KSL12 loudspeakers

The KSL8 and KSL12 line array modules produce, respectively, 80° and 120° constant directivity dispersion patterns in the horizontal plane over the entire operating bandwidth. Both cabinets share the same driver configuration, housing two 10" neodymium forward facing LF drivers and two side firing 8" neodymium LF drivers. A coaxial mid-high section contains an MF horn with a 8" driver and two 1.4" exit HF compression drivers with 3" voice coils mounted to a wave shaping device. The KSL-System flying hardware has a patented workflow with integrated tension and compression rigging modes, allowing splay angles from 0° to 10° in 1° increments. The loudspeakers are driven actively by two channels of an appropriate d&b amplifier. One channel powers the 10" LF drivers, the second channel powers all other components, which are passively crossed-over. The component geometry provides consistent, accurate horizontal dispersion control, which the front and side firing LF driver arrangement maintains seamlessly down to the lowest frequencies produced. Expanding flexibility for applications where ArrayProcessing is not required, the KSL8 and KSL12 include the option to link two cabinets in Arc/Line modes. The cabinets are constructed from marine plywood and have an impact and weather protected PCP (Polyurea Cabinet Protection) finish. The front and side panels incorporate rigid metal grills backed by an acoustically transparent and water repellent fabric. Each side panel incorporates a recessed handle, with additional handles provided at the rear.

### System data KSL8 • KSL12

Frequency response (-5 dB standard) ..... 54 Hz - 18 kHz  
 Frequency response (-5 dB CUT mode) ..... 75 Hz - 18 kHz  
 Max. sound pressure (1 m, free field) .....  
 with D40 ..... 145 dB<sup>1</sup> • 144 dB<sup>1</sup>  
 with D80 ..... 145 dB<sup>2</sup> • 144 dB<sup>2</sup>

### Loudspeaker data KSL8 • KSL12

Nominal impedance front LF ..... 8 ohms  
 Nominal impedance side LF/MF/HF ..... 8 ohms  
 Power handling capacity front LF (RMS/peak 10 ms) 450/1800 W  
 Power handling capacity side LF/MF/HF (RMS/peak 10 ms) .....  
 ..... 250/1000 W  
 Nominal dispersion angle (horizontal) ..... 80° • 120°  
 Splay angle settings ..... 0 - 10° (1° increment)  
 Components ..... 2 x 10" front LF driver  
 ..... 2 x 8" side LF driver  
 ..... 1 x 8" MF driver  
 ..... 2 x 1.4" exit compression driver with 3" voice coil  
 ..... Passive crossover network  
 Connections ..... 2 x NLT4 F/M  
 Weight ..... 58 kg (128 lb)

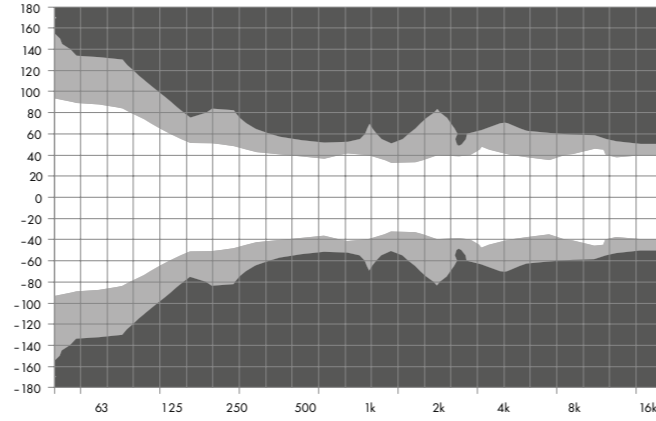

KSL8 horizontal dispersion characteristics<sup>2</sup>

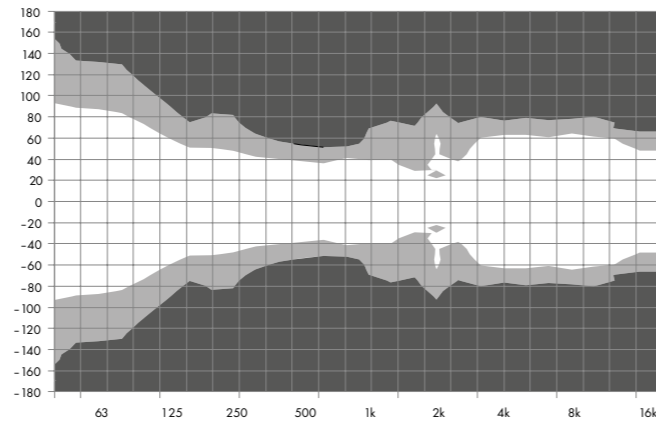

KSL12 horizontal dispersion characteristics<sup>3</sup>

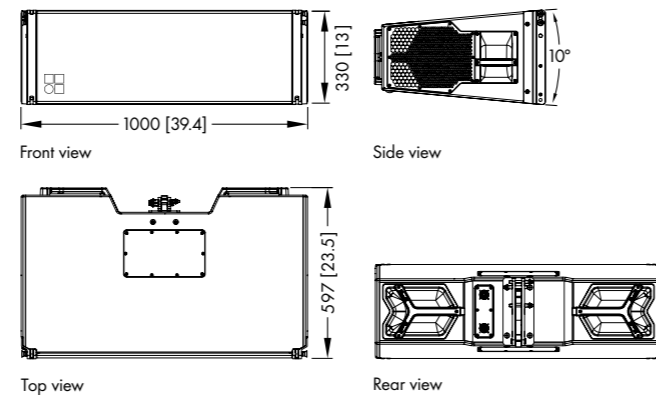

KSL8/KSL12 cabinet dimensions in mm [inch]

<sup>1</sup> SPLmax: Broadband signal IEC 60268, using 1 loudspeaker per channel  
<sup>2</sup> SPLmax: Broadband signal IEC 60268  
<sup>3</sup> Dispersion angle vs frequency plotted using lines of equal sound pressure (isobars) at -6 dB and -12 dB

# The KSL-SUB and KSL-GSUB

## KSL-SUB and KSL-GSUB

The KSL-SUB and KSL-GSUB are cardioid subwoofers designed to complement the KSL8 and KSL12 loudspeakers; they offer a frequency response extending from 36 Hz to 105 Hz. Both subwoofers are actively driven, 2-Way bass-reflex designs housing three long excursion 15" neodymium drivers. Two drivers face to the front while one radiates to the rear. The front and rear facing drivers operate in independent bass-reflex chambers and are driven from separate amplifier channels. Their cardioid dispersion pattern reduces unwanted energy behind the system, resulting in less excitation of the reverberant field for highly accurate low frequency reproduction.

The KSL-SUB rigging hardware allows columns of up to fourteen cabinets to be flown, while the KSL-GSUB is intended for ground stacked applications only. The KSL-SUB shares the same width as the KSL loudspeakers enabling them to be easily flown in combination as a mixed array by using the KSL-SUB Adapter frame. The KSL-SUB cabinet incorporates front rear rigging strands while the KSL-GSUB has no rigging components.

The cabinets are constructed from marine plywood with an impact and weather protected PCP (Polyurea Cabinet Protection) finish. The front and rear of the subwoofers are protected by a rigid metal grill backed by an acoustically transparent and water repellent fabric. Two runners extend from the front to the rear to protect the bottom panel. Two correspondingly shaped recesses are incorporated into the top panel which accept the runners and prevent cabinet movement when multiple subwoofers are stacked. Four recessed handles are incorporated into the subwoofers' side panels and four heavy duty wheels are mounted to their rear.

### System data KSL-SUB • KSL-GSUB

Frequency response (-5 dB standard) ..... 36 Hz - 105 Hz  
 Frequency response (-5 dB INFRA mode) ..... 33 Hz - 75 Hz  
 Max. sound pressure (1 m, free field) .....  
 with D40 ..... 139 dB<sup>1</sup>  
 with D80 ..... 139 dB<sup>1</sup>

### Loudspeaker data KSL-SUB • KSL-GSUB

Nominal impedance front/rear ..... 4/8 ohms  
 Power handling capacity front (RMS/peak 10 ms) ... 900/3500 W  
 Power handling capacity rear (RMS/peak 10 ms) ... 500/2000 W  
 Components ..... 3 x 15" driver  
 Connections ..... 1 x NLT4F  
 Weight ..... 82 kg (181 lb) • 78 kg (172 lb)

<sup>1</sup> SPLmax: Broadband signal IEC 60268

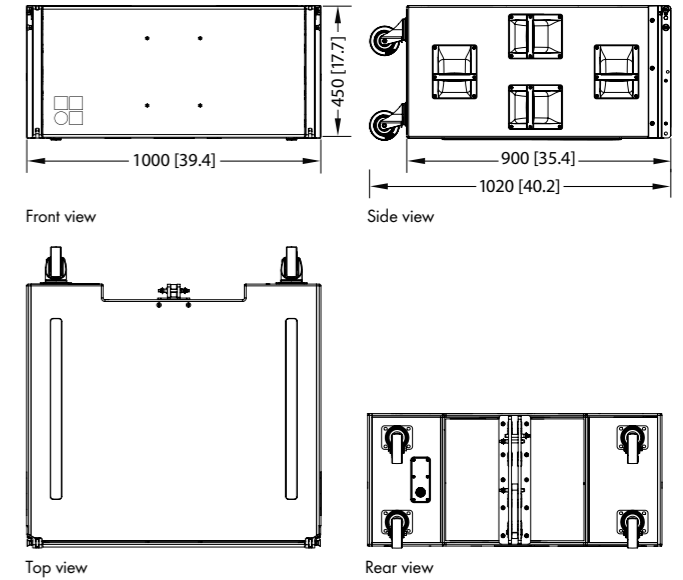

KSL-SUB/KSL-GSUB cabinet dimensions in mm [inch]

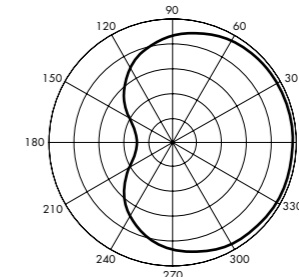

Cardioid polar pattern

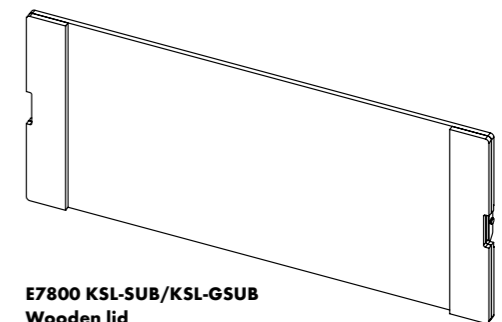

E7800 KSL-SUB/KSL-GSUB Wooden lid

# The SL-SUB and SL-GSUB

## SL-SUB and SL-GSUB

The SL-SUB and SL-GSUB are cardioid subwoofers to compliment the KSL8 and KSL12 loudspeakers. The SL-SUB rigging hardware allows columns of up to 14 cabinets to be flown while the SL-GSUB is intended for ground stacked applications only. Both subwoofers are actively driven, 2-way bass-reflex designs housing three long excursion 21" neodymium drivers. Two drivers face to the front while one radiates to the rear. The front and rear facing drivers operate in independent bass reflex chambers and are driven from separate amplifier channels. The cardioid dispersion pattern reduces unwanted energy behind the system, resulting in less excitation of the reverberant field to deliver highly accurate low frequency reproduction. The frequency response extends from 33 to 84 Hz/30 to 65 Hz. The SL-SUB cabinet incorporates front rear rigging strands while the SL-GSUB has no rigging components and is intended for ground stack purposes.

The cabinets are constructed from marine plywood with an impact and weather protected PCP (Polyurea Cabinet Protection) finish. The front and rear of the subwoofers are protected by rigid metal grills backed by an acoustically transparent and water repellent fabric. Two runners extend from the front to rear to protect the bottom panel. Two correspondingly shaped recesses are incorporated in the top panel accepting the runners and preventing cabinet movement when subwoofers are stacked. The side panels incorporate four recessed handles and four heavy duty wheels are mounted on the rear of the subwoofers.

## System data SL-SUB • SL-GSUB

Frequency response (-5 dB standard) ..... 33 Hz - 84 Hz  
 Frequency response (-5 dB INFRA mode) ..... 30 Hz - 65 Hz  
 Max. sound pressure (1 m, free field) .....  
 with D80 ..... 144 dB<sup>1</sup>

## Loudspeaker data SL-SUB • SL-GSUB

Nominal impedance front/rear ..... 3/6 ohms  
 Power handling capacity front (RMS/peak 10 ms).... 1000/4000  
 Power handling capacity rear (RMS/peak 10 ms).. 500/2000 W  
 Components ..... 3 x 21" driver  
 Connections ..... 1 x NLT4 F  
 Weight ..... 138 kg (304 lb) • 132 kg (291 lb)

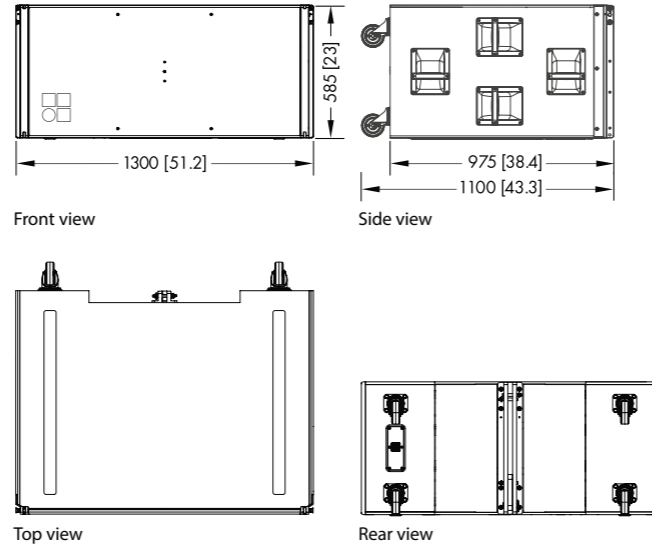

SL-SUB/SL-GSUB cabinet dimensions in mm [inch]

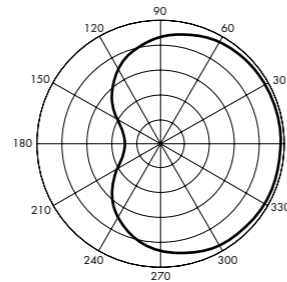

Cardioid polar pattern

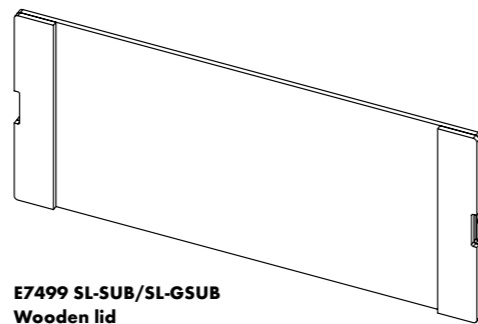

E7499 SL-SUB/SL-GSUB Wooden lid

# The SL-Series rigging modes

## Tension and compression modes

The KSL System rigging has been optimized to incorporate solutions for every eventuality. The patented flying hardware and method enables rapid deployment of KSL System arrays directly from the Touring cart in either compression or tension rigging modes. Tension mode uses the well-established d&b three-point rigging, while the compression mode needs a smaller footprint and is faster and safer for large arrays. Loudspeakers are flown as straight arrays, the d&b Z5724 Compression set curves the array to produce the coverage defined by the splay angle settings; a motorized chain hoist may also be used.<sup>1</sup>

Mounted directly on the KSL Flying frame, the d&b ArraySight laser inclinometer contains temperature and humidity sensors, this information is relayed to the R1 Remote control software using the OCA/AES70 protocol.

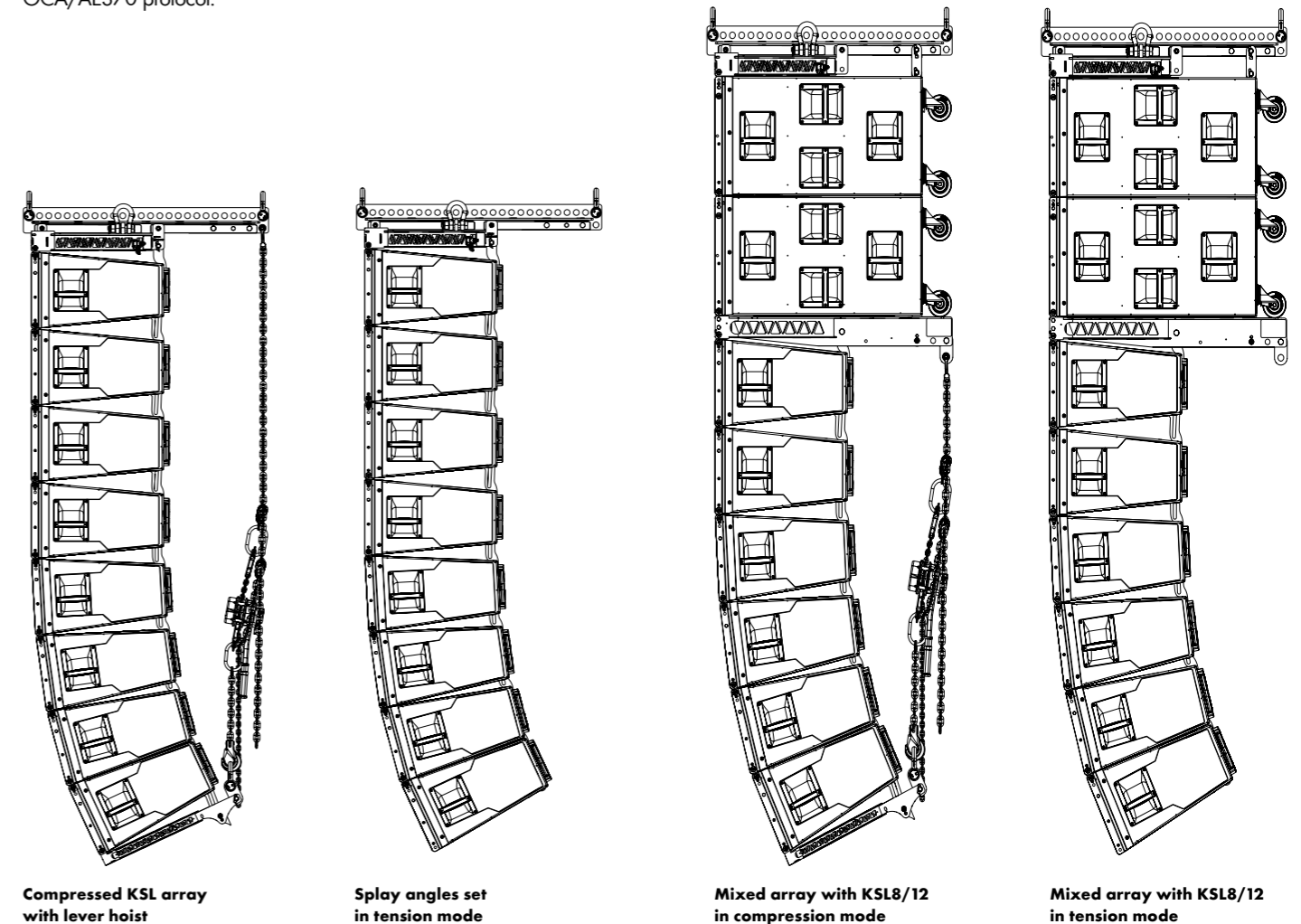

<sup>1</sup> The maximum permitted compression force is 1000 kg (1.0 t/10 kN). The motor hoist must be equipped with two independent brakes (according to the German D8 Plus standard)

# The KSL rigging system

# The KSL rigging examples

## Safety approval

d&b loudspeakers and accessories are designed for setup and use within situations requiring compliance with the provisions and directives of the DGUV regulation 17 (formerly BGV C1).

These rigging examples are for illustration only. For further information please refer to the TI 385 d&b Line array design as well as the SL-Series Rigging manual, both of which are available for download at [www.dbaudio.com](http://www.dbaudio.com).

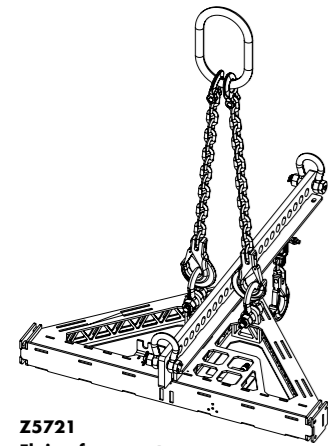

**Z5721**  
Flying frame set

### Flying frame set consists of:

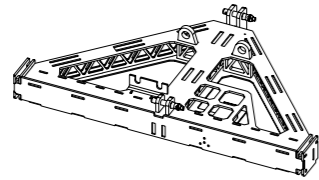

**Z5722**  
KSL Flying frame

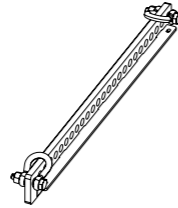

**Z5723**  
Load beam



**Z5705**  
Safety chain 4t



**Z5761**  
ArraySight sender unit

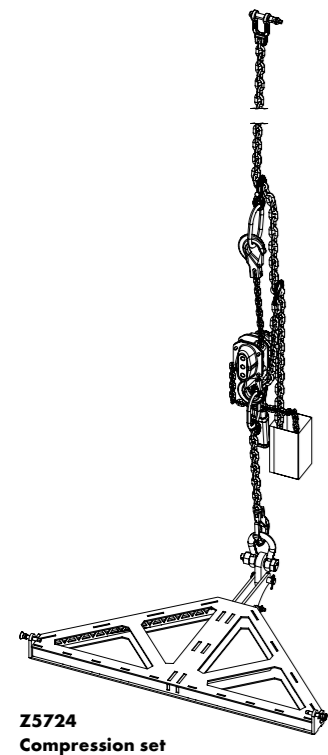

**Z5724**  
Compression set

### Compression set consists of:

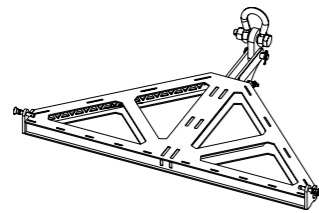

**Z5725**  
KSL Compression frame



**B2447.072**  
Lever hoist



**B2447.074**  
Compression frame master link



**B2447.073**  
Compression grab link



**Z5709**  
Compression chain 2.5t

### Single accessories:

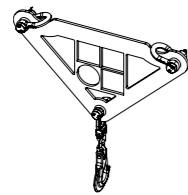

**Z5707**  
SL Aiming plate

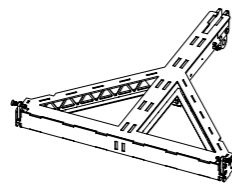

**Z5747**  
KSL-SUB Adapter frame

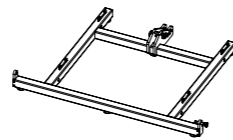

**Z5731**  
KSL Stacking frame



**Z5706**  
Hoist connector chain 4t



**Z5762**  
ArraySight meter unit

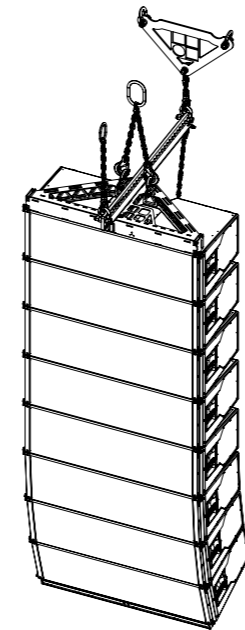

**KSL8/12 Line array 8-deep**  
Compression mode - Front

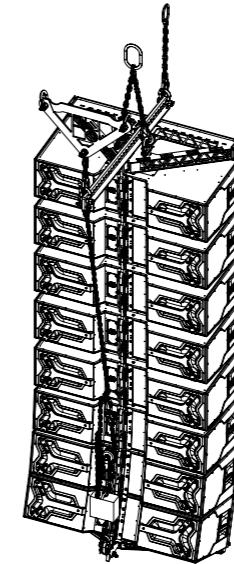

**KSL8/12 Line array 8-deep**  
Compression mode - Rear

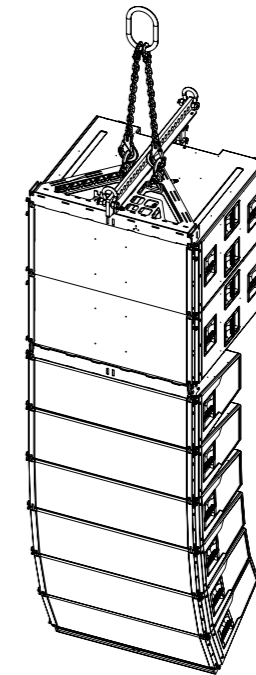

**KSL-SUB/ KSL8/12 Mixed array**  
Compression mode - Front

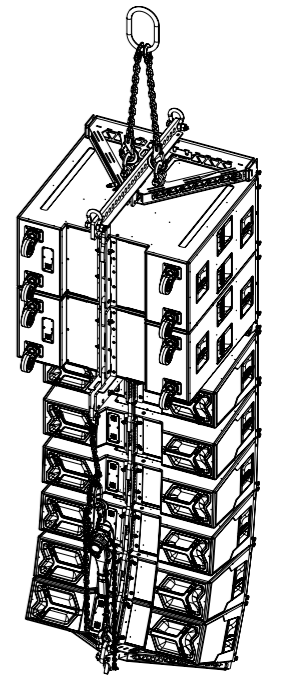

**KSL-SUB/ KSL8/12 Mixed array**  
Compression mode - Rear

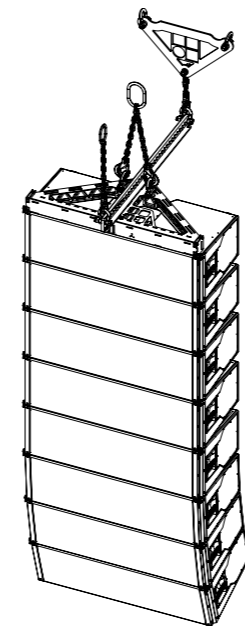

**KSL8/12 Line array 8-deep**  
Tension mode - Front

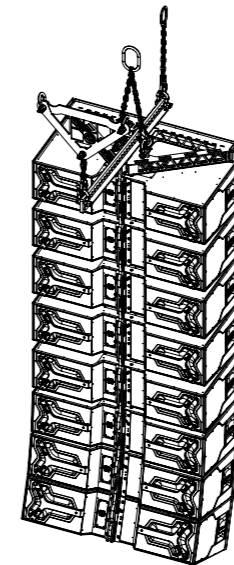

**KSL8/12 Line array 8-deep**  
Tension mode - Rear

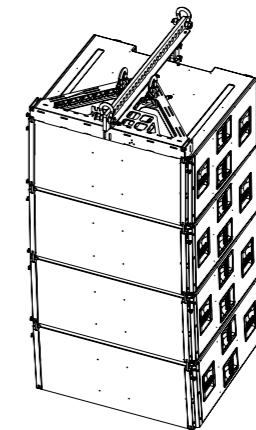

**KSL-SUB column 4-deep**  
2° splay Front

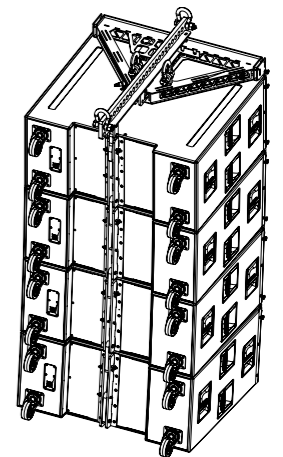

**KSL-SUB column 4-deep**  
2° splay - Rear



# The KSL Touring carts

# The KSL Touring carts examples

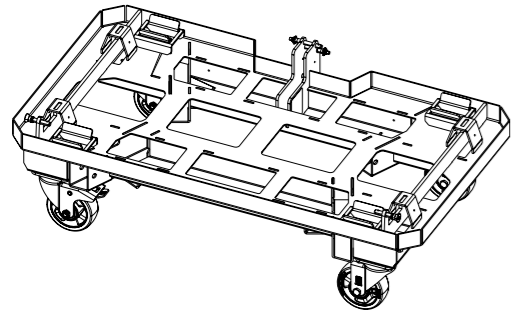

**E7802**  
Touring cart 4 x KSL8/KSL12

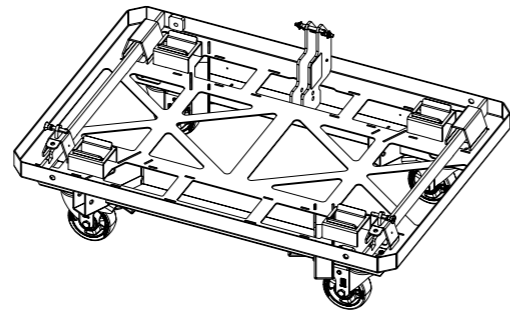

**E7495**  
Touring cart 4 x KSL8/KSL12 tension

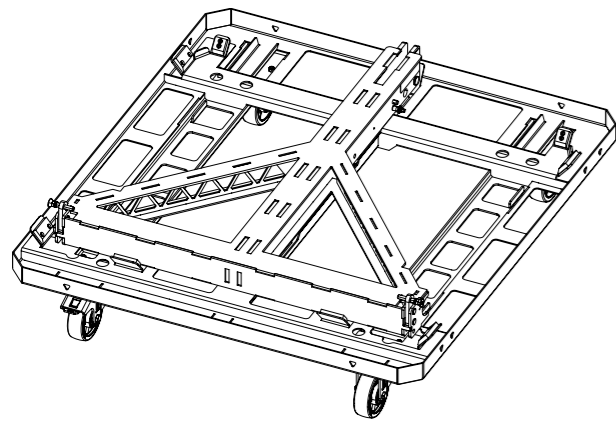

**E7804**  
Touring cart KSL-SUB/KSL-GSUB with KSL-SUB Adapter frame<sup>1</sup>

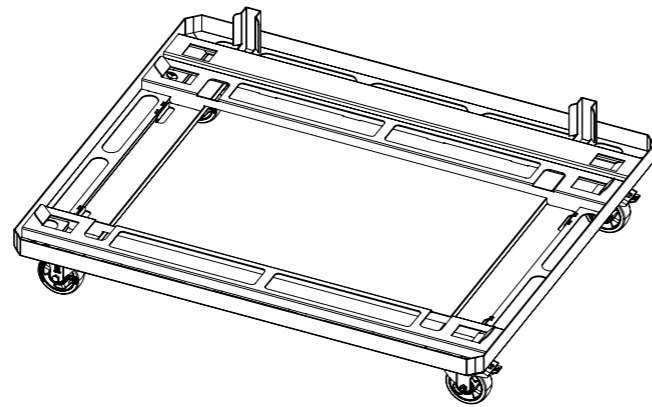

**E7492**  
Touring cart 5L-SUB/5L-GSUB

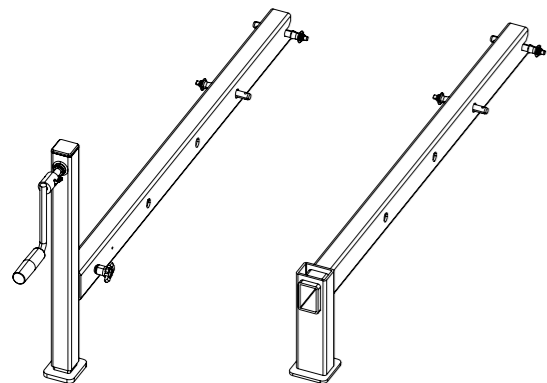

**E7494**  
SL Outriggers



**E7801**  
Touring case KSL compression

## Safety approval

d&b loudspeakers and accessories are designed for setup and use within situations requiring compliance with the provisions and directives of the DGUV regulation 17 (formerly BGV C1).

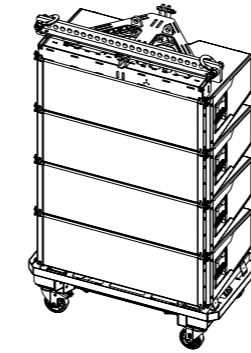

**E7802**  
4 x KSL8/KSL12 Touring cart Loaded in Compression mode with mounted vKSL Flying frame and KSL Load beam

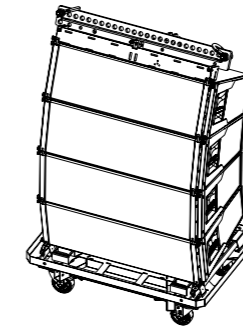

**E7495**  
4 x KSL8/KSL12 Touring cart Loaded in Tension mode with mounted KSL Flying frame and KSL Load beam

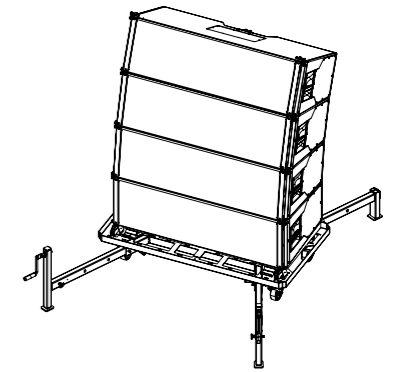

**KSL8/KSL12 Ground stack with E7495**  
Touring cart tension and E7494 Outriggers as Ground support

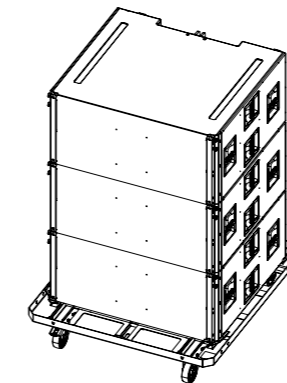

**E7804**  
KSL-SUB/KSL-GSUB Touring cart

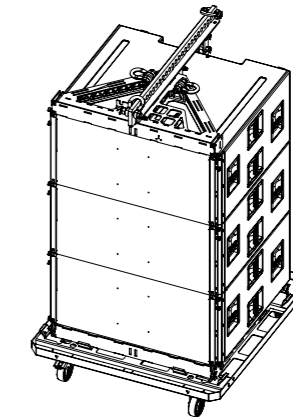
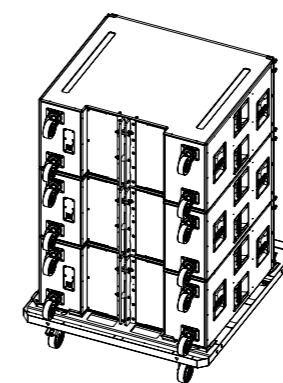

**KSL-SUB Touring cart**  
with mounted KSL-SUB Adapter frame and KSL Flying frame

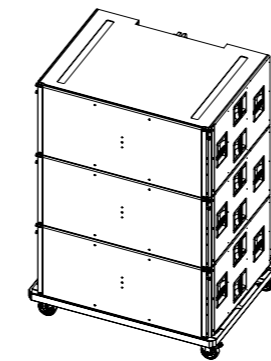

**E7492**  
SL-SUB/SL-GSUB Touring cart

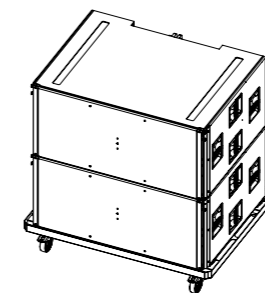

<sup>1</sup> KSL-SUB Adapter frame is not included in the Touring cart

# The d&b ArrayCalc simulation software

The d&b ArrayCalc simulation software is the prediction tool for d&b line arrays, column and point source loudspeakers as well as subwoofers. This is a comprehensive toolbox for all tasks associated with acoustic design, performance prediction, alignment, rigging and safety parameters. For safety reasons d&b line arrays must be designed using the d&b ArrayCalc simulation software. ArrayCalc is available as a native stand-alone application for both Microsoft Windows<sup>1</sup> (Win7 64-bit or later) and Mac OS X<sup>2</sup> (10.12 or later) operating systems. In combination with the d&b Remote Network, this can significantly reduce setup and tuning time in mobile applications and allows for precise simulations when planning installations. Listening planes can be defined in the venue tab, creating a three dimensional representation of any audience area in a given venue. This can also include balconies, side stalls, arenas, in the round scenarios or festivals. Special functions assist in obtaining accurate dimensions with laser distance finders and inclinometers.

## Simulation

Up to forty flown arrays or subwoofer columns can be defined in a project file as single hangs or in pairs. A selection of d&b point source loudspeakers can also be fully integrated as well as a ground stacked SUB array consisting of up to eighty positions. All can be freely positioned according to their intended application, for example as main hang, outfill, nearfill or delay. Position, orientation, aiming and coverage details are displayed. Level over distance is calculated for each source with high resolution in real time, for either band limited or broadband input signals. The comprehensive simulation precisely models the actual performance of the system, taking into account input level, all system configuration options (such as CUT, CPL, HFC or INFRA), limiter headroom and air absorption. Acoustic obstacles, such as video screens, can be added to a model. Acoustic shadowing, whether by these obstacles, or a balcony overhang, is taken into consideration. The load status of all array rigging components is calculated accurately and displayed to determine whether a given array is within the load tolerance. Subwoofer array design is assisted by coverage and polar plot prediction. A specialized algorithm allows the user to specify subwoofer positions and a coverage angle, which is then converted into appropriate delay settings that result in the desired dispersion. The alignment tab enables different sources to be time aligned to one another, as well as showing arrival times and Sound Pressure Levels at a definable reference point on one of the audience areas. For alignment of the flown system with the ground stacked SUB array, the phase response of both the SUB array and a flown source is calculated at a definable reference point.

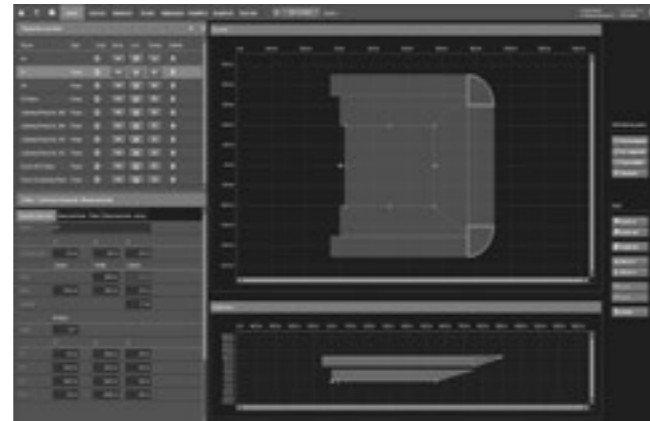

Venue

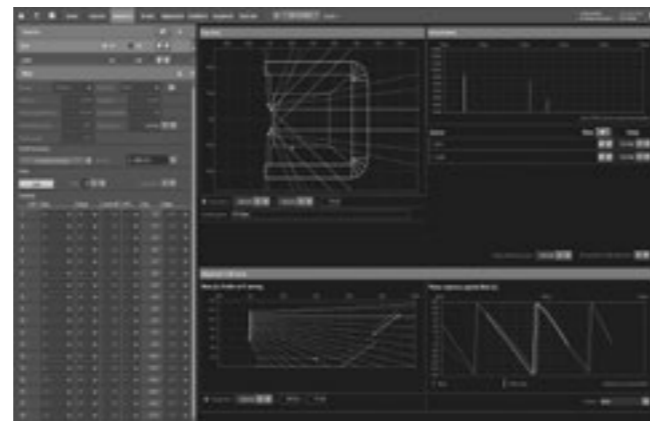

Alignment

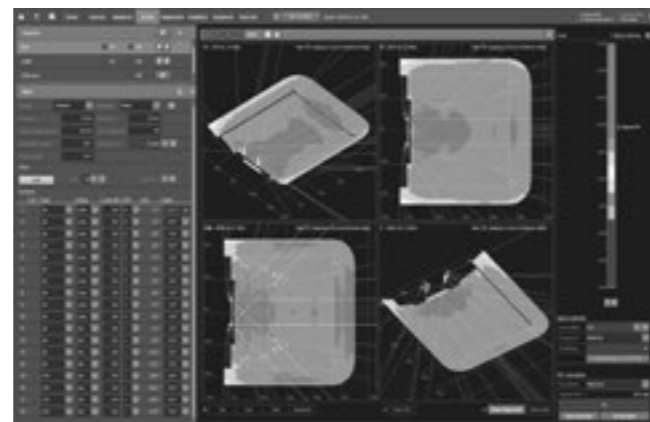

3D Plot quad

Both simulations reflect changes in delay time to the single sources in real time. The d&b ArrayCalc simulation software is available at [www.dbaudio.com](http://www.dbaudio.com).

## Prediction

The level distribution resulting from the interaction of all active sources can be mapped onto the audience areas in a three-dimensional view, which can also be zoomed, rotated and exported as a graphics file. EASE and DXF data export capabilities are also available. A rigging plot with all necessary coordinates, dimensions and weights of arrays is generated for export and printing and a parts list, detailing all components required. The d&b ArrayCalc Viewer app presents this key information for positioning and flying a d&b audiotechnik loudspeaker system on a mobile device. Once the system has been designed, calculated and optimized, all relevant project information can be shared via email, AirDrop, or downloaded onto any iOS or Android device.

## ArrayProcessing

The optional ArrayProcessing function applies powerful filter algorithms to optimize the tonal (spectral) and level (spatial) performance of a line array column over the audience area defined by its mechanical vertical coverage angle. Temperature and Humidity Control (THC) for ArrayProcessing introduces a workflow that permits a system to adapt to changing atmospheric conditions in real time via R1. Within the d&b ArrayCalc simulation software, spectral and level performance targets over the listening areas can be defined while specific level drops or offsets can be applied to certain areas, to assign reduced level zones. ArrayProcessing applies a combination of FIR and IIR filters to each individual cabinet in an array to achieve the targeted performance, with an additional latency of only 5.9 ms. This significantly improves the linearity of the response over distance as well as seamlessly correcting for air absorption. In addition, ArrayProcessing employs the same frequency response targets for all d&b line arrays, to ensure all systems share a common tonality. The resulting coverage is enhanced with spectral consistency and defined level distribution, achieving more linear dispersion and total system directivity to cover longer distances or steep listening areas effectively.

## R1 Remote Control Software

R1 uses the same project file created by ArrayCalc and generates an intuitive graphical user interface including complete details of the simulated system, loudspeakers, amplifiers, remote IDs, groups, ArrayProcessing data and all configuration information. This workflow removes the need to manually transfer data from one software program to the other.

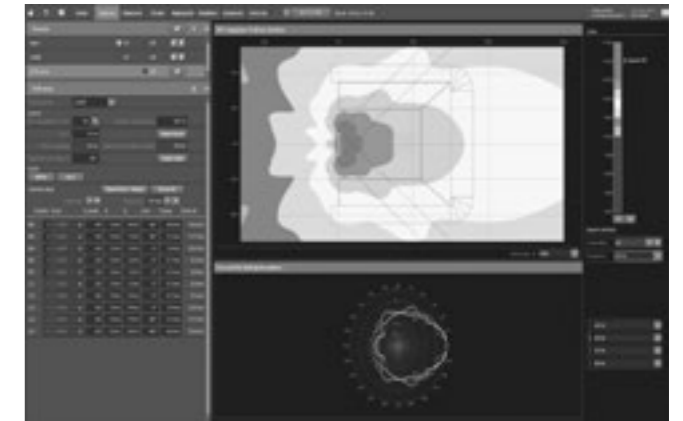

Sources, SUB array

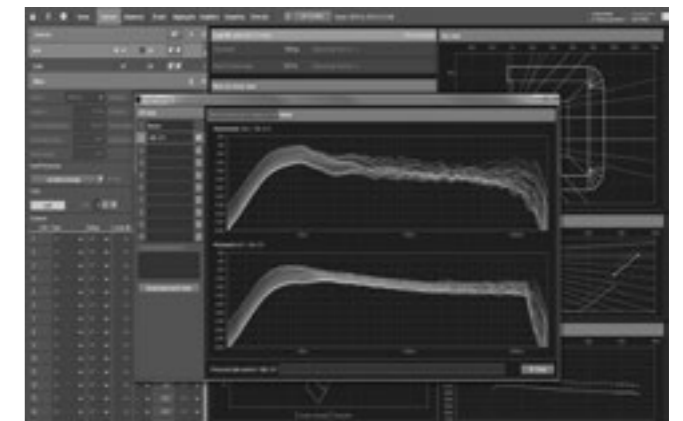

ArrayProcessing



Amplifiers

<sup>1</sup> Microsoft Windows is a registered trademark or trademark of Microsoft Corporation in the United States and/or other countries

<sup>2</sup> Mac OS X is a trademark of Apple Inc., registered in the U.S. and other countries

# The d&b NoizCalc immission modelling software

The d&b software uses international standards to model the far field noise immission from multiple complex and coherently emitting sources such as line arrays and subwoofer arrays. More and more, gaining permission and licenses to stage live open air events requires an official statement with a prediction of how noise could impact on the surrounding area. NoizCalc takes all complex loudspeaker data and a reference point from the d&b ArrayCalc simulation software and calculates the sound propagation and relative attenuation values towards the far field for a certain scenario with particular meteorological conditions for one or more d&b loudspeaker systems.

A 3D terrain map imported from Google Maps or Street View displays the calculated immission on the areas surrounding the audience listening zones. This visual representation shows the actual system performance in the far field, enabling users to optimize for listeners while satisfying local noise restrictions and offsite regulations.

To ensure reliable results, NoizCalc includes all complex data concerning the addition and subtraction of sound waves, including phase information to describe the combination and interaction effects within a loudspeaker system consisting of multiple line arrays, subwoofer arrays and delay systems.

NoizCalc models immissions in the far field according to the internationally accepted ISO 9613-2, CNOSSOS or Nord2000 calculation standards. Ground characteristics can be set depending on the absorbency or reflectivity of surfaces, while areas with volume attenuating properties can be defined. Buildings can be included, and the maximum reflection order option adjusts how many reflections are calculated. Parameters for humidity, air pressure and temperature ensure that the correct air absorption figures are accounted. The ISO 9613-2 standard requires limited meteorological information and assumes a worst-case scenario. The more sophisticated propagation model, Nord2000 enables a more precise handling of meteorological conditions allowing the user to model with prevailing wind information. The d&b NoizCalc immission modelling software is available at [www.dbaudio.com](http://www.dbaudio.com) for registered download, along with further information and video tutorials. It was developed in collaboration with SoundPLAN, a specialist software developer for environmental noise prediction.

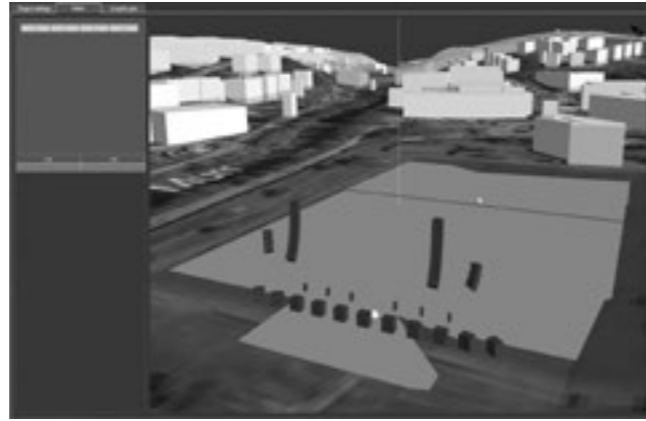

Editor



Graphic plot

# The d&b R1 Remote control software

The remote control capability of the d&b Remote Network enables central control and monitoring of a complete d&b loudspeaker system from anywhere in the network, be it from a computer in the control room, at the mix position, or on a wireless tablet in the auditorium. This central access to all functions throughout the d&b Remote Network unlocks the full potential of the d&b system approach. In a typical user workflow, the d&b Remote Network takes settings optimized in the d&b ArrayCalc simulation software and applies these to all the amplifiers within the network.

All functions and controls available on the front panel of d&b amplifiers may be remotely controlled and/or monitored using the d&b R1 Remote control software. This allows each channel of the amplifier to be controlled and enables the creation of groups of loudspeakers. When grouped together, a button or fader can control the overall system level, zone level, equalization and delay, power ON/OFF, MUTE, as well as loudspeaker specific function switches such as CUT/HFA/HFC and CPL. An offline mode is provided for preparation in advance of an event, without the amplifiers being present or connected.

d&b System check verifies that the system performs within a predefined condition, while the Array verification function automatically identifies the physical position of a loudspeaker in an array to check that the system is cabled correctly. Extensive facilities for storing and recalling system settings are provided allowing these to be repeated, as and when required. For mobile applications, project files can be easily adjusted for use with a different set of equipment at another location.

The R1 software is optimized for use with touch screen, mouse and keyboard and runs on both Microsoft Windows<sup>1</sup> (Win7 64-bit or later) and Mac OS X<sup>2</sup> (10.12 or later).

Further information is provided in the d&b Amplifier and Software brochure which is available for download at [www.dbaudio.com](http://www.dbaudio.com).



R1 home screen



R1 in configuration mode

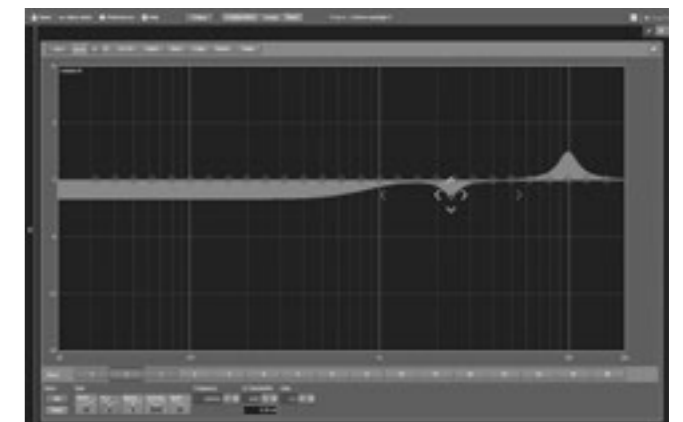

D20/D80 16-band equalizer in R1

<sup>1</sup> Microsoft Windows is a registered trademark or trademark of Microsoft Corporation in the United States and/or other countries

<sup>2</sup> Mac OS X is a trademark of Apple Inc., registered in the U.S. and other countries

# The DS10 and DS20 Audio network bridges

## The DS100 Signal Engine

### DS10 Audio network bridge

The DS10 Audio network bridge interfaces between Dante networks and AES3 digital audio signals, while also providing distribution of Ethernet control data. Positioned within the signal chain in front of the amplifiers, this 1 RU device expands the d&b system approach. Each unit can deliver up to sixteen Dante network channels via AES3 digital signal outputs. Additionally, four AES3 input channels provide access to the Dante audio network for applications such as a break-in from a Front of House console. The DS10 incorporates an integrated 5-port switch, offering a primary and redundant network for the Dante protocol, as well as advanced functions such as Multicast Filtering and VLAN modes. Using the DS10 Audio network bridge, audio signals and remote control data can be combined using a single Ethernet cable.



The DS10 Audio network bridge front view



The DS10 Audio network bridge rear view

### DS20 Audio network bridge

The DS20 Audio network bridge supports the open standards-based Milan protocol rather than Dante. Milan (Media integrated local area networking) is a high level interoperability solution based on Audio Video Bridging (AVB) technology. The main advantages are deterministic behaviour (zero network congestion); improved reliability; optimum synchronization and hassle free network setup, as no special settings, such as QoS, need to be set within the switches to ensure delivery.



The DS20 Audio network bridge front view



The DS20 Audio network bridge rear view

### DS100 Signal Engine

The DS100 Signal Engine is the platform underneath the Soundscape, based on a specialized rack mount 3 RU audio processor with Audinate Dante networking. It provides a 64 x 64 audio matrix with level and delay adjustments at all cross points. Additional software modules provide dynamic source positioning and emulated acoustics functions. The DS100 is a versatile tool for use within complex audio systems to route and distribute multiple audio channels to numerous amplifiers driving loudspeaker positions and zones, show relay and break out rooms. The networking capabilities with a Dante enabled processor are significant, particularly for busy, multi-room complexes. The DS100 completely integrates with the overall d&b system approach, including loudspeakers, amplifiers, rigging, transport and networking accessories and the DS10 Audio network bridge. The complete system is designed and optimized in the d&b ArrayCalc simulation software, and controlled via the d&b R1 Remote control software.



The DS100 Signal Engine front view



The DS100 Signal Engine rear view

# The D40 and D80 amplifiers

The 2 RU four channel D40 and D80 amplifiers are high power density amplifiers, ideally suited for use in mobile environments. The signal delay capability enables user definable settings of up to 10 s (= 3440 m/11286 ft) to be applied independently to each channel. The same applies to the two 16-band equalizers, providing optional parametric, asymmetric, shelving or notch filtering. The amp incorporates a colour TFT touchscreen, offering quick access to the menu structure, while the rotary encoder can be used for fine adjustment. The front panel and the

integrated touchscreen of the D40 and D80 amplifiers are tilted up for ease of operation when the amplifier is below eye level. The LoadMatch function integrated within the amplifiers electrically compensates the properties of loudspeaker cable used. The D40 and D80 incorporate Class D amplifiers utilizing a switched mode power supply with active Power Factor Correction (PFC) suitable for mains voltages 100 V/127 V, 50 - 60 Hz and 208 V/240 V, 50 - 60 Hz and maintains a stable output when used with weak or unstable mains supplies.

	D40	D80
<b>User interface</b>	Encoder/colour TFT touchscreen	Encoder/colour TFT touchscreen
<b>Output channels</b>	4	4
<b>Input channels</b>	4 x AES3 or 4 x analog	4 x AES3 or 4 x analog or 2 x AES3 and 2 x analog
<b>Latency</b>	0.3 msec	0.3 msec
<b>User equalizers (per channel)</b>	2 x 16-band	2 x 16-band
<b>Delay</b>	10 sec/3440 m	10 sec/3440 m
<b>Maximum output power (THD+N &lt; 0.5%, 12 dB crest factor)</b>	4 x 2000 W into 8 ohms 4 x 2400 W into 4 ohms	4 x 2000 W into 8 ohms 4 x 4000 W into 4 ohms
<b>Output routing</b>	Dual Channel, Mix TOP/SUB 2-Way Active	Dual Channel, Mix TOP/SUB 2-Way Active
<b>Output connectors</b>	NL4 plus central NL8	NL4 plus central NL8
<b>Cable compensation</b>	LoadMatch	LoadMatch
<b>Power supply</b>	Autosensing switched mode power supply with active PFC	Autosensing switched mode power supply with active PFC
<b>Mains voltage</b>	100 - 127/208 - 240 V, 50 - 60 Hz	100 - 127/208 - 240 V, 50 - 60 Hz
<b>Weight (kg/lb)</b>	13.8/30.4	19/42
<b>Dimensions</b>	2 RU x 19" x 465 mm	2 RU x 19" x 530 mm
<b>Remote</b>	OCA/AES70 via Ethernet	OCA/AES70 via Ethernet/CAN

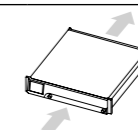
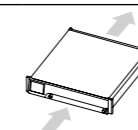

# The D40 and D80 Touring rack assemblies

Touring rack assemblies are designed as a complete prewired system amplification rack providing mains power distribution, connector interfaces and all internal cabling for D40 and D80 amplifiers.

## D80 Touring Rack

Touring racks for the D80 are available in both 6 x D80 and 3 x D80 versions. A 19" internal shockmount steel frame accommodates an I/O panel providing both analog and digital audio signals as well as four network connectors for either Ethernet or CAN-Bus remote networking and a d&b DS10 or DS20 Audio network bridge. The d&b Audio network bridges interface between audio transport networks and AES3 digital audio signals while also providing distribution of Ethernet control data. The DS10 supports Dante networks, while the DS20 is used for the open standards-based Milan protocol. The Audio network bridges each incorporate an integrated 5-port switch, offering a primary and redundant network. The DS20 5-port switch is fully AVB enabled, while the DS10 offers special functions such as Multicast Filtering and VLAN modes.

The d&b 6 x D80 Touring rack assembly comes with a 2 RU loudspeaker connector panel providing six NL8 (4 channel) and two LKA25 (12 channel) loudspeaker outputs. The loudspeaker connector panel is also equipped with a Power over Ethernet (PoE) socket to connect and power a d&b ArraySight inclinometer.

The d&b 3 x D80 Touring rack assembly provides three NL8 (4 channel) and one LKA25 (12 channel) loudspeaker output. Both touring Racks are available with a 32 A CEE mains power distribution or 30 A NEMA mains power distribution panel.

## D40 Touring rack

Touring racks for the D40 are available in both 6 x D40 and 3 x D40 versions. A 19" internal shockmount steel frame accommodates an I/O panel providing both analog and digital audio signals via XLR connection.

D40 amplifiers connect using a star topology, with the d&b DN1 Network switch acting as the central connection site. The DN1 Network switch incorporates eight RJ45 ports at the rear of the unit and three etherCON ports at the front. Two of these are equipped with as well as a Power over Ethernet (PoE) socket used to connect and power accessories such as the ArraySight sender unit.

The d&b 6 x D40 Touring rack assembly provides six NL8 (4 channel) and two LKA25 (12 channel) loudspeaker outputs. The d&b 3 x D40 Touring rack assembly provides three NL8 (4 channel) and one LKA25 (12 channel) loudspeaker output.

Both touring Racks are available with a 32 A CEE mains power distribution or 30 A NEMA mains power distribution panel.

## d&b ArraySight

The d&b ArraySight inclinometer system is intended to vertically aim an entire array in its operation position. It provides precision angle measurement over a wide measuring angle of  $\pm 90$  degrees. It utilizes an ultra bright green laser to provide a visible indication for aiming the array. The d&b ArraySight sender unit also sends temperature and humidity information to the R1 Remote control software via OCA/AES70.



6 x D80 Touring rack front view



6 x D40 Touring rack front view



3 x D80 Touring rack front view



3 x D40 Touring rack front view

# The SL-Series system package

The full functionality of any d&b system is instantly inherited from a software suite for planning, modelling and control. This includes ArrayCalc, ArrayProcessing, NoizCalc, and the R1 Remote control software. The DS10 and DS20 Audio network bridges provide connectivity to Dante and Milan networks respectively. Positioned within the signal chain in front of the amplifiers, these 1 RU devices expand the d&b system approach in both mobile and installation environments.

At the heart are the D80 and D40 Touring rack assemblies which house three and six amplifiers, respectively and utilize the MC24/LKA25 loudspeaker multicore solution.

The 3 x D40/D80 rack provides a single multicore connector that will power an array of six XSL loudspeakers, while the 6 x D40/D80 rack offers two multicore connectors that will power an array of twelve XSL loudspeakers with ArrayProcessing.

The d&b SL-Series is a special loudspeaker system, a complete package guaranteeing consistency in transport, cabling, amplification, rigging and operation, with all the performance and reliability advantages of the d&b System reality.



GSL/KSL/XSL System package

# The controller setups and operation with D40 and D80 amplifier

## Arc and Line setup

The Arc mode is used for line array loudspeakers when used in curved array sections with splay angles between 2° and 7°. The Line mode is used for long throw array sections with three or more consecutive splay settings between 0° and 1°. Compared to the Arc mode, the upper mid range is reduced to compensate for the extended near field.

## AP setup

In connection with ArrayProcessing (AP), the AP setup contains the AP data that are generated in the ArrayCalc simulation software. These are transferred to the applicable amplifiers via the d&b Remote network (OCA/AES70) using R1.

## CUT mode

Set to CUT, the cabinet low frequency level is reduced and it is now configured for use with the d&b SL subwoofer.

## HFC mode

Selecting the HFC (High Frequency Compensation) mode compensates for loss of high frequency energy due to absorption in air when loudspeakers are used to cover far field listening positions. HFC has two settings which should be used selectively, HFC1 for cabinets covering distances larger than 40 m (130 ft) and HFC2 for those covering distances larger than 80 m (260 ft). This can be used to achieve the correct sound balance between close and remote audience areas allowing all amplifiers driving the array to be fed from the same signal source. Thus the whole array performs with comparable headroom.

## CPL function

The CPL (Coupling) function compensates for coupling effects between closely coupled cabinets by reducing the low and mid frequency level. SL-Series CPL has been enhanced and allows independent shaping of low and low-mid frequency responses using a dual-stage filter. This enables full use of the extended SL-Series LF headroom. The classic CPL function remains for J-, V-, Y- and T-Series arrays, and uses a single low shelving-like filter response.

## INFRA mode

With the INFRA mode selected, the frequency response of the system extends from 33 Hz to 75 Hz, the KSL-SUB/KSL-GSUB can now be used to supplement applicable d&b loudspeaker systems operated in full range mode.

With the INFRA mode selected for the SL-SUB/SL-GSUB, the frequency response of the system extends from 30 Hz to 65 Hz. The SL-SUB/SL-GSUB can now be used to supplement applicable d&b loudspeaker systems operated in full range mode.

## Maximum loudspeakers per amplifier

	KSL8	KSL12	KSL-SUB	KSL-GSUB	SL-SUB	SL-GSUB
<b>D40<sup>1</sup></b>	2	2	2	2		
<b>D40</b>	4	4	2	2		
<b>D80<sup>1</sup></b>	2	2	2	2	2	2
<b>D80</b>	4	4	2	2	2	2

## Available controller settings

	KSL8	KSL12	KSL-SUB	KSL-GSUB	SL-SUB	SL-GSUB
<b>Arc/Line</b>	x	x				
<b>AP</b>	x	x	x		x	
<b>CUT</b>	x	x				
<b>HFC</b>	x	x				
<b>CPL</b>	x	x				
<b>INFRA</b>			x	x	x	x

# The KSL System frequency responses

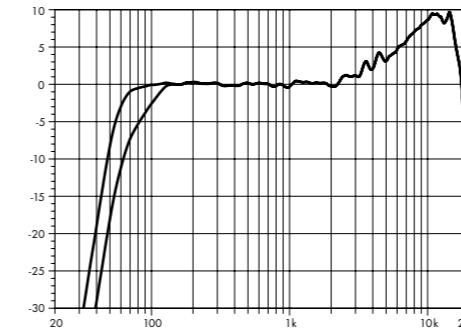

KSL8 frequency response, standard and CUT modes<sup>1</sup>

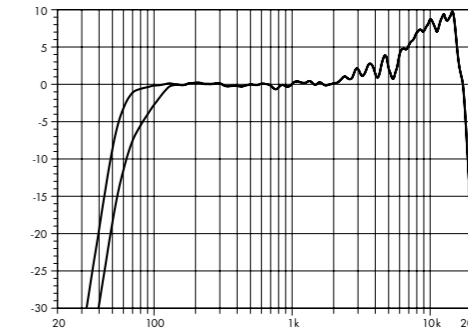

KSL12 frequency response, standard and CUT modes<sup>1</sup>

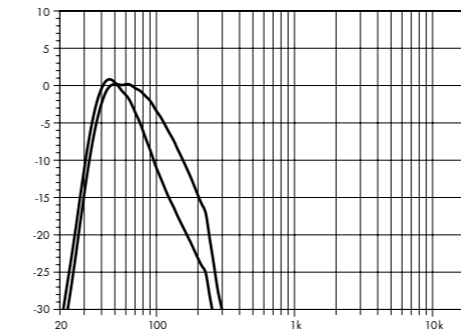

KSL-SUB/KSL-GSUB frequency response, standard and INFRA modes

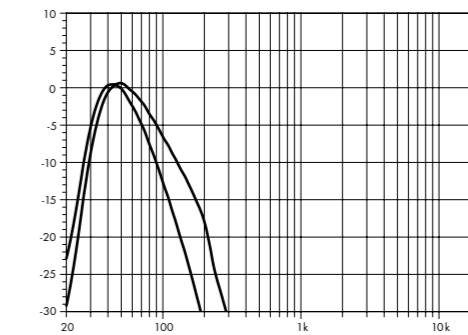

SL-SUB/SL-GSUB frequency response, standard and INFRA modes

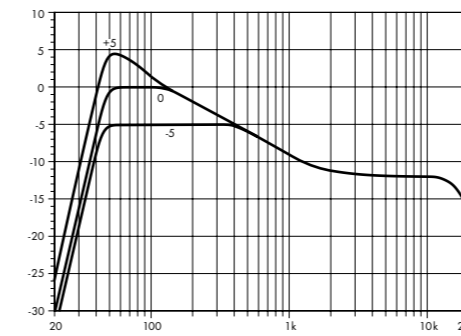

SL-CPL Low<sup>2</sup>

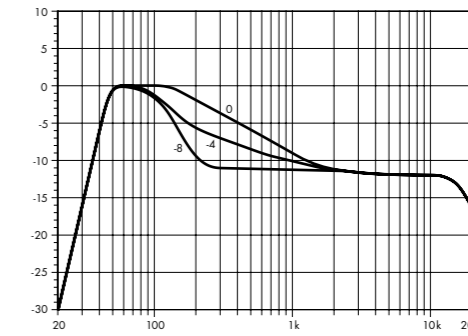

SL-CPL Mid<sup>2</sup>

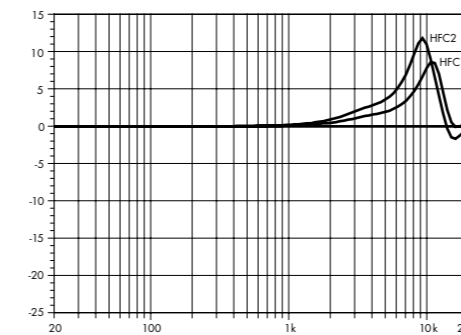

Correction of HFC<sup>2</sup>

# The KSL System configuration examples

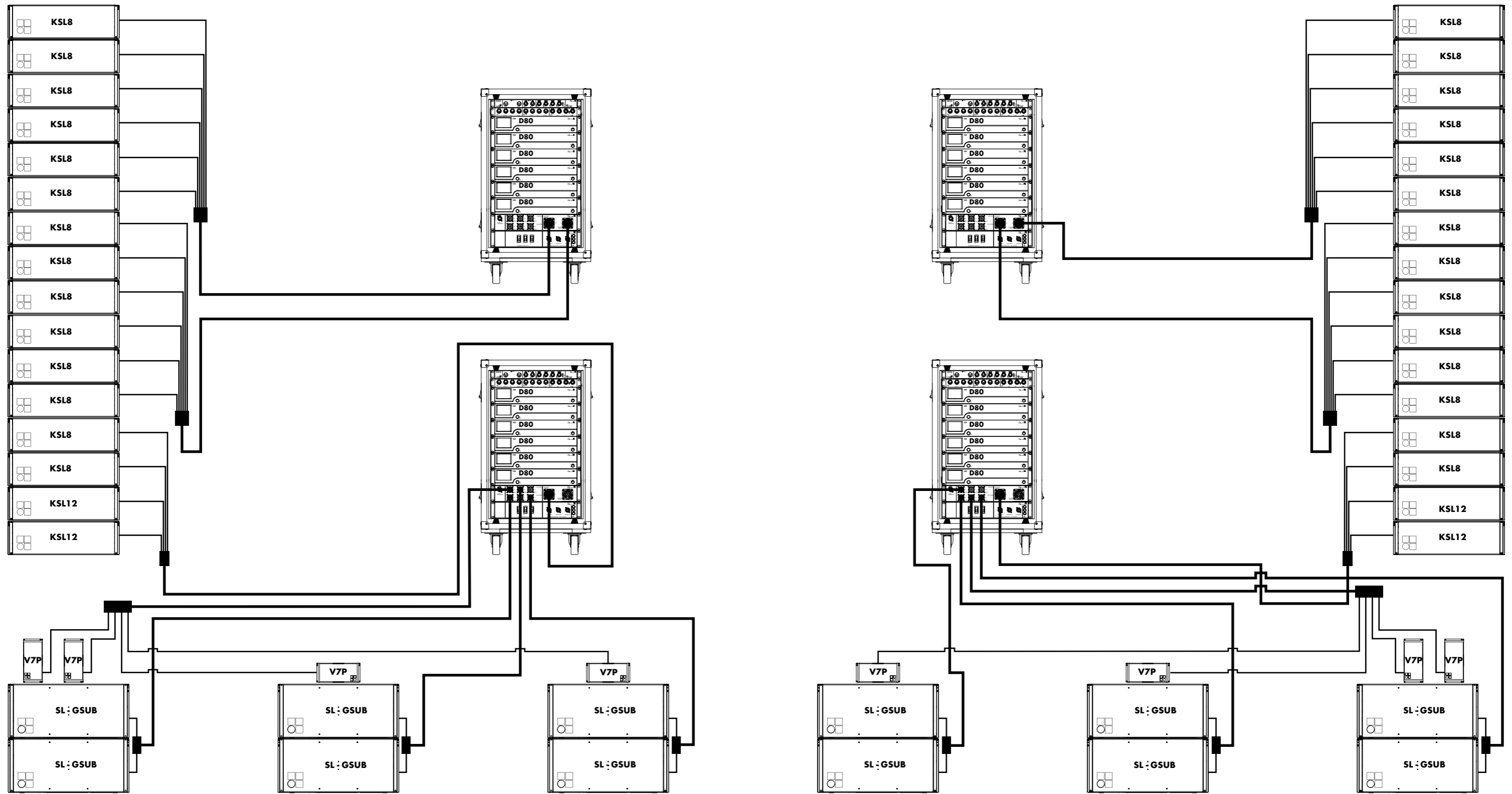

SL-Series arena configuration comprising KSL8/KSL12 mains and V7P frontfills along with ground stacked SL-GSUB with 6 x D80 Touring racks

# The KSL System configuration examples

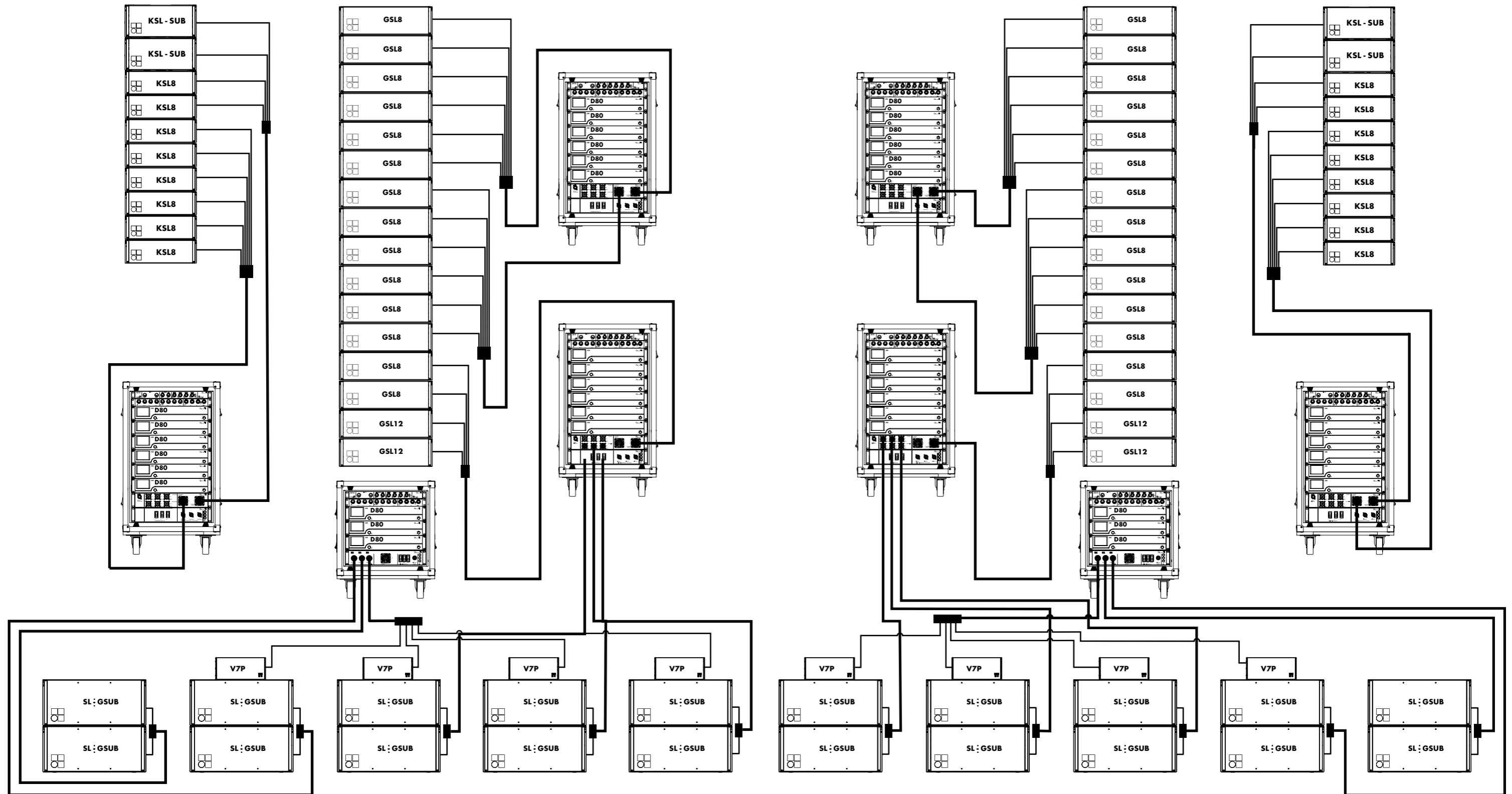

SL-Series festival configuration comprising GSL8/GSL12 mains, KSL-SUB/KSL8 outfills and V7P frontfills along with ground stacked SL-GSUB with 6 x D80 and 3 x D80 Touring racks



# The KSL System cables and adapters MC8/MC24

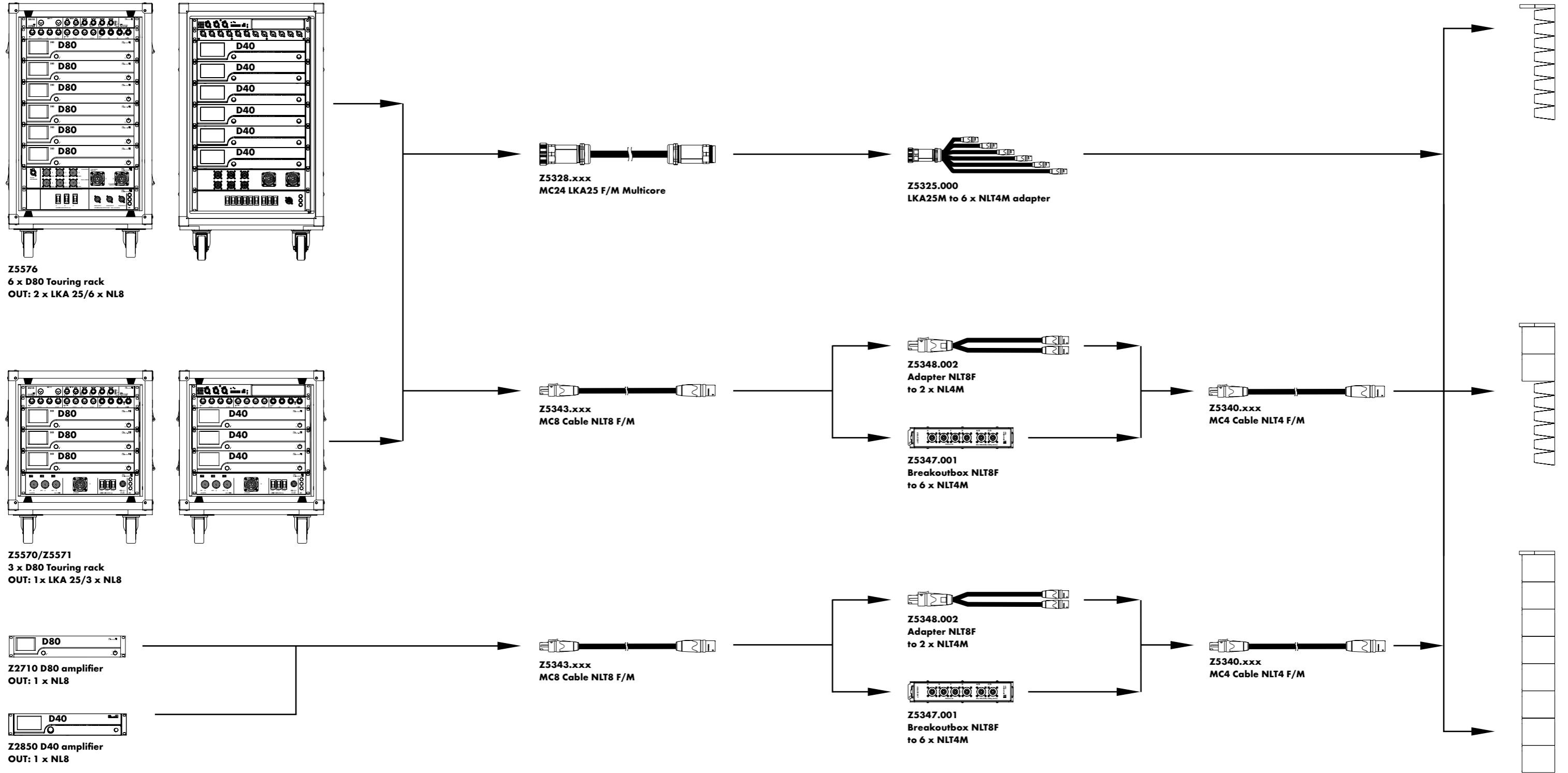

# The KSL System product overview

<b>KSL loudspeakers</b>	Z0780.000	<b>KSL8 Loudspeaker NLT4F/M</b>	<b>Processing and distribution</b>	Z4010.000	<b>DS10 Audio network bridge</b>	
	Z0781.000	<b>KSL12 Loudspeaker NLT4F/M</b>		Z4011.000	<b>DS20 Audio network bridge</b>	
	Z0785.000	<b>KSL-SUB NLT4F</b>		Z4100.000	<b>DS100 Signal Engine</b>	
	Z0786.000	<b>KSL-GSUB NLT4F</b>				
	Z0760.000	<b>SL-SUB NLT4F</b>				
Z0761.000	<b>SL-GSUB NLT4F</b>					
<b>KSL accessories</b>	Z5721.000	<b>KSL Flying frame set</b>	<b>Amplifiers</b>	Z2850.xxx	<b>D40 Amplifier<sup>6</sup></b>	
	Z5724.000	<b>KSL Compression set</b>		Z2710.xxx	<b>D80 Amplifier<sup>6</sup></b>	
	Z5731.000	<b>KSL Stacking frame</b>				
	Z5707.000	<b>SL Aiming plate</b>				
	Z5706.000	<b>Hoist Connector chain 4t</b>	<b>Amplifier rack assemblies</b>	Z5600.xxx	<b>3 x D40 Touring rack</b>	
	Z5747.000	<b>KSL-SUB Adapter frame</b>		Z5601.xxx	<b>6 x D40 Touring rack</b>	
	Z5762.000	<b>d&amp;b ArraySight Meter Unit</b>		Z5570.xxx	<b>3 x D80 Touring rack<sup>7</sup></b>	
	E7800.000	<b>KSL-SUB/KSL-GSUB transport lid</b>	Z5571.xxx	<b>3 x D80 Touring rack (includes DS10)<sup>7</sup></b>		
	E7499.000	<b>SL-SUB/SL-GSUB transport lid</b>	Z5576.xxx	<b>6 x D80 Touring rack (includes DS10)<sup>7</sup></b>		
	E7494.000	<b>SL Outriggers</b>				
	<b>Cart packages</b>	Z5726.000	<b>KSL8 Cart package<sup>1</sup></b>	<b>Racks</b>	E7468.000	<b>D40/D80 Touring rack 2 RU, 19" SD, shock mounted, handles</b>
Z5727.000		<b>KSL12 Cart package<sup>1</sup></b>	E7483.000		<b>DS100 Touring rack 3 RU, 19" SD, shock mounted, handles</b>	
Z5729.000		<b>KSL8 Tension cart package<sup>2</sup></b>	<b>Cables and adapters</b>	Z5343.xxx	<b>MC8 Cable NLT8 F/M</b>	
Z5730.000		<b>KSL12 Tension cart package</b>		Z5340.xxx	<b>MC4 Cable NLT4 F/M</b>	
Z5728.000		<b>3x KSL-SUB Cart package<sup>3</sup></b>		Z5328.xxx	<b>MC24 LKA 25 F/M Multicore</b>	
Z5732.000		<b>3x KSL-GSUB Cart package<sup>3</sup></b>		Z5325.000	<b>Adapter LKA25M to 6 x NLT4M</b>	
Z7493.760		<b>2 x SL-SUB Cart package<sup>4</sup></b>		Z5348.002	<b>Adapter NLT8F to 2 x NLT4M</b>	
Z7493.761		<b>2 x SL-GSUB Cart package<sup>4</sup></b>		Z5347.001	<b>Breakoutbox NLT8F to 6 x NLT4M</b>	
Z7492.760		<b>3 x SL-SUB Cart package<sup>5</sup></b>				
Z7492.761		<b>3 x SL-GSUB Cart package<sup>5</sup></b>				
<b>Carts and cases</b>	E7802.000	<b>Touring cart 4 x KSL8/KSL12</b>				
	E7495.000	<b>Touring cart 4 x KSL8/KSL12 tension</b>				
	E7496.000	<b>Touring cart cover KSL8/KSL12</b>				
	E7804.000	<b>Touring cart KSL-SUB</b>				
	E7805.000	<b>Touring cart cover 3 x KSL-SUB</b>				
	E7492.000	<b>Touring cart SL-SUB</b>				
	E7498.000	<b>Touring cart cover 2 x SL-SUB</b>				
	E7493.000	<b>Touring cart cover 3 x SL-SUB</b>				
	E7801.000	<b>Touring case KSL compression</b>				

<sup>1</sup> Includes 4 x KSL8/12 loudspeakers, KSL Touring cart and KSL Touring cart cover

<sup>2</sup> Includes 4 x KSL8/12 loudspeakers, KSL Touring cart tension and KSL Touring cart cover

<sup>3</sup> Includes 3 x KSL-SUB/KSL-GSUB subwoofers, KSL-SUB touring cart and KSL-SUB Touring cart cover

<sup>4</sup> Includes 2 x SL-SUB/SL-GSUB subwoofers, SL-SUB Touring cart and SL-SUB Touring cart cover

<sup>5</sup> Includes 3 x SL-SUB/SL-GSUB subwoofers, SL-SUB Touring cart and SL-SUB Touring cart cover

All Touring cart covers can be extended to house a mounted Flying frame

<sup>6</sup> The complete list of mobile amplifier versions is available in the d&b D Amplifier and Software brochure

<sup>7</sup> Further information is available in the d&b D Amplifier and Software brochure

