

KSLi

SL-Series

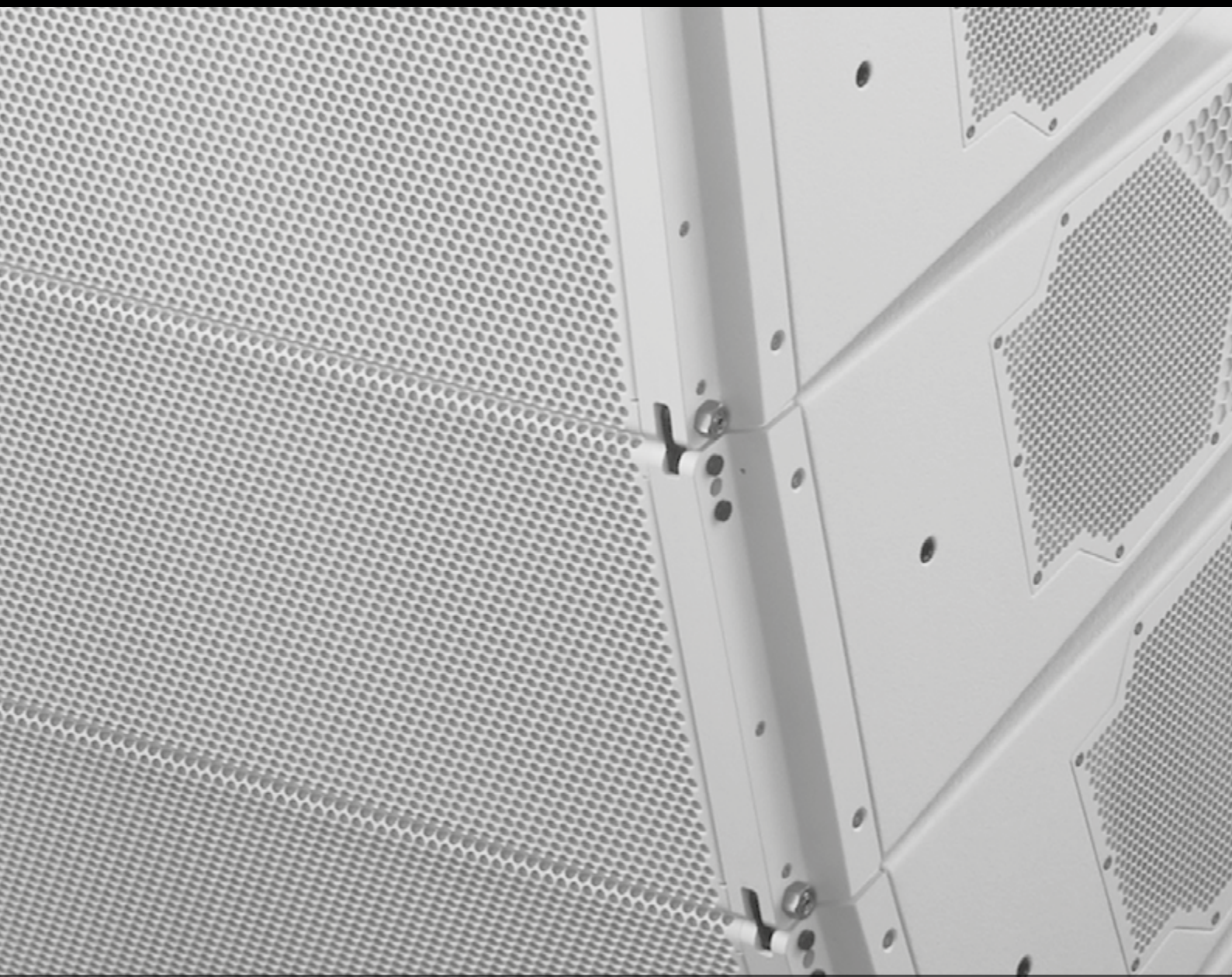

Contents



The d&b System reality	4
The SL-Series	6
The KSLi System	8
The KSLi8 loudspeaker	10
The KSLi12 loudspeaker	11
The KSLi-SUB and KSLi-GSUB	12
The KSLi Weather Resistant, Special Colour and Custom solutions options	13
The KSLi rigging system	14
The KSLi rigging examples	15
The d&b ArrayCalc simulation software	16
The d&b NoizCalc immission modelling software	18
The d&b R1 Remote control software	19
The DS10 and DS20 Audio network bridges	20
The DS100 Signal Engine	20
40D amplifier	21
The controller setups and operation with 40D amplifier	22
The KSLi System frequency responses	23
The KSLi System configuration examples	24
The KSLi System product overview	30

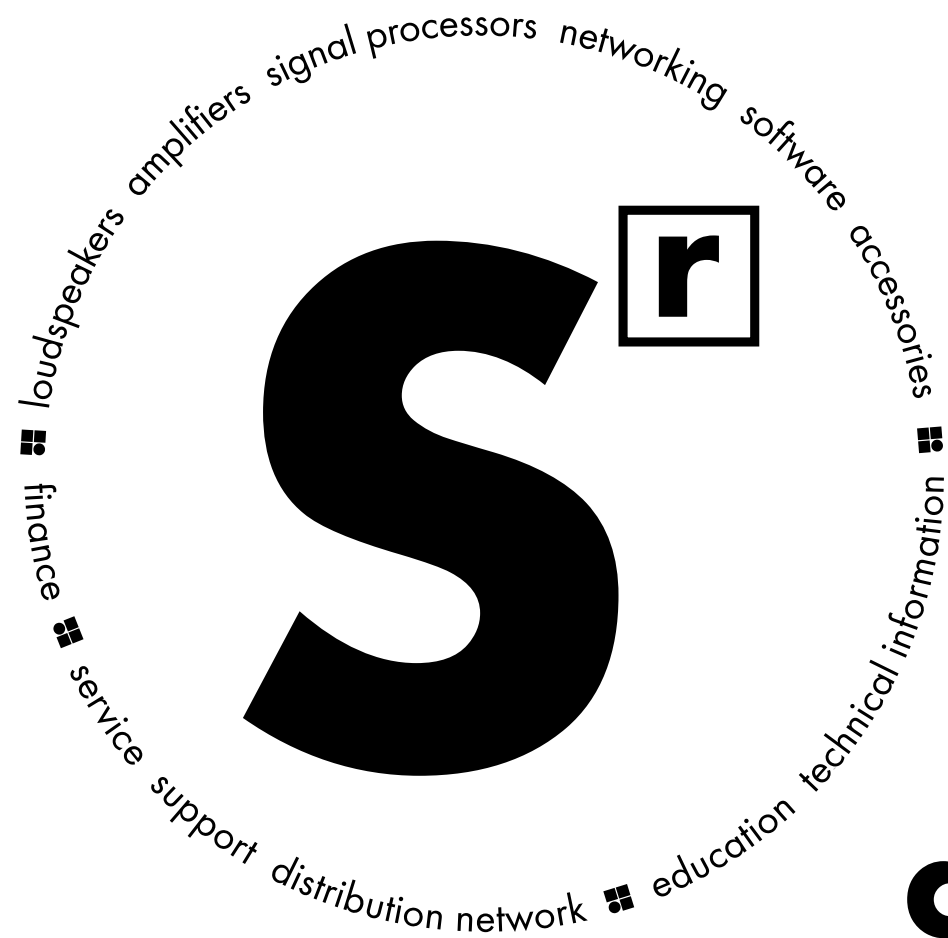

d&b System reality

As the name implies a d&b audiotechnik system is not just a loudspeaker. Nor is it merely a sum of the components: loudspeakers, amplifiers, signal processors, networking, software and accessories. Right from the outset the d&b audiotechnik approach was to build integrated sound reinforcement systems

that actually are more than the combination of parts: an entirety where each fits all. Every element is tightly specified, precisely aligned and carefully matched to achieve maximum efficiency. For ease of use, all the user-definable parameters are incorporated, allowing the possibility of adjustment, either

directly, via remote control surfaces, or integrated within wider networks. Neutral sound characteristics leave the user all the freedom needed to realize whatever the brief. At the same time d&b offers finance, service and support, a knowledgeable distribution network, education and training as well as technical

information, so the same optimal acoustic result is achieved consistently by every system anywhere, at any time. In reality: the d&b System reality.

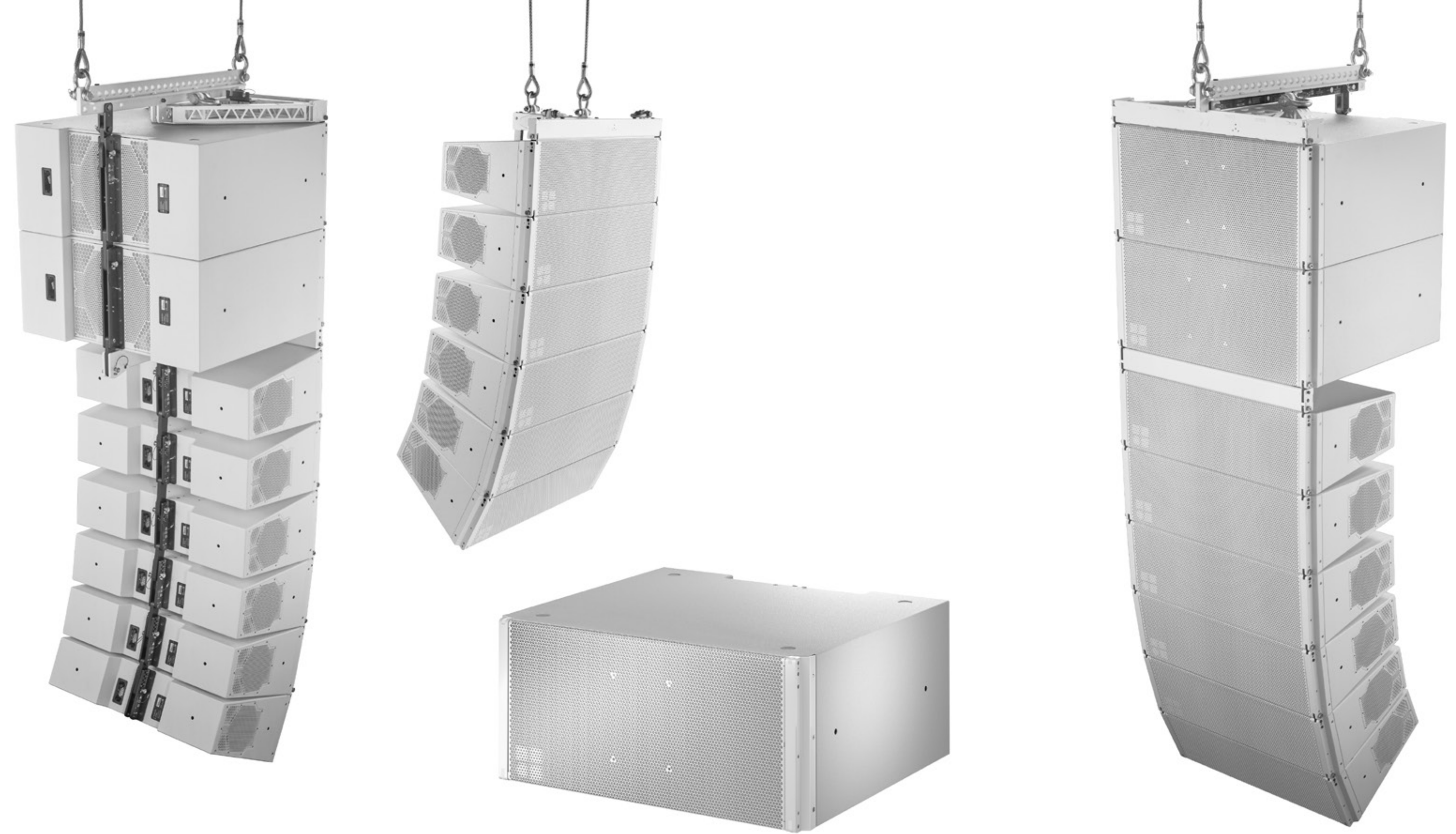

A complete dedicated installation solution with broadband directivity embedded in its DNA. The SL-Series' GSL, KSL and KSLi Systems are complete packages carefully honed for mobile and installation needs. Independent but sonically compatible, KSL and GSL are specifically designed to accurately convey messages across all performance styles and musical genres, in theaters,

concert halls, stadiums and arenas, festivals and more. The systems deliver unprecedented directivity control and headroom over the entire audio spectrum and significant low frequency extension. For projects on the go, comprehensive rigging, cabling and transportation solutions enable the highest speed of deployment. Precise broadband directivity control curtails

energy radiating to the rear of the loudspeakers, right down to the lowest frequencies. This reduces the level radiating back to the stage, creating more comfortable performance environments and diminishing lower frequency spill on open mics. Indoors, accurate directivity control significantly decreases stimulation of the reverberant field, while outdoors it keeps energy focused on

the audience, substantially reducing unwanted immissions. As with all d&b systems, KSLi neatly aligns with every element of the tried and tested d&b Workflow, including system design, deployment, optimization and control, for consistently unparalleled audio performance and maximum efficiency, everytime.

The KSLi System

The **KSLi System** is a complete dedicated installation solution designed to address the broadest range of applications, wherever high quality sound reinforcement and reproduction are a prerequisite. As the installation variant of the KSL System, KSLi differs only in cabinet construction and mounting hardware. All KSLi cabinets and accessories can be custom color matched to interiors and/or weather protected as standard.

The **KSLi8 and KSLi12** line array modules are specifically designed for medium to large scale sound reinforcement. Sharing the same vertical directivity, size, footprint, weight, rigging and driver complement, up to twenty-four KSLi loudspeakers can be flown in vertical columns. The 2-Way active design combines ingenious cabinet geometry with forward and side firing low frequency drivers, these couple towards the front, cancel towards the rear and increase low frequency headroom. The driver compliment is completed by a hornloaded mid range and two high frequency drivers mounted to a waveshaping device. The 80° horizontal directivity pattern of the KSLi8 is seamlessly maintained down to the lowest frequencies the loudspeaker produces, while the high output capability can cover a distance range of over 100 m (330 ft), depending on the climatic conditions. The KSLi12 has a wider horizontal dispersion pattern of 120° which is also maintained over the entire operating range.

The **KSLi-SUB** and **KSLi-GSUB** extend the bandwidth of a KSLi System down to 36 Hz (33 Hz in INFRA mode) as well as increasing its headroom. The subwoofers' bass-reflex design uses three 15" high excursion drivers, one of which radiates to the rear, producing a cardioid performance that avoids unwanted energy behind the system. The KSLi-SUB is equipped with flying fittings, while the KSLi-GSUB is intended for ground stacked use only.

The KSLi-SUB and KSLi-GSUB can be configured in conventional left and right ground stacked setups as well as in distributed SUB arrays to achieve an even venue specific coverage pattern. The KSLi-SUB cabinet incorporates front and rear rigging strands while the KSLi-GSUB has no rigging components. Custom rigging solutions are available by request to meet individual project requirements.



KSLi8 loudspeaker



KSLi12 loudspeaker



KSLi-SUB



KSLi-GSUB

The d&b **ArrayCalc** simulation software allows the virtual optimization of line arrays, point source and column loudspeakers as well as subwoofers and their adjustment to venue conditions. The d&b **NoizCalc** immission modelling software uses international standards to model noise immission from d&b loudspeaker systems. NoizCalc takes data from ArrayCalc and calculates the sound propagation towards the far field. The complete system configuration simulated in ArrayCalc is assimilated by the d&b **R1** Remote control software into an intuitive graphical user interface to manage the system from anywhere in the venue.

A wide range of tools and data files are available to support the planning process using external tools. For enhanced acoustic simulations, all loudspeakers offer EASE files. BIM (Building Information Modelling) is supported with Revit files available for all loudspeakers and accessories, creating accurate project data and visualization. 2D and 3D CAD data is usable in most common planning tools. Venue data created by SketchUp can be imported to ArrayCalc using the d&b sketchup plug-in to facilitate system design.

d&b amplifiers are specifically designed for use with d&b loudspeakers, and are at the heart of the d&b system approach. These devices contain extensive Digital Signal Processing capabilities to provide comprehensive loudspeaker management and specific switchable filter functions to precisely target the system response for a wide variety of applications. The four channel **40D** amplifier is intended for installation applications requiring the highest Sound Pressure Levels. The 40D amplifier provide extensive user-definable equalization containing two 16-band equalizers with parametric, notch, shelving and asymmetric filters as well as delay capabilities of up to 10 seconds.

The d&b Audio network bridges interface between audio transport networks and AES3 digital audio signals while also providing distribution of Ethernet control data. The **DS10** supports Dante networks, while the **DS20** is used for the open standards-based Milan protocol.

The **DS100** Signal Engine is a specialized rack mount 3 RU audio processor with Dante networking. It provides a 64 x 64 audio matrix with level and delay adjustments at all cross points. Additional software modules provide source positioning and emulated acoustics functions.



40D amplifier



DS10 Audio network bridge



DS20 Audio network bridge



DS100 Signal Engine

The KSLi8 loudspeaker

KSLi8 loudspeaker

The KSLi8 line array module produces an 80° constant directivity dispersion pattern in the horizontal plane over the entire operating bandwidth. The KSLi8 houses two 10" neodymium forward facing LF drivers and two side firing 8" neodymium LF drivers. A coaxial mid-high section contains an MF horn with a 8" driver and two 1.4" exit HF compression drivers with 3" voice coils mounted to a wave shaping device. SL-Series flying hardware has a patented workflow with integrated tension rigging mode, allowing splay angles from 0° to 10° in 1° increments. The loudspeakers are driven actively by two channels of an appropriate d&b amplifier. One channel powers the 10" LF drivers, the second channel powers all other components, which are passively crossed-over. The component geometry provides consistent, accurate horizontal dispersion control, which the front and side firing LF driver arrangement maintains seamlessly down to the lowest frequencies produced. Expanding flexibility for applications where ArrayProcessing is not required, the KSLi8 includes the option to link two cabinets in Arc/Line modes. The cabinets are constructed from marine plywood and have an impact and weather protected PCP (Polyurea Cabinet Protection) finish. The front and side panels incorporate rigid metal grills backed by an acoustically transparent and water repellent fabric.

System data

Frequency response (-5 dB standard) 54 Hz - 18 kHz
 Frequency response (-5 dB CUT mode) 75 Hz - 18 kHz
 Max. sound pressure (1 m, free field)
 with 40D 145 dB¹

Loudspeaker data

Nominal impedance front LF 8 ohms
 Nominal impedance side LF/MF/HF 8 ohms
 Power handling capacity front LF (RMS/peak 10 ms)
 450/1800 W
 Power handling capacity side LF/MF/HF (RMS/peak 10 ms)
 250/1000 W
 Nominal dispersion angle (horizontal) 80°
 Splay angle settings 0 - 10° (1° increment)
 Components 2 x 10" front LF driver
 2 x 8" side LF driver
 1 x 8" MF driver
 2 x 1.4" exit compression driver with 3" voice coil
 Passive crossover network
 Connections NLT4 F/M
 Phoenix socket
 Weight 57 kg (126 lb)

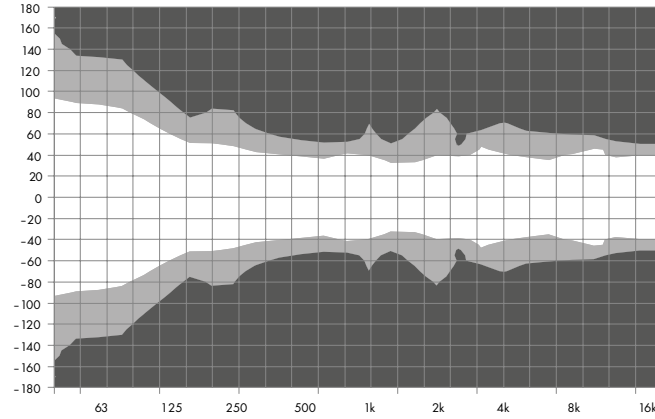

KSLi8 horizontal dispersion characteristics²

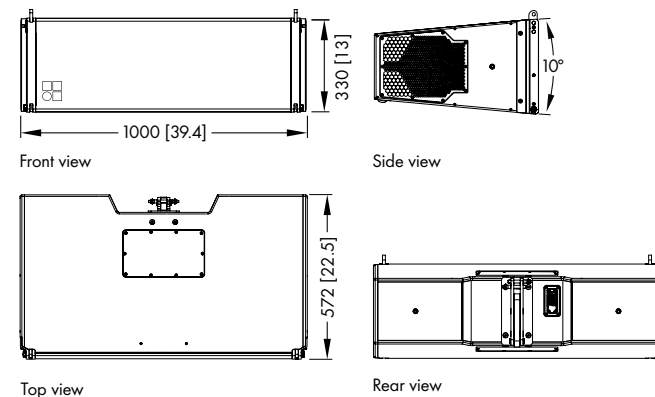

KSLi8 cabinet dimensions in mm [inch]

¹ SPLmax: Broadband signal IEC 60268
² Dispersion angle vs frequency plotted using lines of equal sound pressure (isobars) at -6 dB and -12 dB

The KSLi12 loudspeaker

KSLi12 loudspeaker

The KSLi12 line array module produces an 120° constant directivity dispersion pattern in the horizontal plane over the entire operating bandwidth. The KSLi12 houses two 10" neodymium forward facing LF drivers and two side firing 8" neodymium LF drivers. A coaxial mid-high section containing an MF horn with a 8" driver and two 1.4" exit HF compression drivers with 3" voice coils mounted to a wave shaping device. SL-Series flying hardware has a patented workflow with integrated tension rigging mode, allowing splay angles from 0° to 10° in 1° increments. The loudspeakers are driven actively by two channels of an appropriate d&b amplifier. One channel powers the 10" LF drivers, the second channel powers all other components, which are passively crossed-over. The component geometry provides consistent, accurate horizontal dispersion control, which the front and side firing LF driver arrangement maintains seamlessly down to the lowest frequencies produced. Expanding flexibility for applications where ArrayProcessing is not required, the KSLi12 includes the option to link two cabinets in Arc/Line modes. The cabinets are constructed from marine plywood and have an impact and weather protected PCP (Polyurea Cabinet Protection) finish. The front and side panels incorporate rigid metal grills backed by an acoustically transparent and water repellent fabric.

System data

Frequency response (-5 dB standard) 54 Hz - 18 kHz
 Frequency response (-5 dB CUT mode) 75 Hz - 18 kHz
 Max. sound pressure (1 m, free field)
 with 40D 144 dB¹

Loudspeaker data

Nominal impedance front LF 8 ohms
 Nominal impedance side LF/MF/HF 8 ohms
 Power handling capacity front LF (RMS/peak 10 ms) 450/1800 W
 Power handling capacity side LF/MF/HF (RMS/peak 10 ms)
 250/1000 W
 Nominal dispersion angle (horizontal) 120°
 Splay angle settings 0 - 10° (1° increment)
 Components 2 x 10" front LF driver
 2 x 8" side LF driver
 1 x 8" MF driver
 2 x 1.4" exit compression driver with 3" voice coil
 Passive crossover network
 Connections NLT4 F/M
 Phoenix socket
 Weight 57 kg (126 lb)

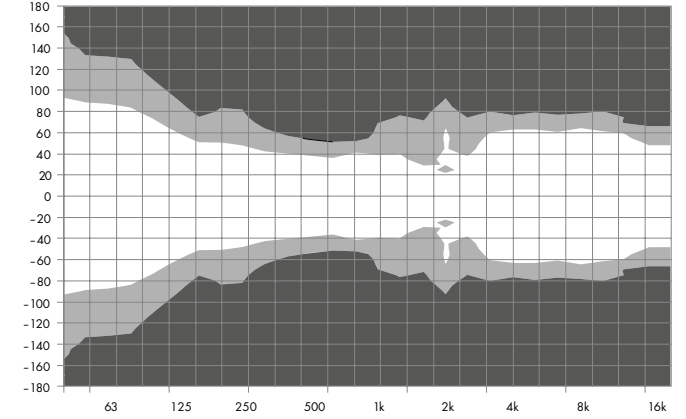

KSLi12 horizontal dispersion characteristics²

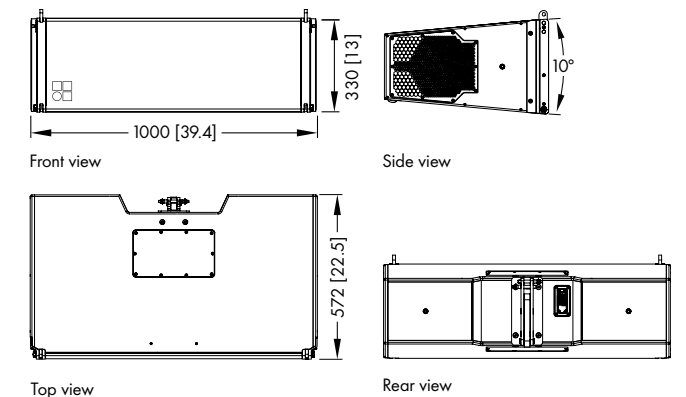

KSLi12 cabinet dimensions in mm [inch]

¹ SPLmax: Broadband signal IEC 60268
² Dispersion angle vs frequency plotted using lines of equal sound pressure (isobars) at -6 dB and -12 dB

The KSLi-SUB and KSLi-GSUB

KSLi-SUB and KSLi-GSUB

The KSLi-SUB and KSLi-GSUB are cardioid subwoofers to compliment the KSLi8 and KSLi12 loudspeakers. The KSLi-SUB rigging hardware allows columns of up to 16 cabinets to be flown while the KSLi-GSUB is intended for ground stacked applications only. Both subwoofers are actively driven, 2-way bass-reflex designs housing three long excursion 15" neodymium drivers. Two drivers face to the front while one radiates to the rear. The front and rear facing drivers operate in independent bass reflex chambers and are driven from separate amplifier channels. The cardioid dispersion pattern reduces unwanted energy behind the system, resulting in less excitation of the reverberant field to deliver highly accurate low frequency reproduction. The frequency response extends from 36 to 105 Hz/33 to 75 Hz. The KSLi-SUB cabinet incorporates front rear rigging strands while the KSLi-GSUB has no rigging components and is intended for ground stack purposes. The cabinets are constructed from marine plywood with an impact and weather protected PCP (Polyurea Cabinet Protection) finish. The front and rear of the subwoofers are protected by rigid metal grills backed by an acoustically transparent and water repellent fabric.

System data

Frequency response (-5 dB standard)36 Hz - 105 Hz
 Frequency response (-5 dB INFRA mode) 33 Hz - 75 Hz
 Max. sound pressure (1 m, free field).....
 with 40D 139 dB¹

Loudspeaker data

Nominal impedance front/rear 4/8 ohms
 Power handling capacity front (RMS/peak 10 ms)..... 900/3500
 Power handling capacity rear (RMS/peak 10 ms) .500/2000 W
 Components 3 x 15" driver
 Connections..... NLT4 F
 Phoenix socket
 Weight KSLi-SUB 82 kg (181 lb)
 Weight KSLi-GSUB 78 kg (172 lb)

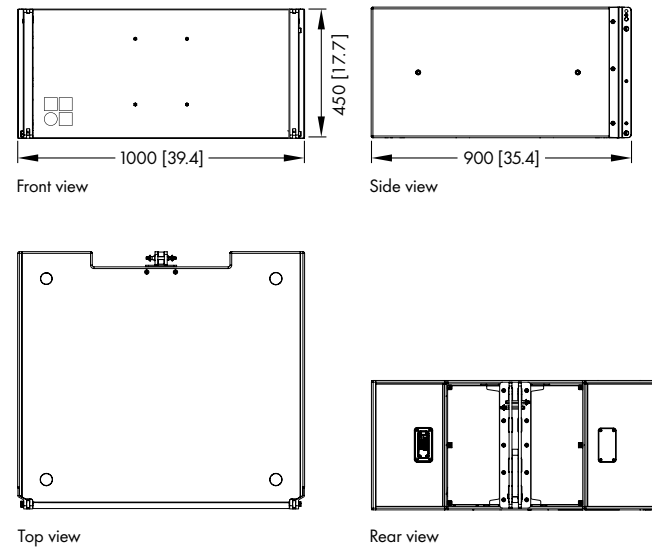

KSLi-SUB/KSLi-GSUB cabinet dimensions in mm [inch]

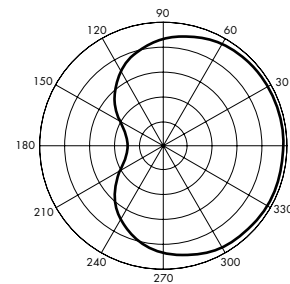

Cardioid polar pattern

The KSLi Weather Resistant, Special Colour and Custom solutions options

Weather Resistant (WR)

The WR option provides an IP54 rating, and enables operation of loudspeakers in changing ambient conditions, with some loudspeakers able to achieve an IP55 rating. However it is not intended to enable permanent, unprotected operation of loudspeakers outdoors. Cabinets used outdoors even with the WR option should always be aimed either horizontally or with a downward tilt. All WR speakers will be delivered without a cable.

Special Colour (SC) option

The paint finish of all loudspeaker cabinets and most accessories can be executed in almost any custom colour in accordance with common colour tables. All rigging fittings at the rear of the cabinet, Front links and Locking pins remain in black. Other paint finishes such as metallic are available on request. The acoustically transparent foam fitted behind the rigid metal grill is also painted with the requested special colour.

Custom solutions (SVS and SWR) option

SVS (Variants For Stadiums) loudspeakers have no integral rigging components, but instead, have threaded inserts in their side panels. The cabinets will be mechanically supported by metal brackets specifically designed for the respective application by Custom solutions.
 SWR (Sea Water Resistant) loudspeaker models are based on WR or SVS variants where available, and withstand outdoor operation in wet and acid or salty environments like on cruise ships or coastal locations. Other custom solutions are available upon request.

The KSLi rigging system

The KSLi rigging examples

Safety approval

d&b loudspeakers and accessories are designed for setup and use within situations requiring compliance with the provisions and directives of the DGUV regulation 17 (formerly BGV C1).

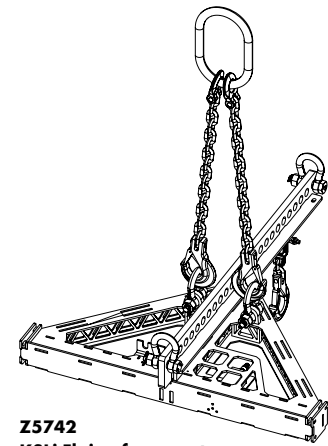

Z5742
KSLi Flying frame set

Flying frame set consists of:

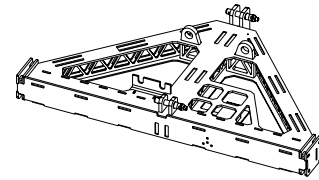

Z5740
KSLi Flying frame

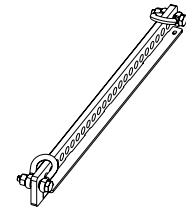

Z5741
KSLi Load beam



Z5705
Safety chain 4t

Single accessories:

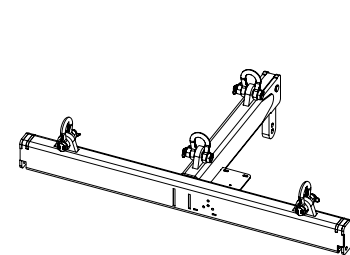

Z5743
KSLi-TOP Mounting frame

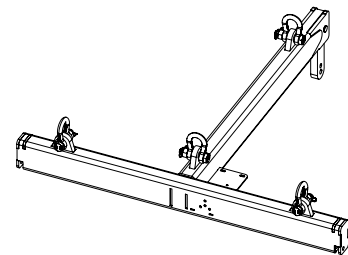

Z5744
KSLi-SUB Mounting frame

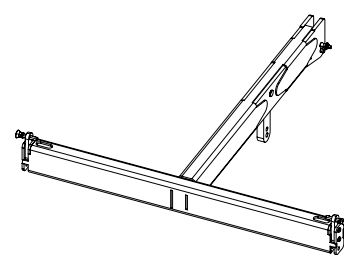

Z5745
KSLi-SUB Mounting adapter

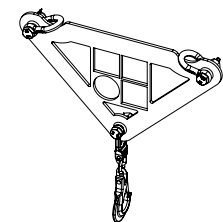

Z5707
SL Aiming plate



Z5706
Hoist connector chain 4t

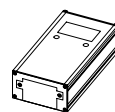

Z5762
ArraySight meter unit



Z5761
ArraySight sender unit

These rigging examples are for illustration only. For further information please refer to the TI 385 d&b Line array design as well as the SL-Series Rigging manual, both of which are available for download at www.dbaudio.com.

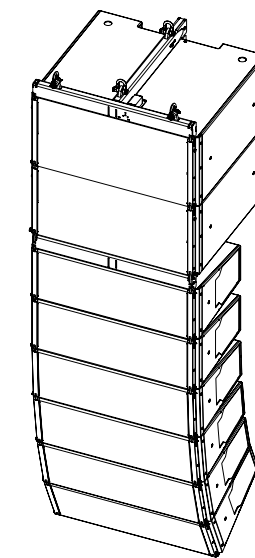

KSLi-SUB/ KSLi8/12
Mixed array - Front

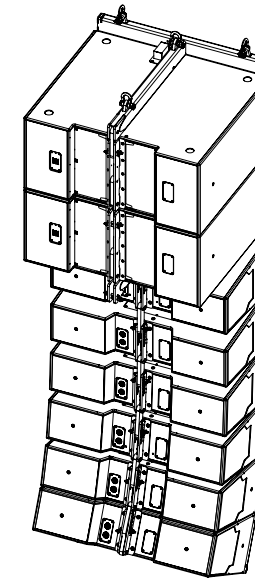

KSLi-SUB/ KSLi8/12
Mixed array - Rear

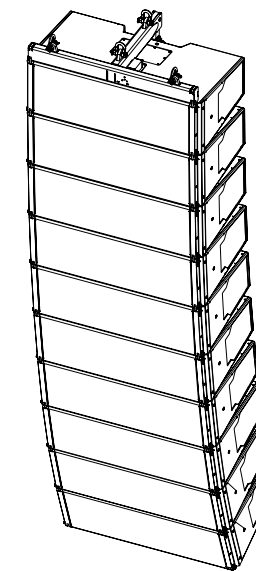

KSLi8/12 Line array
10-deep - Front

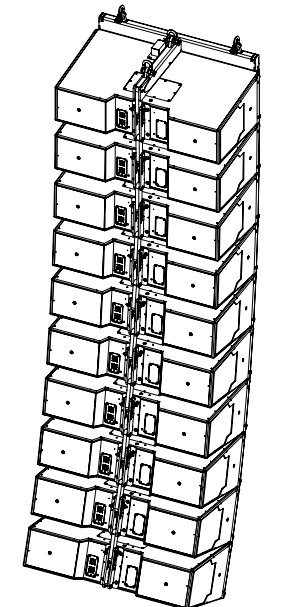

KSLi8/12 Line array
10-deep - Rear

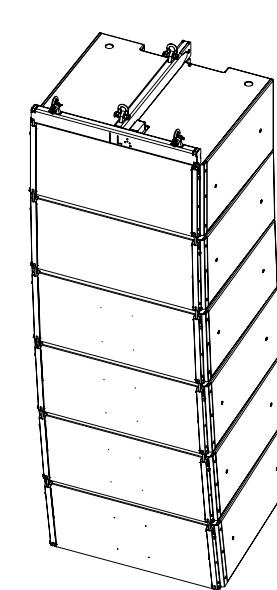

KSLi-SUB column 6-deep,
2° splay - Front

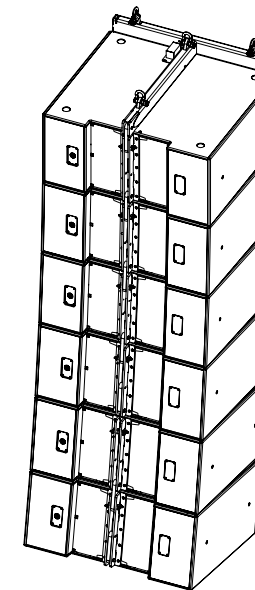

KSLi-SUB column 6-deep,
2° splay - Rear

The d&b ArrayCalc simulation software

The d&b ArrayCalc simulation software is the prediction tool for d&b line arrays, column and point source loudspeakers as well as subwoofers. This is a comprehensive toolbox for all tasks associated with acoustic design, performance prediction, alignment, rigging and safety parameters. For safety reasons d&b line arrays must be designed using the d&b ArrayCalc simulation software. ArrayCalc is available as a native stand-alone application for both Microsoft Windows¹ (Win7 64-bit or later) and Mac OS X² (10.12 or later) operating systems. In combination with the d&b Remote Network, this can significantly reduce setup and tuning time in mobile applications and allows for precise simulations when planning installations. Listening planes can be defined in the venue tab, creating a three dimensional representation of any audience area in a given venue. This can also include balconies, side stalls, arenas, in the round scenarios or festivals. Special functions assist in obtaining accurate dimensions with laser distance finders and inclinometers.

Simulation

Up to forty flown arrays or subwoofer columns can be defined in a project file as single hangs or in pairs. A selection of d&b point source loudspeakers can also be fully integrated as well as a ground stacked SUB array consisting of up to eighty positions. All can be freely positioned according to their intended application, for example as main hang, outfill, nearfill or delay. Position, orientation, aiming and coverage details are displayed. Level over distance is calculated for each source with high resolution in real time, for either band limited or broadband input signals. The comprehensive simulation precisely models the actual performance of the system, taking into account input level, all system configuration options (such as CUT, CPL, HFC or INFRA), limiter headroom and air absorption. Acoustic obstacles, such as video screens, can be added to a model. Acoustic shadowing, whether by these obstacles, or a balcony overhang, is taken into consideration. The load status of all array rigging components is calculated accurately and displayed to determine whether a given array is within the load tolerance. Subwoofer array design is assisted by coverage and polar plot prediction. A specialized algorithm allows the user to specify subwoofer positions and a coverage angle, which is then converted into appropriate delay settings that result in the desired dispersion. The alignment tab enables different sources to be time aligned to one another, as well as showing arrival times and Sound Pressure Levels at a definable reference point on one of the audience areas. For alignment of the flown system with the ground stacked SUB array, the phase response of both the SUB array and a flown source is calculated at a definable reference point.

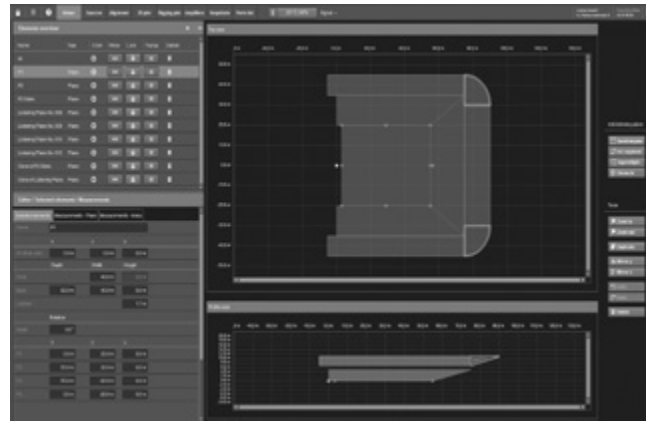

Venue

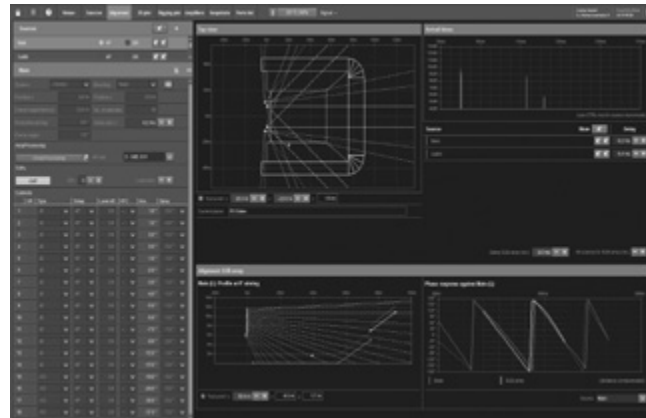

Alignment

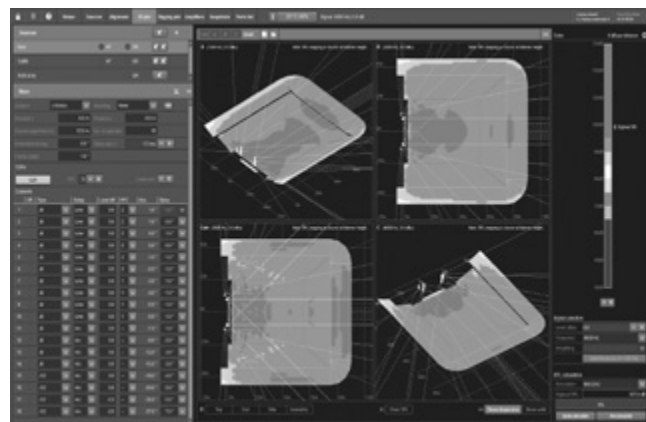

3D Plot quad

Both simulations reflect changes in delay time to the single sources in real time. The d&b ArrayCalc simulation software is available at www.dbaudio.com.

Prediction

The level distribution resulting from the interaction of all active sources can be mapped onto the audience areas in a three-dimensional view, which can also be zoomed, rotated and exported as a graphics file. EASE and DXF data export capabilities are also available. A rigging plot with all necessary coordinates, dimensions and weights of arrays is generated for export and printing and a parts list, detailing all components required. The d&b ArrayCalc Viewer app presents this key information for positioning and flying a d&b audiotechnik loudspeaker system on a mobile device. Once the system has been designed, calculated and optimized, all relevant project information can be shared via email, AirDrop, or downloaded onto any iOS or Android device.

ArrayProcessing

The optional ArrayProcessing function applies powerful filter algorithms to optimize the tonal (spectral) and level (spatial) performance of a line array column over the audience area defined by its mechanical vertical coverage angle. Temperature and Humidity Control (THC) for ArrayProcessing introduces a workflow that permits a system to adapt to changing atmospheric conditions in real time via R1. Within the d&b ArrayCalc simulation software, spectral and level performance targets over the listening areas can be defined while specific level drops or offsets can be applied to certain areas, to assign reduced level zones. ArrayProcessing applies a combination of FIR and IIR filters to each individual cabinet in an array to achieve the targeted performance, with an additional latency of only 5.9 ms. This significantly improves the linearity of the response over distance as well as seamlessly correcting for air absorption. In addition, ArrayProcessing employs the same frequency response targets for all d&b line arrays, to ensure all systems share a common coverage is enhanced with spectral consistency and defined level distribution, achieving more linear dispersion and total system directivity to cover longer distances or steep listening areas effectively.

R1 Remote Control Software

R1 uses the same project file created by ArrayCalc and generates an intuitive graphical user interface including complete details of the simulated system, loudspeakers, amplifiers, remote IDs, groups, ArrayProcessing data and all configuration information. This workflow removes the need to manually transfer data from one software program to the other.

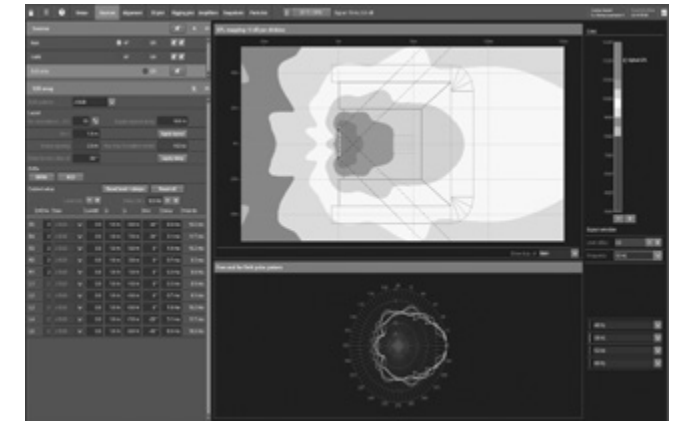

Sources, SUB array

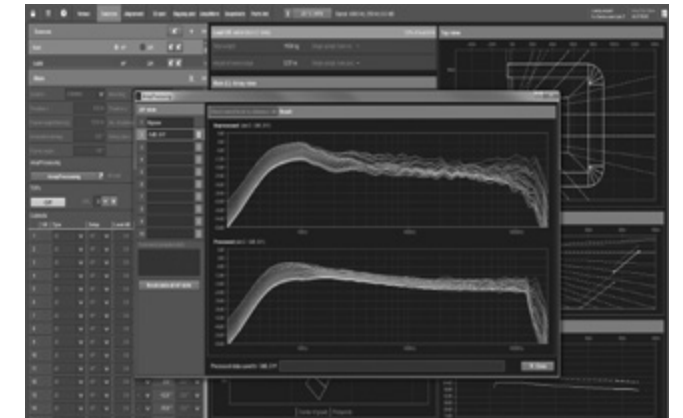

ArrayProcessing

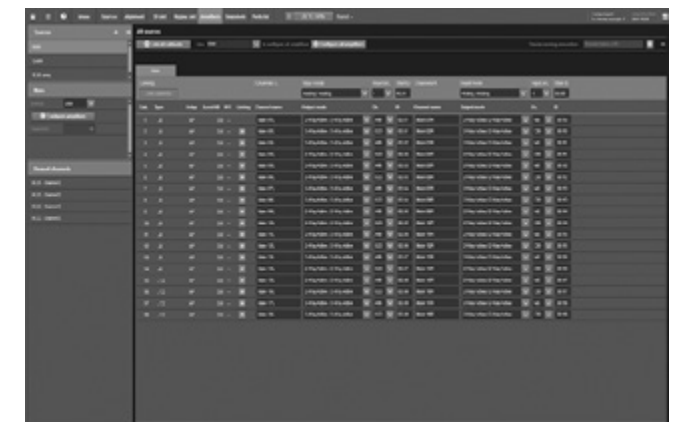

Amplifiers

¹ Microsoft Windows is a registered trademark or trademark of Microsoft Corporation in the United States and/or other countries

² Mac OS X is a trademark of Apple Inc., registered in the U.S. and other countries

The d&b NoizCalc immission modelling software

The d&b software uses international standards to model the far field noise immission from multiple complex and coherently emitting sources such as line arrays and subwoofer arrays. More and more, gaining permission and licenses to stage live open air events requires an official statement with a prediction of how noise could impact on the surrounding area. NoizCalc takes all complex loudspeaker data and a reference point from the d&b ArrayCalc simulation software and calculates the sound propagation and relative attenuation values towards the far field for a certain scenario with particular meteorological conditions for one or more d&b loudspeaker systems.

A 3D terrain map imported from Google Maps or Street View displays the calculated immission on the areas surrounding the audience listening zones. This visual representation shows the actual system performance in the far field, enabling users to optimize for listeners while satisfying local noise restrictions and offsite regulations.

To ensure reliable results, NoizCalc includes all complex data concerning the addition and subtraction of sound waves, including phase information to describe the combination and interaction effects within a loudspeaker system consisting of multiple line arrays, subwoofer arrays and delay systems.

NoizCalc models immissions in the far field according to the internationally accepted ISO 9613-2 or Nord2000 calculation standards. Ground characteristics can be set depending on the absorbency or reflectivity of surfaces, while areas with volume attenuating properties can be defined. Buildings can be included, and the maximum reflection order option adjusts how many reflections are calculated. Parameters for humidity, air pressure and temperature ensure that the correct air absorption figures are accounted. The ISO 9613-2 standard requires limited meteorological information and assumes a worst-case scenario. The more sophisticated propagation model, Nord2000 enables a more precise handling of meteorological conditions allowing the user to model with prevailing wind information. The d&b NoizCalc immission modelling software is available at www.dbaudio.com for registered download, along with further information and video tutorials. It was developed in collaboration with SoundPLAN, a specialist software developer for environmental noise prediction.

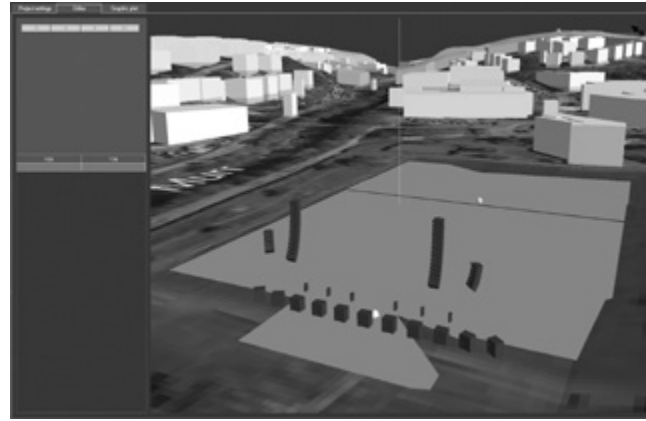

Editor



Graphic plot

The d&b R1 Remote control software

The remote control capability of the d&b Remote Network enables central control and monitoring of a complete d&b loudspeaker system from anywhere in the network, be it from a computer in the control room, at the mix position, or on a wireless tablet in the auditorium. This central access to all functions throughout the d&b Remote Network unlocks the full potential of the d&b system approach. In a typical user workflow, the d&b Remote Network takes settings optimized in the d&b ArrayCalc simulation software and applies these to all the amplifiers within the network.

All functions and controls available on the front panel of d&b amplifiers may be remotely controlled and/or monitored using the d&b R1 Remote control software. This allows each channel of the amplifier to be controlled and enables the creation of groups of loudspeakers. When grouped together, a button or fader can control the overall system level, zone level, equalization and delay, power ON/OFF, MUTE, as well as loudspeaker specific function switches such as CUT/HFA/HFC and CPL. An offline mode is provided for preparation in advance of an event, without the amplifiers being present or connected.

d&b System check verifies that the system performs within a predefined condition, while the Array verification function automatically identifies the physical position of a loudspeaker in an array to check that the system is cabled correctly. Extensive facilities for storing and recalling system settings are provided allowing these to be repeated, as and when required. For mobile applications, project files can be easily adjusted for use with a different set of equipment at another location.

The R1 software is optimized for use with touch screen, mouse and keyboard and runs on both Microsoft Windows¹ (Win7 64-bit or later) and Mac OS X² (10.12 or later).

Further information is provided in the d&b Amplifier and Software brochure which is available for download at www.dbaudio.com.



R1 home screen



R1 in configuration mode



D20/D80 16-band equalizer in R1

¹ Microsoft Windows is a registered trademark or trademark of Microsoft Corporation in the United States and/or other countries

² Mac OS X is a trademark of Apple Inc., registered in the U.S. and other countries

The DS10 and DS20 Audio network bridges

The DS100 Signal Engine

DS10 Audio network bridge

The DS10 Audio network bridge interfaces between Dante networks and AES3 digital audio signals, while also providing distribution of Ethernet control data. Positioned within the signal chain in front of the amplifiers, this 1 RU device expands the d&b system approach. Each unit can deliver up to sixteen Dante network channels via AES3 digital signal outputs. Additionally, four AES3 input channels provide access to the Dante audio network for applications such as a break-in from a Front of House console. The DS10 incorporates an integrated 5-port switch, offering a primary and redundant network for the Dante protocol, as well as advanced functions such as Multicast Filtering and VLAN modes. Using the DS10 Audio network bridge, audio signals and remote control data can be combined using a single Ethernet cable.



The DS10 Audio network bridge front view



The DS10 Audio network bridge rear view

DS20 Audio network bridge

The DS20 Audio network bridge supports the open standards-based Milan protocol rather than Dante. Milan (Media integrated local area networking) is a high level interoperability solution based on Audio Video Bridging (AVB) technology. The main advantages are deterministic behaviour (zero network congestion); improved reliability; optimum synchronization and hassle free network setup, as no special settings, such as QoS, need to be set within the switches to ensure delivery.



The DS20 Audio network bridge front view



The DS20 Audio network bridge rear view

DS100 Signal Engine

The DS100 Signal Engine is the platform underneath the Soundscape, based on a specialized rack mount 3 RU audio processor with Audinate Dante networking. It provides a 64 x 64 audio matrix with level and delay adjustments at all cross points. Additional software modules provide dynamic source positioning and emulated acoustics functions. The DS100 is a versatile tool for use within complex audio systems to route and distribute multiple audio channels to numerous amplifiers driving loudspeaker positions and zones, show relay and break out rooms. The networking capabilities with a Dante enabled processor are significant, particularly for busy, multi-room complexes. The DS100 completely integrates with the overall d&b system approach, including loudspeakers, amplifiers, rigging, transport and networking accessories and the DS10 Audio network bridge. The complete system is designed and optimized in the d&b ArrayCalc simulation software, and controlled via the d&b R1 Remote control software.



The DS100 Signal Engine front view

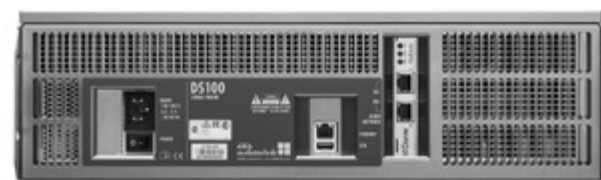

The DS100 Signal Engine rear view

40D amplifier

The 2 RU 40D high performance amplifier provides the power density required for installation purposes while the powerful signal processing extends the level of functionality of the on-board features. The user interface of the amplifier consists a 4.3" color touchscreen providing comprehensive information of the device configuration and enhanced status monitoring. The user definable equalizer features two independent 16-band EQ groups within each channel. These provide parametric, notch, shelving and asymmetric filters as well as a graphic EQ (via the d&b R1 Remote control software). The delay capability covers a range of up to 10 s. All loudspeaker specific functions such as CUT, HFA, HFC, THC or CPL are available. Up to eight opto-coupled GPI pins (General Purpose Input) and up to four

GPO pins (General Purpose Output) are available on Phoenix Euroblock connectors as additional digital control lines. This enables external control and detection functions. An additional 3-pin Phoenix Euroblock fault contact is provided allowing a general device error to be remotely indicated. For applicable loudspeakers, d&b LoadMatch enables the 40D amplifier to electrically compensate for the properties of the cable used. The 40D utilizes a switch mode power supply with active Power Factor Correction (PFC) to produce a clean current draw and ensure stable and efficient performance under adverse mains conditions. The high power capabilities provide increased power to fully drive all applicable d&b loudspeaker cabinets and sufficient headroom for any future systems.

	40D
User interface	Colour TFT touchscreen
Output channels	4
Input channels	4 x AES3 and 4 x analog
Latency	0.3 msec
User equalizers (per channel)	2 x 16-band
Delay	10 sec/3440 m
Maximum output power	4 x 2000 W into 8 ohms 4 x 2000 W into 4 ohms
Output routing	Dual Channel, Mix TOP/SUB 2-Way Active
Output connectors	Phoenix Euroblock
Cable compensation	LoadMatch
Power supply	Autosensing switched mode power supply with active PFC
Mains voltage	100 - 127/208 - 240 V, 50 - 60 Hz
Weight (kg/lb)	13.3/29.3
Dimensions	2 RU x 19" x 465 mm
Remote	OCA/AES70 via Ethernet



40D amplifier

Airflow

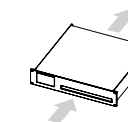

The controller setups and operation with 40D amplifier

Arc and Line setup

The Arc mode is used for line array loudspeakers when used in curved array sections with splay angles between 2° and 7°. The Line mode is used for long throw array sections with three or more consecutive splay settings between 0° and 1°. Compared to the Arc mode, the upper mid range is reduced to compensate for the extended near field.

AP setup

In connection with ArrayProcessing (AP), the AP setup contains the AP data that are generated in the ArrayCalc simulation software. These are transferred to the applicable amplifiers via the d&b Remote network (OCA/AES70) using R1.

CUT mode

Set to CUT, the cabinet low frequency level is reduced and it is now configured for use with the d&b SL subwoofer.

HFC mode

Selecting the HFC (High Frequency Compensation) mode compensates for loss of high frequency energy due to absorption in air when loudspeakers are used to cover far field listening positions. HFC has two settings which should be used selectively, HFC1 for cabinets covering distances larger than 40 m (130 ft) and HFC2 for those covering distances larger than 80 m (260 ft). This can be used to achieve the correct sound balance between close and remote audience areas allowing all amplifiers driving the array to be fed from the same signal source. Thus the whole array performs with comparable headroom.

CPL function

The CPL (Coupling) function compensates for coupling effects between closely coupled cabinets by reducing the low and mid frequency level. SL-Series CPL has been enhanced and allows independent shaping of low and low-mid frequency responses using a dual-stage filter. This enables full use of the extended SL-Series LF headroom. The classic CPL function remains for J-, V-, Y- and T-Series arrays, and uses a single low shelving-like filter response.

INFRA mode

With the INFRA mode selected, the frequency response of the system extends from 33 Hz to 75 Hz. The KSLi-SUB/KSLi-GSUB can now be used to supplement applicable d&b loudspeaker systems operated in full range mode.

Maximum loudspeakers per amplifier

	KSLi8	KSLi12	KSLi-SUB	KSLi-GSUB
40D ¹	2	2	2	2
40D	4	4	2	2

Available controller settings

	KSLi8	KSLi12	KSLi-SUB	KSLi-GSUB
Arc/Line	x	x		
AP	x	x	x	
CUT	x	x		
HFC	x	x		
CPL	x	x		
INFRA			x	x

The KSLi System frequency responses

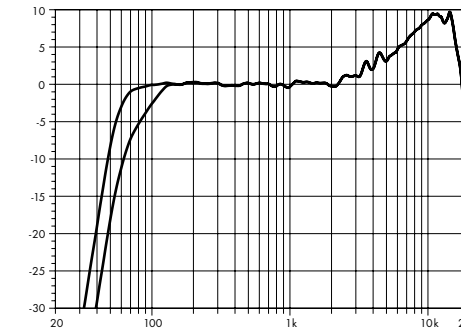

KSLi8 frequency response, standard and CUT modes¹

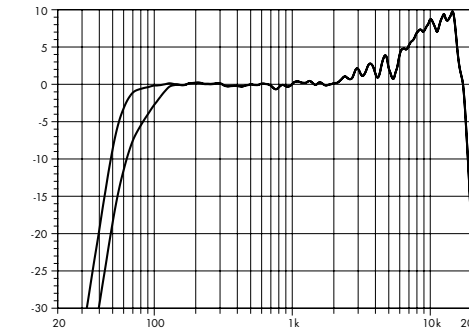

KSLi12 frequency response, standard and CUT modes¹

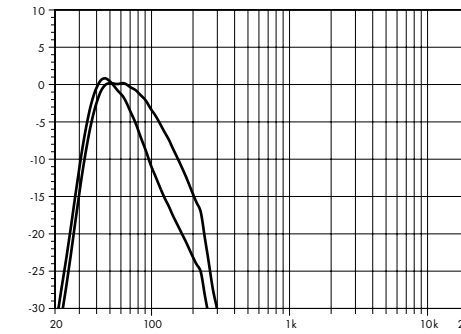

KSLi-SUB/KSLi-GSUB frequency response, standard and INFRA modes

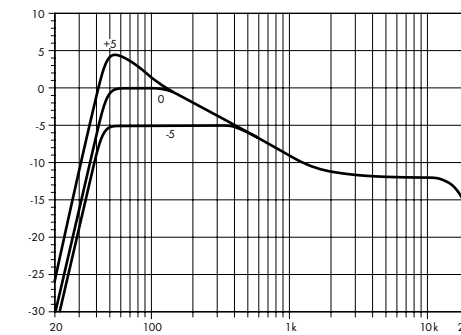

SL-CPL Low²

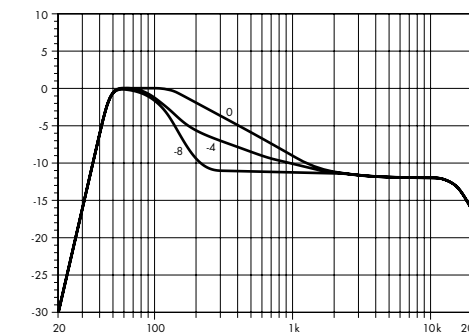

SL-CPL Mid²

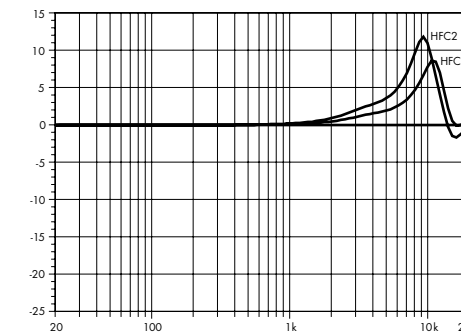

Correction of HFC²

The KSLi System configuration examples

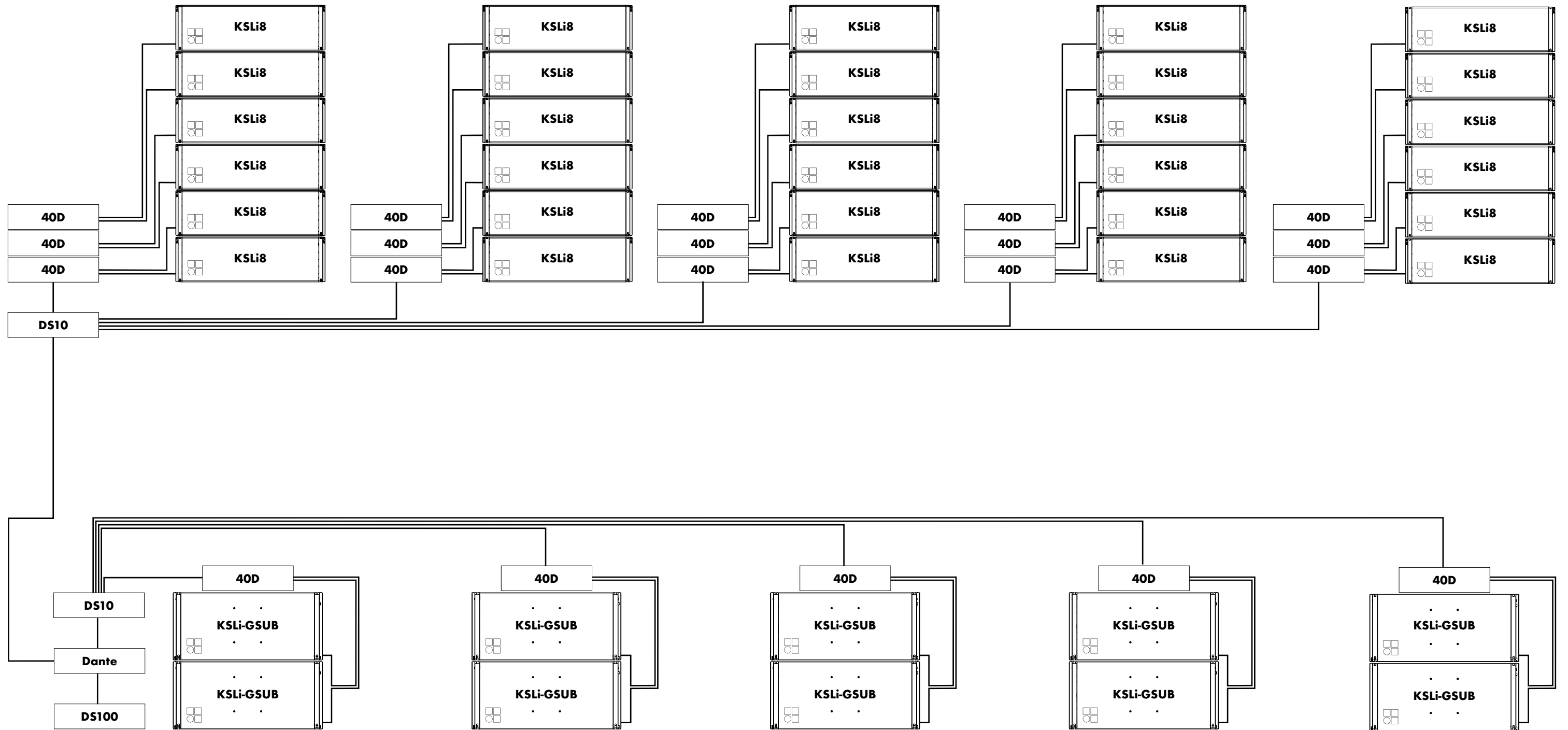

KSLi Soundscape configuration comprising 5 x KSLi8 Arrays, each powered with 3 x 40D amplifier and 5 x ground stacked KSLi-GSUBs, each powered with a 40D amplifier. Signal distribution via Dante network with a DS100 Signal Engine and two DS10 Audio network bridges

The KSLi System configuration examples

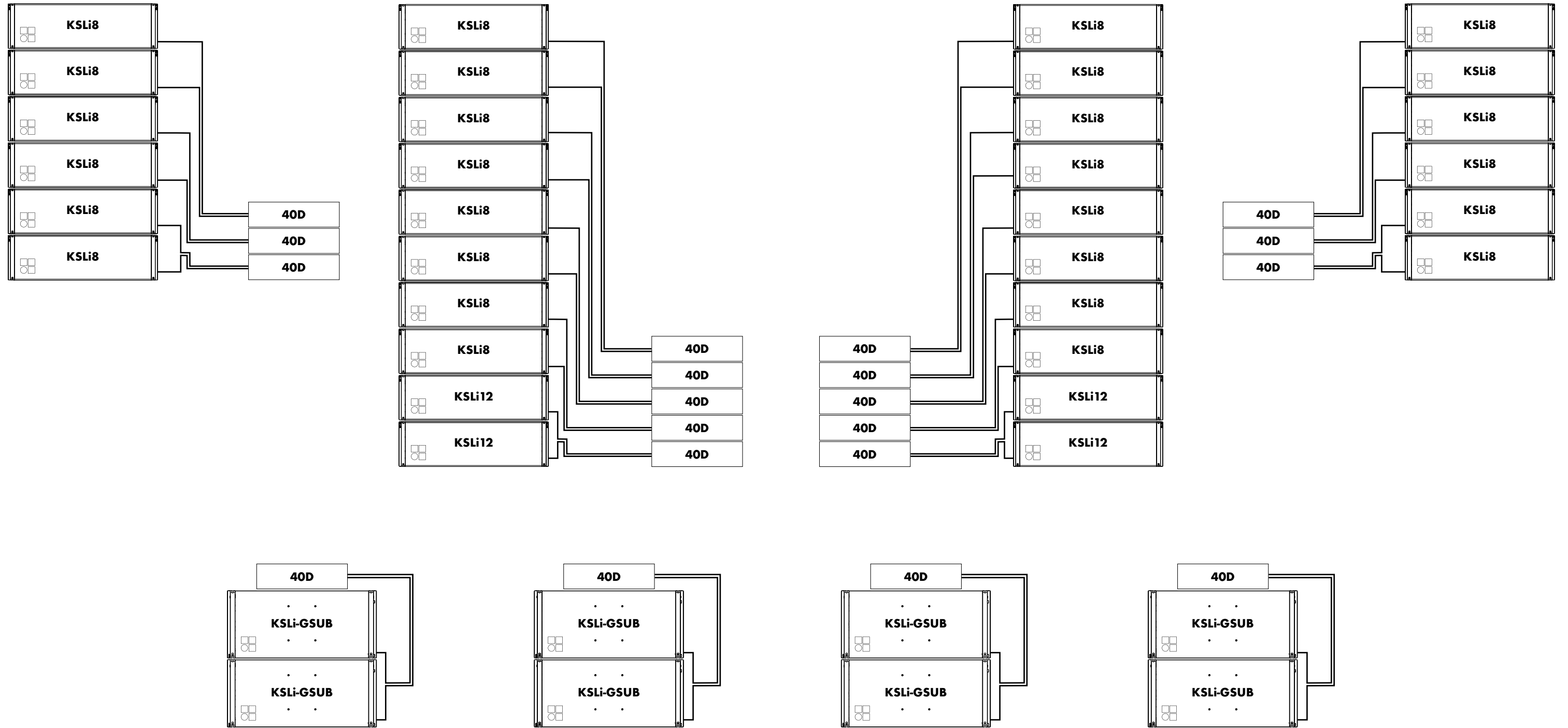

KSLi House of Worship configuration comprising KSLi8/12 mains and KSLi8 side fills along with 4 x ground stacked KSLi-GSUBs with 40D amplifiers

The KSLi System configuration examples

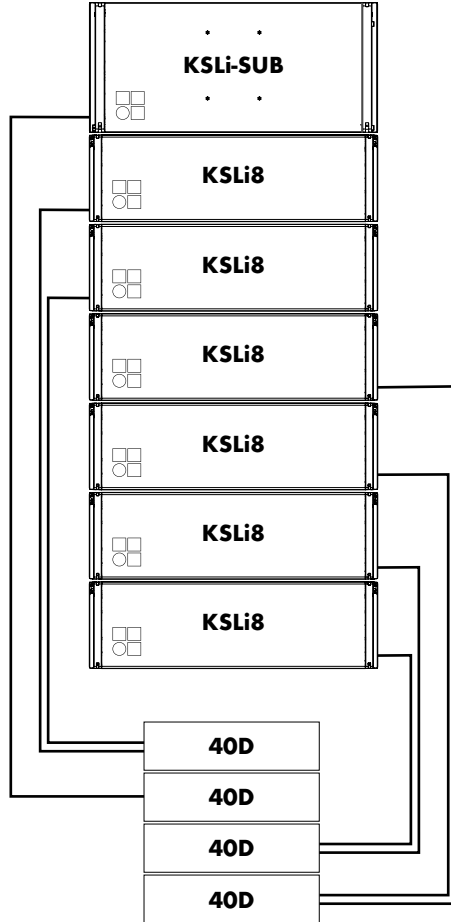
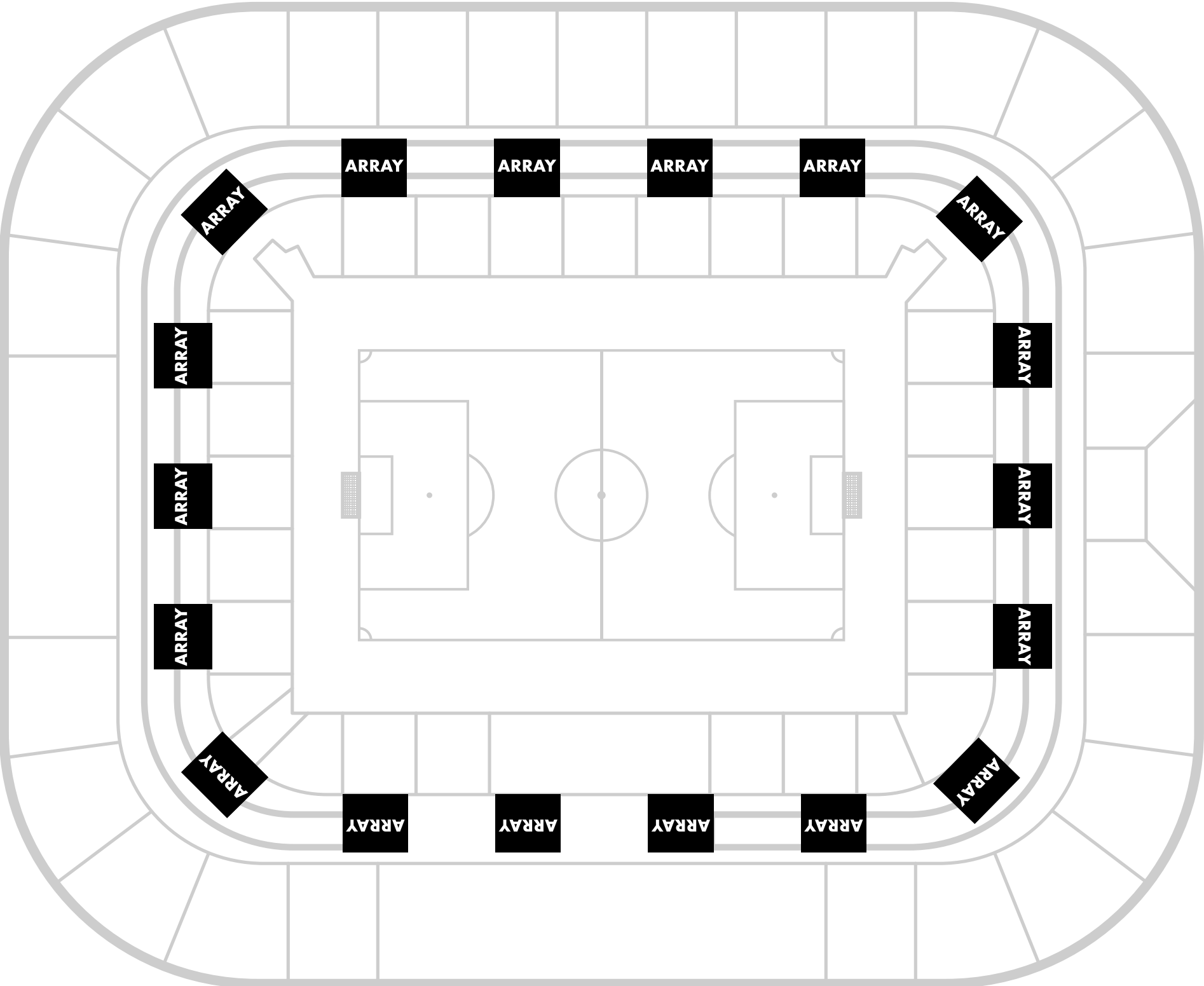

KSLi Stadium configuration comprising 18 x KSLi-SUB/KSLi8 mixed arrays in SVS, each powered by 4 x 40D amplifiers

The KSLi System product overview

KSLi loudspeakers	Z0790.000	KSLi8 Loudspeaker¹
	Z0790.100	KSLi8 Loudspeaker WR
	Z0790.901	KSLi8 Loudspeaker SC
	Z0791.000	KSLi12 Loudspeaker¹
	Z0791.100	KSLi12 Loudspeaker WR
	Z0791.901	KSLi12 Loudspeaker SC
	Z0795.000	KSLi-SUB¹
	Z0795.100	KSLi-SUB WR
	Z0795.901	KSLi-SUB SC
	Z0796.000	KSLi-GSUB¹
	Z0796.100	KSLi-GSUB WR
	Z0796.901	KSLi-GSUB SC
	KSLi accessories	Z5742.000
Z5742.901		KSLi Flying frame set SC
Z5743.000		KSLi-TOP mounting frame
Z5743.901		KSLi-TOP mounting frame SC
Z5744.000		KSLi-SUB mounting frame
Z5744.901		KSLi-SUB mounting frame SC
Z5745.000		KSLi-SUB mounting adapter
Processing and distribution	Z4010.000	DS10 Audio network bridge
	Z4011.000	DS20 Audio network bridge
	Z4100.000	DS100 Signal Engine
Amplifiers	Z2830.xxx	40D Amplifier²
	Z2623.000	Accessory kit for 40D Phoenix Euroblock connectors
Cables	K3111.000	MC4 SD LS-Multicore 4x4 + 2x0,5
	K3112.000	MC4 SWR LS-Multicore 4x4

¹ SVS and SWR on request

² The complete list of installation amplifier versions is available in the d&b xD Installation Amplifier and Software brochure

