

V

Vi
Rigging manual
1.4 en

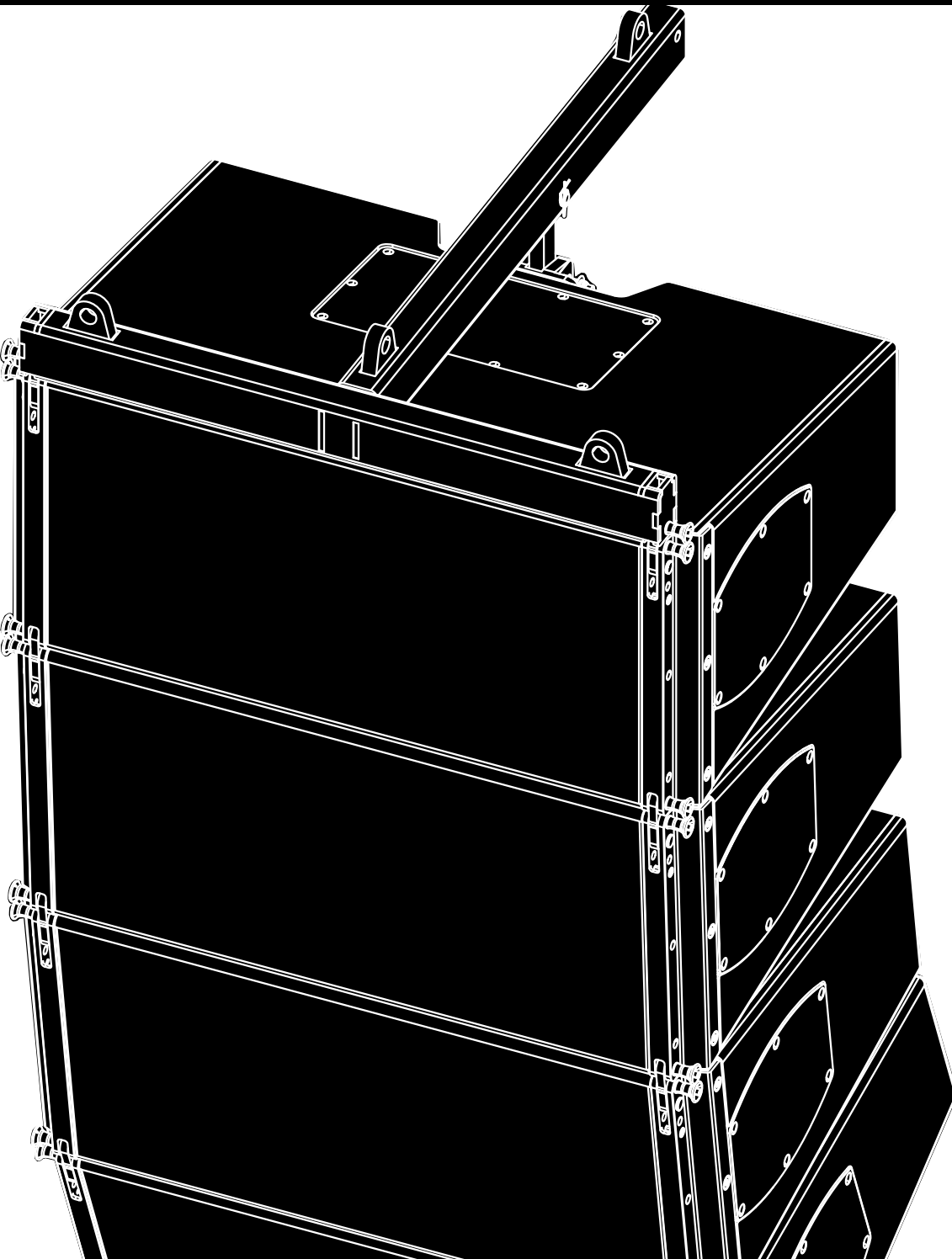

General information

Vi Rigging manual

Version: 1.4 en, 05/2022, D2708.EN .01

Copyright © 2022 by d&b audiotechnik GmbH & Co. KG; all rights reserved.

Keep this document with the product or in a safe place so that it is available for future reference.

We recommend you to regularly check the d&b website for the latest version of this document.

When reselling this product, hand over this document to the new owner.

If you supply d&b products, please draw the attention of your customers to this document. Enclose the relevant documents with the systems. If you require additional documents for this purpose, you can order them from d&b.

d&b audiotechnik GmbH & Co. KG
Eugen-Adolff-Str. 134, D-71522 Backnang, Germany
T +49-7191-9669-0, F +49-7191-95 00 00
docadmin@dbaudio.com, www.dbaudio.com

1 Safety	4
1.1 Intended use.....	4
1.2 General safety.....	4
1.3 Load capacity/System safety.....	4
1.3.1 Wind loads.....	5
1.4 Secondary safety.....	5
1.5 Operational safety.....	5
1.6 d&b ArrayCalc simulation software / TI 385.....	6
2 Rigging concept and components	7
2.1 Mounting and flying frames.....	7
2.1.1 Z5387.000 Vi Mounting frame top.....	8
2.1.2 Z5387.001 Vi Mounting frame bottom.....	9
2.1.3 Dimensional drawings.....	10
2.2 Ring cotters.....	11
2.3 Locking pins.....	12
2.4 Rear/Splay links of the frames.....	12
2.5 Cabinet's rigging mechanism.....	15
2.5.1 Front link mechanism.....	15
2.5.2 Splay/Rear link mechanism.....	16
2.5.3 Setting splay angles for Vi-TOP cabinets.....	16
3 Arrays and assembly	17
3.1 Setup preparation.....	18
3.2 Vi8/Vi12 Array.....	18
3.3 Vi-SUB Column.....	21
3.4 Mixed array.....	24
4 Safety and system checks	30
4.1 Mechanical setup.....	30
4.2 Wiring.....	30
5 Hoisting and aiming the array	31
5.1 Hoisting the array.....	31
5.2 Modifying the vertical aiming of the array.....	31
5.2.1 Dedicated fixing points.....	32
6 Care and maintenance / Disposal	33
6.1 Visual and functional inspection.....	33
6.2 Disposal.....	33
7 Manufacturer's declaration	34
7.1 EU conformity (CE symbol).....	34
7.2 Disposal.....	34

1.1 Intended use

The Vi rigging components must only be used in conjunction with d&b Vi loudspeakers as described in this manual.

1.2 General safety

- Installation and setup should only be carried out by qualified and authorized personnel observing the valid national Rules for the Prevention of Accidents (RPA).
- It is the responsibility of the person installing the assembly to ensure that the suspension/fixing points are suitable for the intended use.
- Always carry out a visual and functional inspection of the items before use. In case there is any doubt as to the proper functioning and safety of the items, these must be withdrawn from use immediately.

Please also refer to ⇒ Chapter 6 "Care and maintenance / Disposal" on page 33.

1.3 Load capacity/System safety

Z5387.000 Vi Mounting frame top

The Vi Mounting frame top is designed to suspend smaller arrays of Vi-TOP or Vi-SUB cabinets with a total system weight of up to 141 kg (311 lb) - SWL, which corresponds to a total weight of up to 4 x Vi-TOP cabinets.

For any other array configuration which exceeds the maximum permissible system weight for the Vi Mounting frame top, the Z5380 V Flying frame must be used.

Note: A detailed description of the Z5380 V Flying frame including the relevant assembly instructions is given in the V-Series Rigging manual, which is supplied with the V Flying frame.

Z5387.001 Vi Mounting frame bottom

The Z5387.001 Vi Mounting frame bottom is designed as a pullback device to fix and/or pull back an array with either the Z5387.000 Vi Mounting frame top or the Z5380 V Flying frame attached at the top of the array.

Alternatively, the frame can be used as an adapter frame to be mounted underneath SUB cabinets in mixed array configurations with the Z5380 V Flying frame on top of the array. In this case, the frame can support a total system weight of up to 141 kg (311 lb) - SWL, which corresponds to a total weight of up to 4 x Vi-TOP cabinets.

For any other array configuration which exceeds the maximum permissible system weight for the Vi Mounting frame bottom, the Z5380 V Flying frame must be used.

Note: A detailed description of the Z5380 V Flying frame including the relevant assembly instructions is given in the V-Series Rigging manual, which is supplied with the V Flying frame.

1.3.1 Wind loads

WARNING!
Potential risk of personal injury and material damage!

When setting up fixed outdoor installations, unpredictable wind loads must be taken into account.

The dedicated fixing points for the array assemblies described in this manual are detailed in ⇒ Chapter 5 "Hoisting and aiming the array" on page 31.

1.4 Secondary safety

WARNING!
Potential risk of personal injury and/or damage to material!

- The secondary safety suspension must be independent of the primary suspension points and capable of carrying the total system weight.
- The additional safety device must be mounted in a way that, if the primary suspension fails, the array is caught by the safety device without any drop or swing.

1.5 Operational safety

The assembly should always be carried out by two persons.

During assembly pay attention to the possible risk of crushing. Wear suitable protective clothing.

Observe all instructions given on the respective instruction labels of the rigging components (Flying frame, Load adapters), Touring carts and loudspeaker cabinets.

Observe all instructions given on the respective instruction labels of the rigging components and loudspeaker cabinets.

When chain hoists are in operation ensure that there is nobody directly underneath or in the vicinity of the load.

Do not under any circumstances climb on the array.



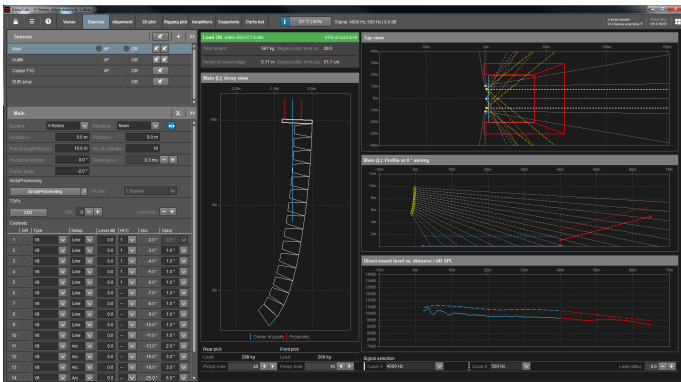

d&b ArrayCalc

1.6 d&b ArrayCalc simulation software / TI 385

For both safety and acoustic reasons, d&b line arrays must be designed using the d&b ArrayCalc simulation software. The software is available as a native stand-alone application for both Microsoft Windows and Mac OS X operating systems and can be downloaded at www.dbaudio.com.

Detailed information on how to use and operate ArrayCalc is provided by the Help system of the software. To access the Help system, press F1 or select the Help button () from the ArrayCalc toolbar. This will launch the HelpViewer which provides an overview of the program as well as a search function and direct access to the related topics.

In addition, ArrayCalc will provide you with typical array configurations within the permitted load limits and will help you get familiar with the mechanical load conditions and limitations.

Further information on line array design can be found in "TI 385 d&b Line array design, ArrayCalc". The TI is supplied with the software or can be downloaded from the d&b website at www.dbaudio.com.

We also recommend you to attend the regularly hosted d&b Line array training seminars. Further information regarding the d&b seminars and a seminar schedule can also be found on the d&b website at www.dbaudio.com.

2.1 Mounting and flying frames

The d&b Vi loudspeakers are supplemented by two mounting frames, the Z5387.xxx Vi Mounting frames, one for the top and one for the bottom of an array.

These frames allows the setup of the following array configurations:

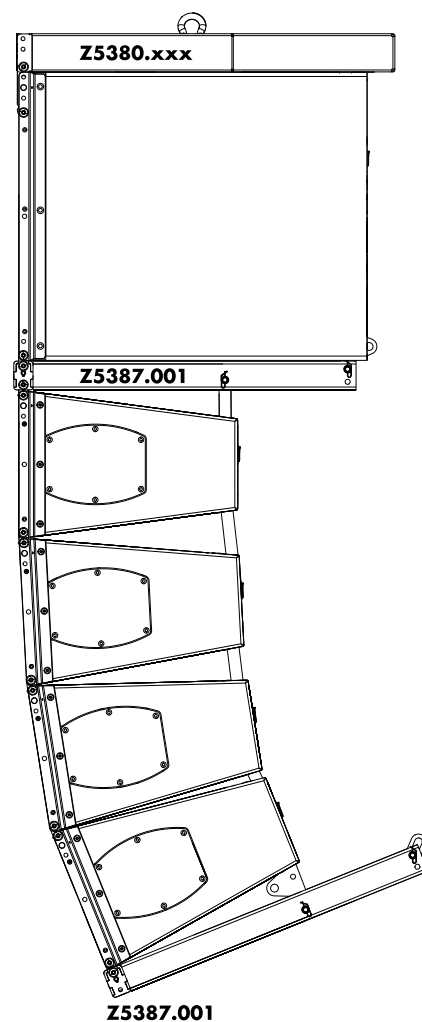
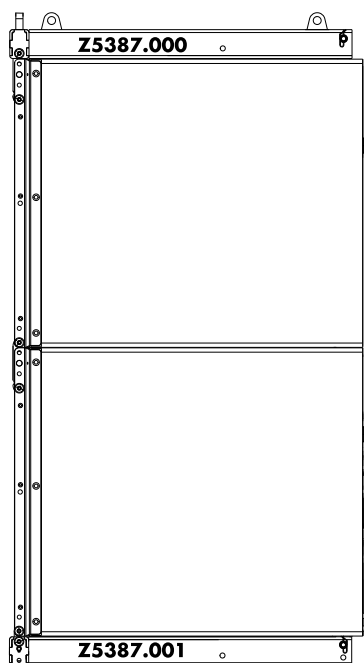
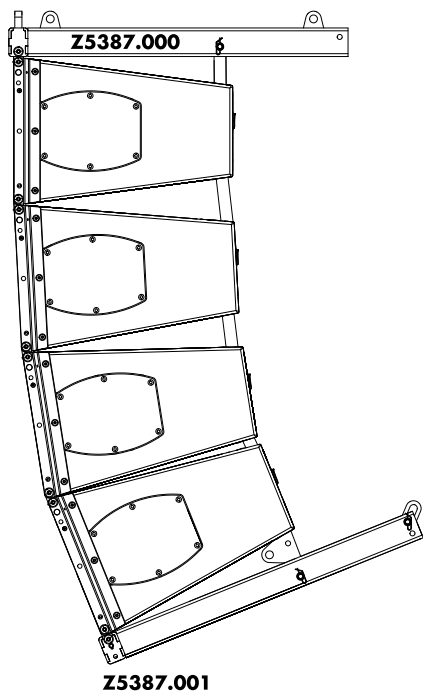

2.1.1 Z5387.000 Vi Mounting frame top

Intended use

The Z5387.000 Vi Mounting frame top is designed to support arrays with a maximum weight of up to 141 kg (311 lb), which corresponds to flown configurations of 4 x Vi-TOP or 2 x Vi-SUB cabinets.

Scope of supply

Please verify the shipment for completeness and proper condition of the items.

The Z5387.000 Vi Mounting frame top is equipped and supplied with the following rigging components.

Note: In delivered condition, the Rear/Splay links **[3A/B]** are not attached to the frame. For assembly instructions please refer to ⇒ Chapter 2.4 "Rear/Splay links of the frames" ⇒ Attaching the Splay/Rear links and the O-ring on page 13.

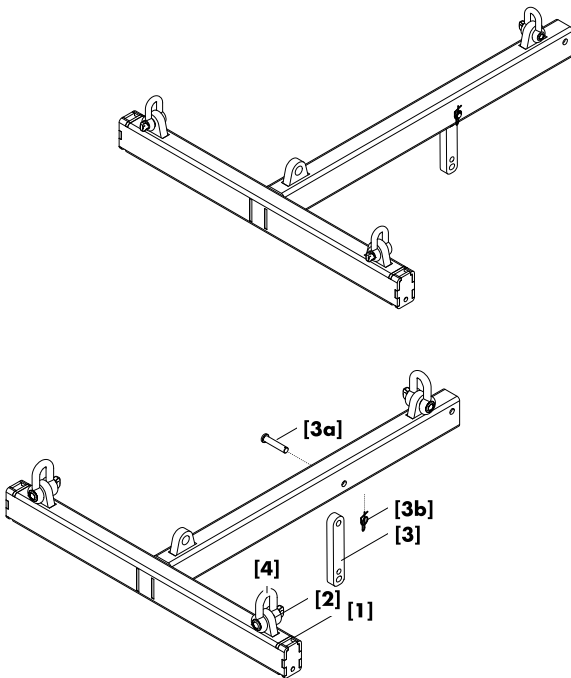

Pos.	Component	Description
[1]	Z5387.000 Vi Mounting frame top	Weight (including all rigging components): 11.1 kg (24.5 lb).
[2]	Fixing points	The Mounting frame is equipped with four fixing points for suspension using shackles.
[3]	Rear link	Rear link including Fixing bolt [3a] and Ring cotter [3b] . In connection with the Front links of the Vi loudspeaker cabinets, the Rear link of the frame is used to attach the frame to the first cabinet of an array.
[4]	2t Shackle	Three 2t shackle are provided for hoisting purposes.

2.1.2 Z5387.001 Vi Mounting frame bottom

Intended use

The Z5387.001 Vi Mounting frame bottom is designed as a pullback device to fix and/or pull back an array with either the Z5387.000 Vi Mounting frame top or the Z5380 V Flying frame mounted on top of the array.

Alternatively, the frame can be used as an adapter frame to be attached underneath SUB cabinets in mixed array configurations with the Z5380 V Flying frame mounted on top of the array. This allows a maximum of up to 4 x Vi-TOP cabinets to be attached underneath SUB cabinets.

Note: A detailed description of the Z5380 V Flying frame including the relevant assembly instructions is given in the V-Series Rigging manual, which is supplied with the V Flying frame.

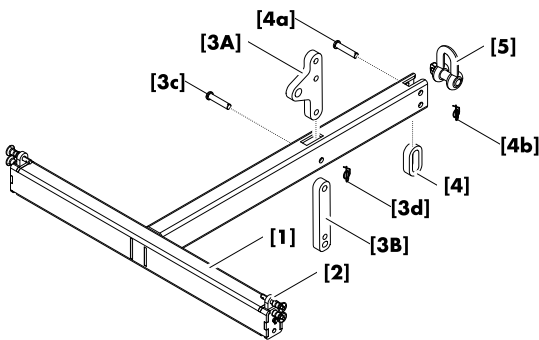
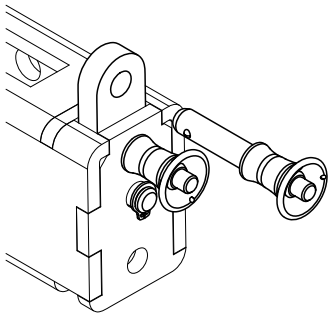
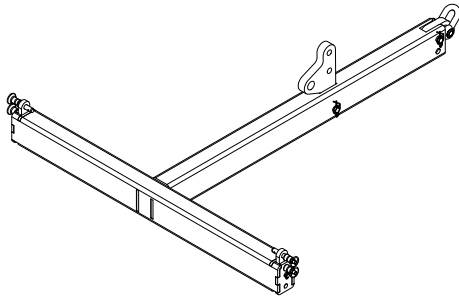

NOTICE!

Construction notes

Each side of the tie bar at the front end of the frame is equipped with a Front link. Both Front links are undetachably attached to the tie bar using a fixing bolt. Directly above each of these fixing bolts there is a Locking pin that serves to additionally stabilize the Front link in its recess. For safety reasons, this Locking pin must always be inserted and locked.

In addition, there is a second Locking pin on each side of the tie bar which is used to connect the frame with a cabinet.

Scope of supply

Please verify the shipment for completeness and proper condition of the items.

The Z5387.001 Vi Mounting frame bottom is equipped and supplied with the following rigging components.

Note: In delivered condition, the Rear link [3] and the O-ring [4] are not attached to the frame. For assembly instructions please refer to ⇒ Chapter 2.4 "Rear/Splay links of the frames" ⇒ Attaching the Splay/Rear links and the O-ring on page 13.

Pos.	Component	Description
[1]	Z5387.001 Vi Mounting frame bottom	Weight (including all rigging components): 9.5 kg (21 lb).
[2]	Front links	The Mounting frame is equipped with two Front links including the corresponding Locking pins.
[3A]	Rear link	In connection with the Front links, this rear link is used to attach the frame underneath the last cabinet of an array.
[3B]	Splay link (0°)	In connection with the Front links, this additional splay link is used to attach the first TOP cabinet at 0° underneath SUB cabinets in a mixed array configuration with SUB cabinets at the top of the array.
[3c/d]		Fixing bolt [3c] and Ring cotter [3d].
[4]	O-ring	Including Fixing bolt [4a] and Ring cotter [4b].
[5]	2t Shackle	Additional 2t shackle.

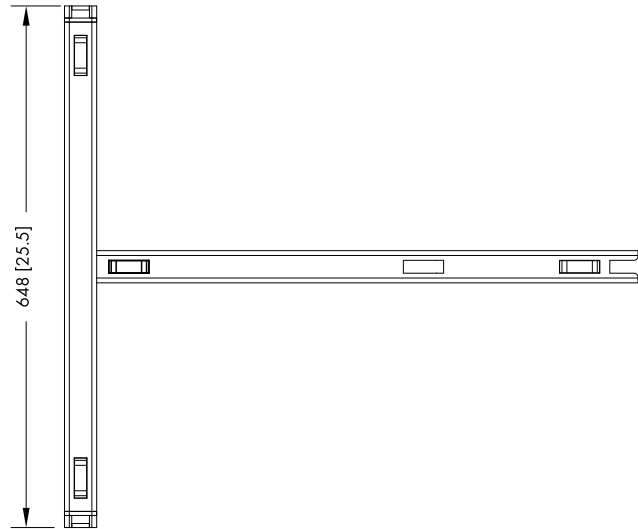
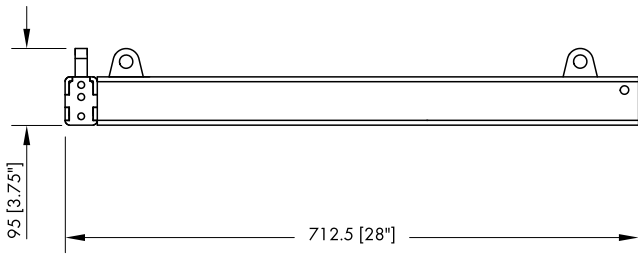

Fig. 1: Z5387.000 Vi Mounting frame top, dimensions in mm [inch]

2.1.3 Dimensional drawings

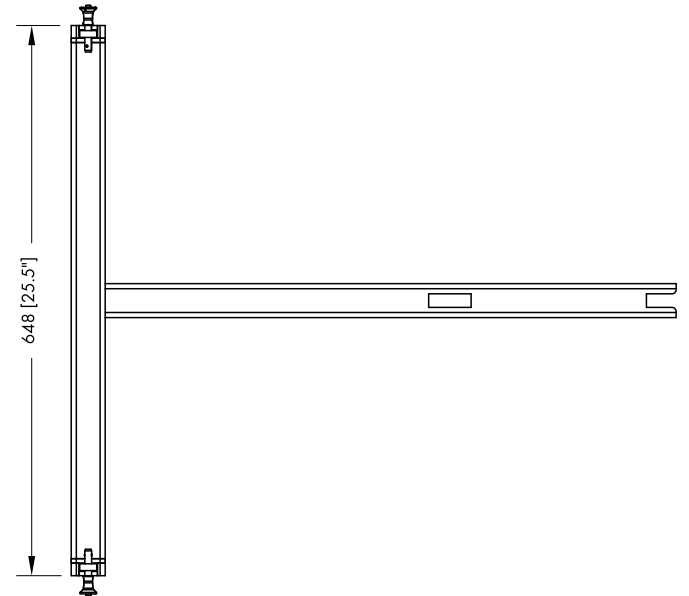
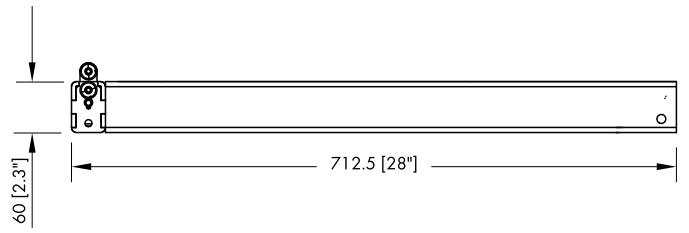

Fig. 2: Z5387.001 Vi Mounting frame bottom, dimensions in mm [inch]

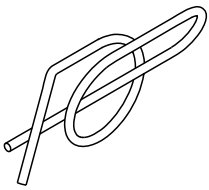

Fig. 3: Ring cotter

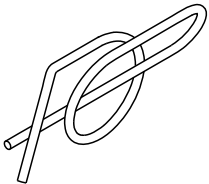
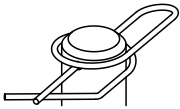
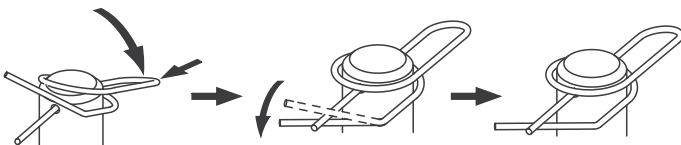
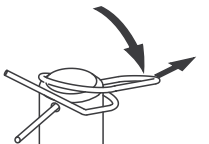
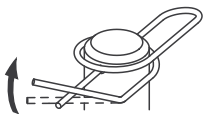

Fig. 4: Ring cotter



Ring cotter locked



2.2 Ring cotters

In connection with the V-Series rigging system, ring cotters are used for the following items to prevent the respective item from slackening and/or loosening:

- Fixing bolt of the SUB cabinet's Rear link.
- Fixing bolt of the frame's Splay link and cable pick.
- Fixing bolt of the 2 t shackles attached to the Load adapters and safety points of the Flying frame.
- Fixing bolt of the Z5147 Rota clamp.

In connection with the Vi rigging system, ring cotters are used for the following items to prevent the respective item from slackening and/or loosening:

- Fixing bolt of the TOP and SUB cabinet's Rear links.
- Fixing bolt of the frame's Rear links and cable picks.

Function of the ring cotter

By default, the ring cotters are "locked" to prevent them from loosening.

For modification reasons such as altering the position of the frame's Splay link or exchanging a shackle, it may be necessary to temporarily remove the cotter and reattach it afterwards.

Note: Please also refer to , , .

For this purpose proceed as follows:

1. **Unlock**
Unlock the ring cotter by pushing up the front wire loop over the straight wire shaft.
2. **Release and remove**
Push down the rear wire loop until the ring cotter snaps over the edge of the bolt and remove the ring cotter.
3. **Refit and lock**
Refit the ring cotter by pushing the straight wire shaft through the hole and pressing the front wire loop underneath the straight wire shaft.

2.3 Locking pins



WARNING!

Potential risk of personal injury and/or damage to material!

The steel wires between the Locking pins of the cabinets and rigging components are not intended to carry any load. The cabinet's weight must only be carried by the Front and Splay/Rear links in conjunction with the front and rear rigging strands of the loudspeaker cabinets and the Mounting/Flying frames.

Ensure all Locking pins are fully inserted and securely locked before lifting any load.

The Vi loudspeaker cabinets are equipped with two types of Locking pins:

Type [B] Locking pin 9 x 40 mm.
Used for the cabinet's Splay/Rear links.

Type [C] Locking pin 8 x 23 mm.
Used for the Front links of the loudspeaker cabinets and the Z5387.001 Vi Mounting frame bottom.

Note: The Locking pins are undetachably attached to the different rigging components on the cabinet and the frames using steel wires.

Throughout this manual these steel wires are not shown in the corresponding illustrations.

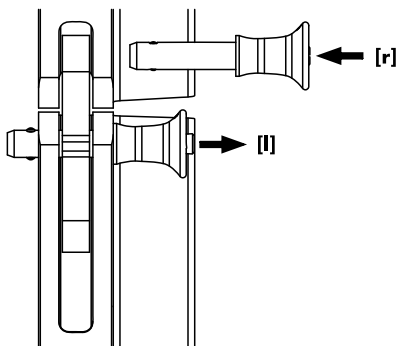
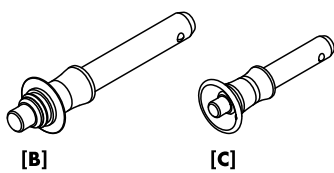

Fig. 5: Locking pin assembly
Shown with pin type [C]

Assembly

The quick lock mechanism applies to all types of Locking pins listed above. To attach the Locking pin proceed as follows:

1. Press the button to **release** the locking mechanism (← [r]).
2. Insert the Locking pin through the respective link or socket until it is fixed in place.
3. Release the button to **lock** the pin (→ [l]).
4. Recheck the Locking pin is securely locked by briefly pulling the Locking pin towards you.
 - ↳ To release and remove the Locking pins, proceed in reverse order.

2.4 Rear/Splay links of the frames



WARNING!

Potential risk of personal injury and/or damage to material!

The fixing bolt [B] is a safety-relevant item.

It is essential that the bolt is fitted correctly and secured by a locked ring cotter [C].

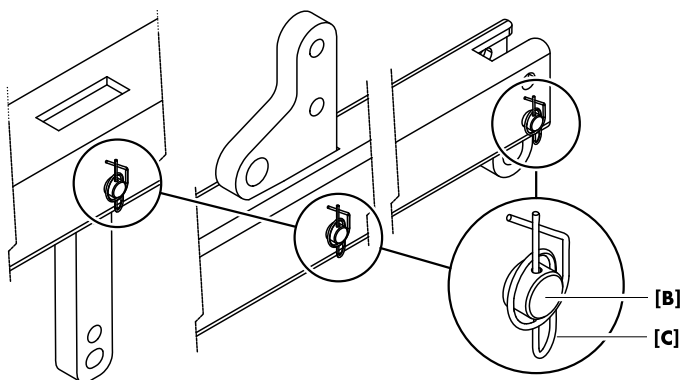

Splay/Rear link positions

The position of the frame's Rear link depends on the type of cabinet (Vi8/Vi12 or Vi-SUB) that is to be attached to the corresponding Mounting frame.

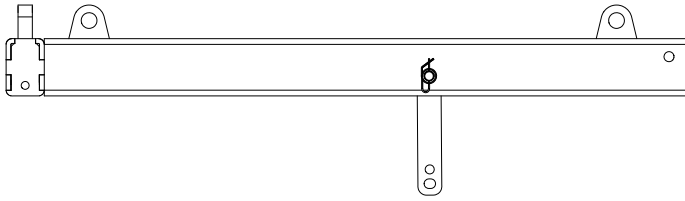

Fig. 6: Splay link of the Z5387.000 Vi Mounting frame top TOP position

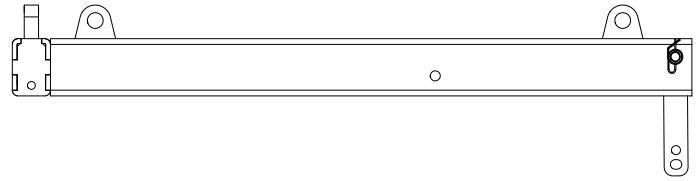

Fig. 7: Splay link of the Z5387.000 Vi Mounting frame top SUB position

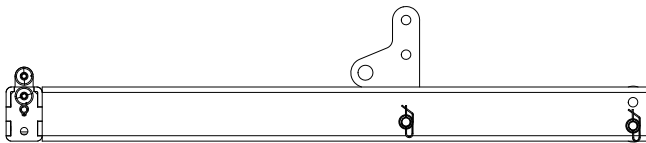

Fig. 8: Rear link of the Z5387.001 Vi Mounting frame bottom TOP position

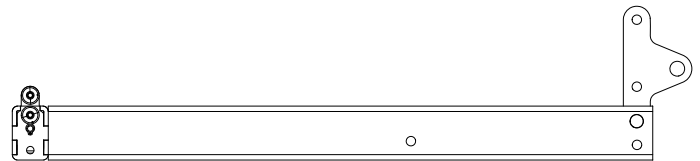

Fig. 9: Rear link of the Z5387.001 Vi Mounting frame bottom SUB position

Attaching the Splay/Rear links and the O-ring

The assembly of both the Rear links and the O-ring is carried out in the following manner:

1. Attach the corresponding item to its dedicated position.

Note: In connection with the bottom frame's Rear link, observe the direction of attachment as shown in the previous section ⇒ "Splay/Rear link positions" on page 12, following Fig. 8 and Fig. 9.

2. Insert the Fixing bolt.
3. Insert and lock the Ring cotter.

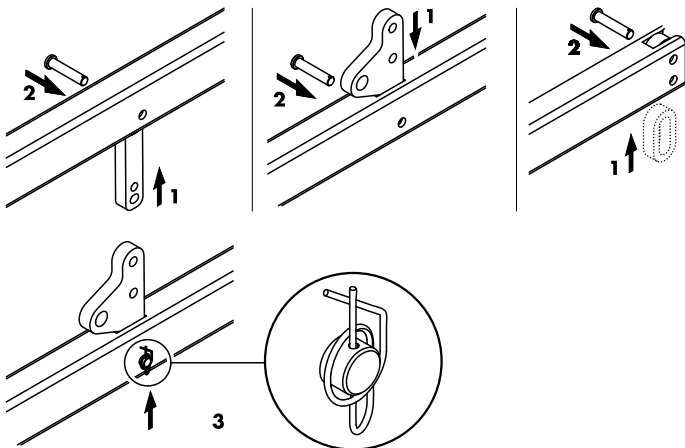

Changing the Splay/Rear link position on Vi Mounting frames

To change the Rear link position, follow the previous assembly instructions in reverse order. The procedure for the top frame is described as an example. The same procedure applies to the bottom frame.

However, in connection with the bottom frame's Rear link, observe the direction of attachment as shown in the previous section ⇒ "Splay/Rear link positions" on page 12, following Fig. 6 and Fig. 7.

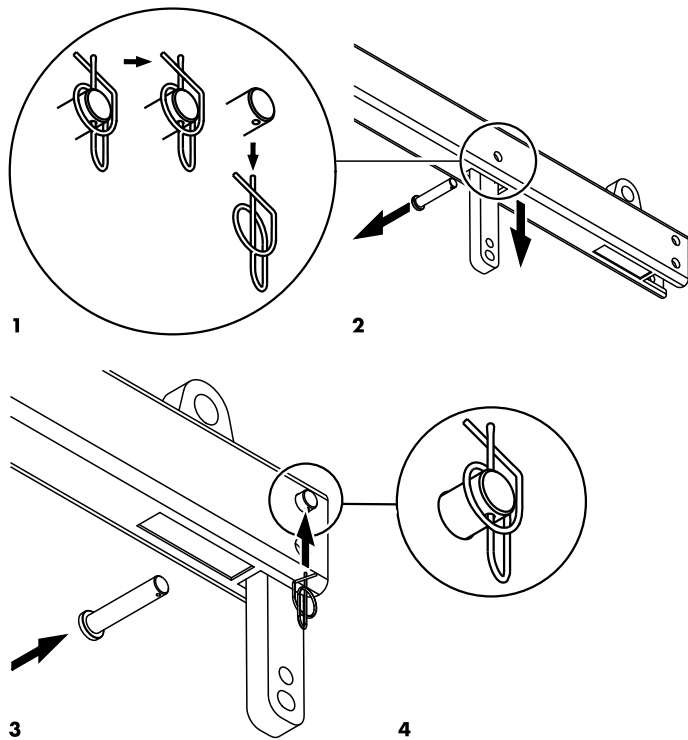

1. Unlock and remove the ring cotter of the fixing bolt.
2. Pull out the fixing bolt and remove the Rear link.
3. Attach the Rear link to its new position and insert the fixing bolt.
4. Secure the fixing bolt using the ring cotter and ensure the ring cotter is properly locked.

2.5 Cabinet's rigging mechanism

Vi cabinets are mechanically connected to the Mounting/Flying frame and subsequent loudspeakers using the Front links attached to both sides of the cabinet front and the central Splay/Rear link at the rear of the cabinet.

All necessary rigging components are mounted to the cabinet and slide out when needed.

In principle, the Front and Splay/Rear link mechanism applies to both the Vi8/Vi12 and Vi-SUB cabinets.

2.5.1 Front link mechanism

Vi8/Vi12 cabinets

1. Release both Locking pins and slide out the Front link.
2. Insert and lock one Locking pin to fix the link in place.

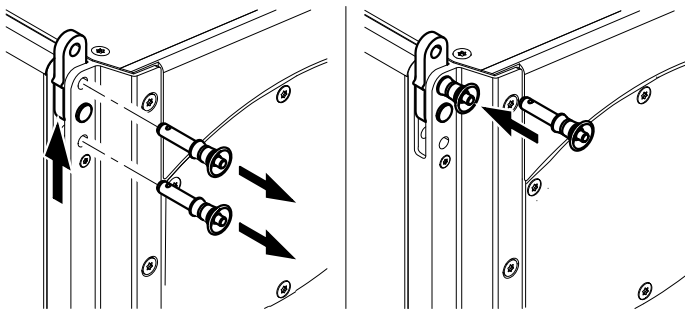

Fig. 10: Front link mechanism of Vi8/Vi12 cabinets

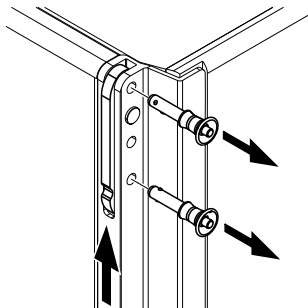

Fig. 11: Front link mechanism of Vi-SUB cabinets

Vi-SUB cabinets

The Front link mechanism of the Vi-SUB cabinets provides four different settings:

- a. SUB to Frame (⇒ Fig. 12)
- b. SUB to SUB with 0° splay between the cabinets (⇒ Fig. 13).
- c. SUB to SUB with 2.5° splay (free ⇒ Fig. 14) between the cabinets.
- d. SUB to SUB with 2.5° splay (blocked ⇒ Fig. 15) between the cabinets.

This setting is used to prevent the cabinets from folding up.

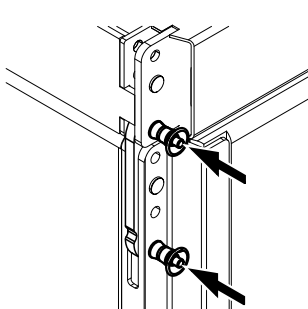

Fig. 12: SUB to Frame

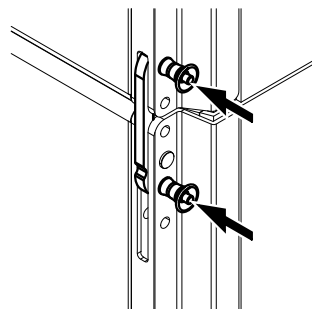

Fig. 13: SUB to SUB, 0° splay

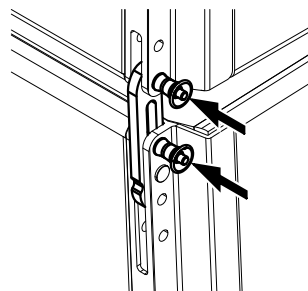

Fig. 14: SUB to SUB, 2.5° splay, free

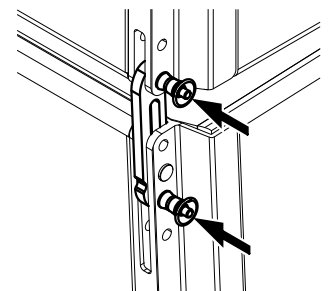

Fig. 15: SUB to SUB, 2.5° splay, blocked

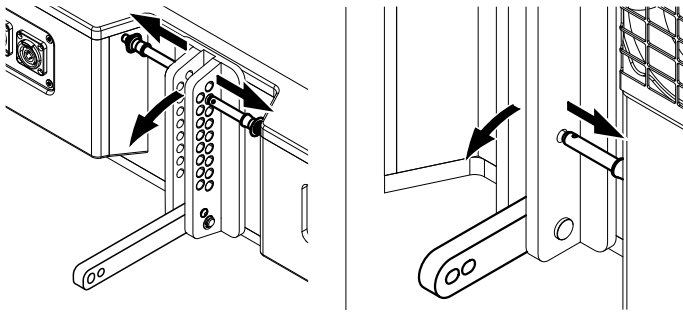

Fig. 16: Splay/Rear link mechanism

2.5.2 Splay/Rear link mechanism

Release the respective Locking pin(s) and fold out the Splay/Rear link.

2.5.3 Setting splay angles for Vi-TOP cabinets

NOTICE!

The rigging system is designed as an intrinsically safe system. For this reason, the second Locking pin (Safety pin **[S]**) must always be inserted.

The splay angles between adjacent cabinets can be set in the range from 0° to 14° in 1° steps. The splay angles are set at the central rear rigging strands of the cabinets.

Vi8/Vi12 cabinets

The Splay link of the Vi-TOP cabinets is designed as a straight link with two holes.

The inner hole defines the splay angle while the outer elongated hole is used for the second Locking pin (Safety pin **[S]**) as shown in the graphic opposite.

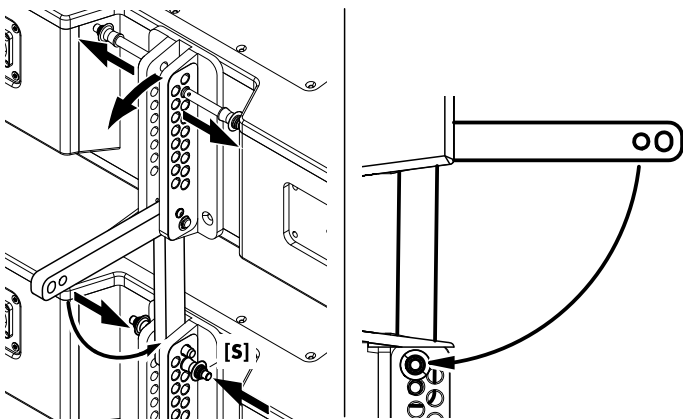

Fig. 17: Set splay angle (e.g. 0°)

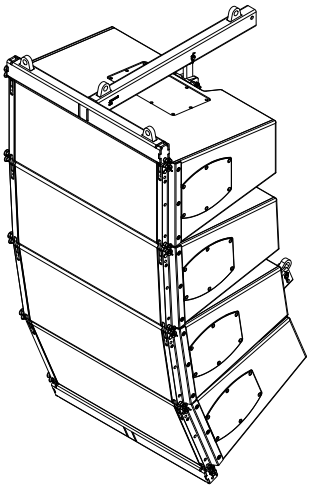

Fig. 18: Vi8/Vi12 array 4-deep

For assembly instructions, please refer to:
⇒ Chapter 3.2 "Vi8/Vi12 Array" on page 18

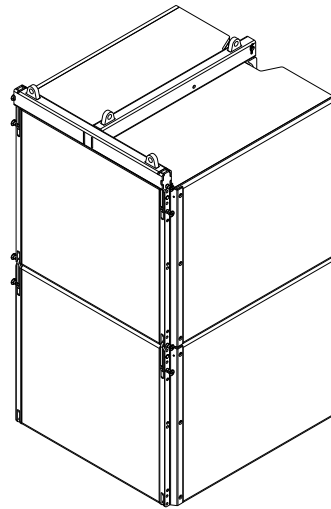

Fig. 19: Vi-SUB column 2-deep

For assembly instructions, please refer to:
⇒ Chapter 3.3 "Vi-SUB Column" on page 21

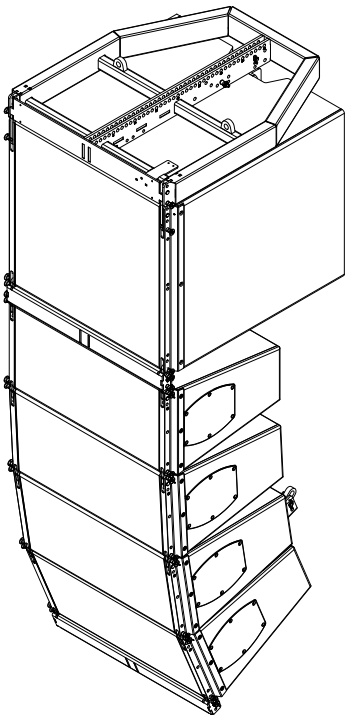

Fig. 20: Mixed array

For assembly instructions, please refer to:
⇒ Chapter 3.4 "Mixed array" on page 24

3.1 Setup preparation

Check the acoustical and mechanical setup using ArrayCalc and prepare enough printouts for each array.

The plan enables the riggers to set up the suspension points, the securing points and the chain hoists.

When on site first:

- Clear the working areas and ensure there is enough space to set up and lift the array.
- Check that the hoists are exactly in the specified position.
- Ensure the chains are not twisted.

Inspections before setup

Before setting up the array, carry out a visual inspection of all system components for faults. This also includes the loudspeakers and in particular the rigging parts of the cabinets (Front and Splay/Rear links).

Damaged components must be withdrawn from use immediately.

Please follow the instructions given in ⇒ Chapter 6 "Care and maintenance / Disposal" on page 33.

3.2 Vi8/Vi12 Array

Remarks and limitations

In combination with the Z5387.000 Vi Mounting frame top, a maximum of 4 x Vi-TOP cabinets can be flown.

To fly more than 4 x Vi-TOP cabinets, the Z5380 V Flying frame must be used.

In this case, please follow the assembly instructions given in the V-Series Rigging manual, which is supplied with the V Flying frame. In the manual, refer to "Flown array, section V8/V12 Array".

Preparations

For this type of setup the Rear link of the mounting frame must be attached to the TOP position. Check the position and alter it if necessary as described in ⇒ Chapter 2 "Rigging concept and components", ⇒ 2.4 "Rear/Splay links of the frames" .

Note: Observe the direction of attachment as shown in the graphic opposite.

1. Prepare the first cabinet

Prepare the Front and Splay links of the first cabinet as described in ⇒ Chapter 2 "Rigging concept and components", ⇒ "Cabinet's rigging mechanism" .

2. Attach the Mounting frame to the first cabinet

1. Lower the frame onto the cabinet until ...
 - the Front links fit into the slots at the front of the frame.
 - the Rear link of the frame fits into the rear rigging strand of the cabinet.
2. Insert and lock the second Locking pins of the cabinet's Front links on both sides.

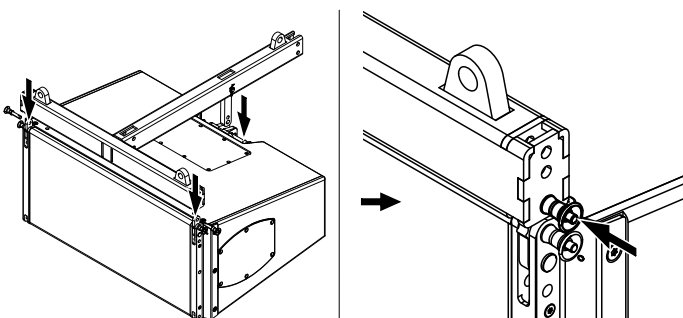
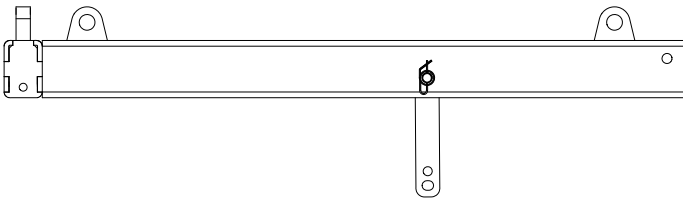

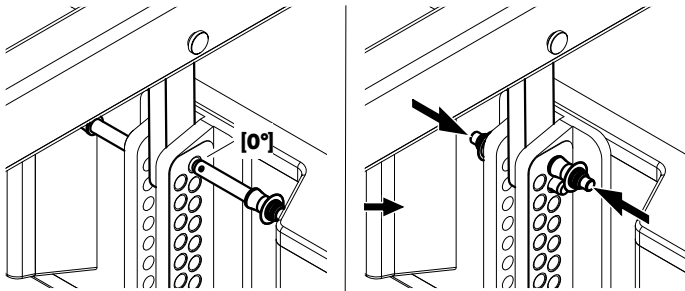

3. At the rear, align the inner hole of the Rear link with the **[0°]** hole of the rear rigging strand.
4. Insert the first Locking pin to the **[0°]** hole.
5. Insert the second Locking pin (Safety pin).

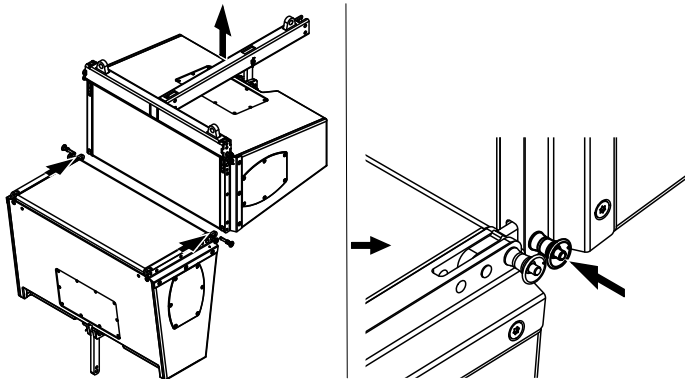

3. Add further cabinets

1. Prepare the Front and Splay links of the next cabinet as described in ⇒ Chapter 2 "Rigging concept and components", ⇒ "Cabinet's rigging mechanism" .
2. Lift the assembly to a suitable working height.
3. Attach the prepared cabinet to the corresponding slots on the front of the upper cabinet.
4. Insert and lock the second Locking pins of the cabinet's Front links on both sides.

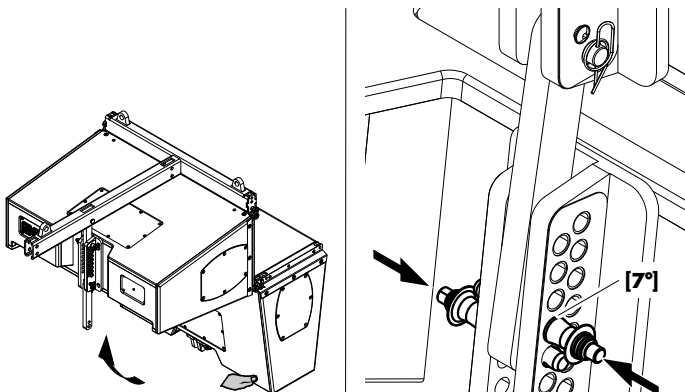

5. Raise the bottom cabinet until the Splay link of the upper cabinet fits into the rear rigging strand of the bottom cabinet.
6. Align the inner hole of the Splay link with the appropriate hole for the desired splay angle (e.g. **[7°]**).
7. Insert the first Locking pin to fix the angle and cabinet in place.
8. Insert the second Locking pin (Safety pin).

To add further cabinets, proceed in the same manner until the assembly is completed.

4. Attach the bottom frame

The Z5387.001 Vi Mounting frame bottom is used if the application requires the array to have an overall vertical angle that is not covered by ArrayCalc or cannot be obtained by the intended suspension.

The bottom frame allows the attachment of additional steel wire ropes or hoists.

Note: For this application, please also observe the safety and assembly instructions given in ⇒ Chapter 5 "Hoisting and aiming the array" ⇒ 5.2 "Modifying the vertical aiming of the array" on page 31.

To attach the bottom frame, proceed as follows:

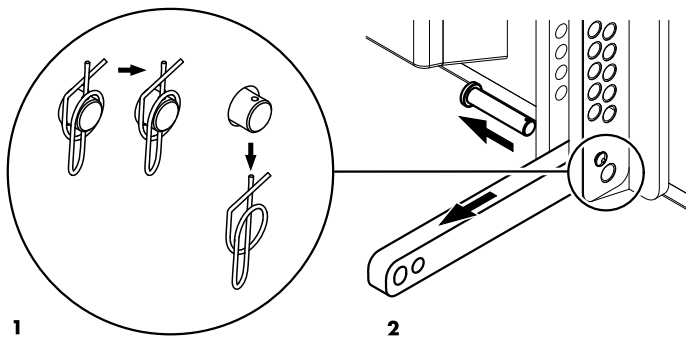

4a. Remove the Splay link

To enable the attachment of the frame, the Splay link of the lowest TOP cabinet must be removed.

1. Unlock and remove the ring cotter of the fixing bolt.
2. Pull out the fixing bolt and take out the Splay link.

Note: Keep the fixing bolt and ring cotter aside. The items are required to fix the Rear link of the frame to the rear rigging strand of the cabinet.

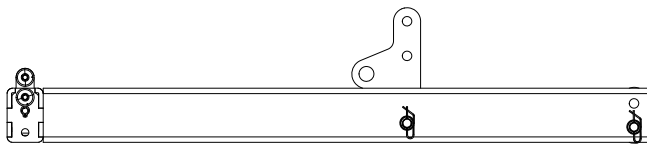

4b. Prepare the bottom frame

The Rear link of the bottom frame must be attached to the TOP position. Check the position and alter it if necessary as described in ⇒ Chapter 2 "Rigging concept and components", ⇒ 2.4 "Rear/Splay links of the frames" .

Note: Observe the direction of attachment as shown in the graphic opposite.

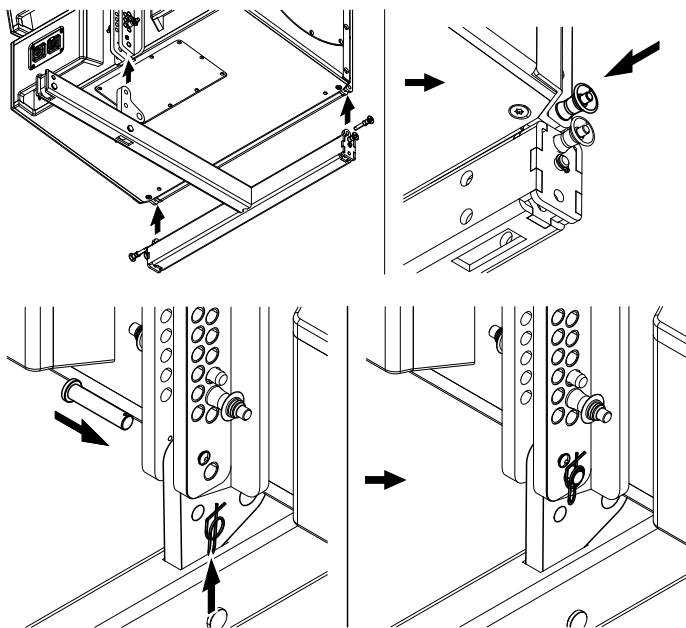

4c. Attach the bottom frame for pullback purposes

1. Lift the assembly to a suitable working height.
2. Release the upper Locking pins of the frame's Front links on both sides.
3. Place the frame underneath the cabinet so that...:
 - the Front links fit into the slots at the front of the cabinet.
 - the Rear link of the frame fits into the rear rigging strand of the cabinet.
4. Insert and lock the upper Locking pins of the frame's Front links on both sides.
5. At the rear, align the Rear link with the hole of the TOP cabinet's Splay link.
6. Reinsert the fixing bolt.
7. Insert and lock the ring cotter.

5. Check the assembly

Before hoisting the array to its operating position, recheck the actual status of the entire assembly according to the checklist given in ⇒ Chapter 4 "Safety and system checks" on page 30.

3.3 Vi-SUB Column

Remarks and limitations

In connection with the Z5387.000 Vi Mounting frame top, a maximum of 2 x Vi-SUB cabinets can be flown.

For more than 2 x Vi-SUB cabinets, the Z5380 V Flying frame must be used.

In this case, please follow the assembly instructions given in the V-Series Rigging manual which is supplied with the V Flying frame. In the manual refer to "Flown array", section "V-SUB Column".

Preparations

For this type of setup the Rear link of the mounting frame must be attached to the SUB position. Check the position and alter it if necessary as described in ⇒ Chapter 2 "Rigging concept and components", ⇒ 2.4 "Rear/Splay links of the frames" .

Note: Observe the direction of attachment as shown in the graphic opposite.

1. Prepare the first cabinet

1. Prepare the Front links of the first cabinet as described in ⇒ Chapter 2 "Rigging concept and components", ⇒ "Cabinet's rigging mechanism" .
2. At the rear top, release both Locking pins.

2. Attach the Mounting frame to the first cabinet

1. Lower the frame onto the cabinet until the Front links fit into the slots at the front of the frame.
2. Insert the second Locking pins of the cabinet's Front links on both sides.
3. At the rear of the cabinet, align the frame's Rear link with the appropriate hole on the rear rigging strand of the cabinet.
4. Reinsert both Locking pins.

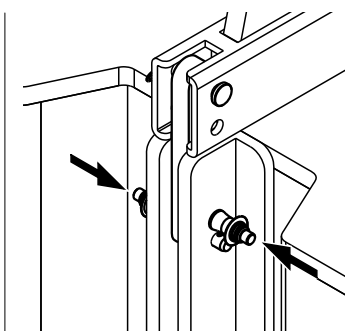
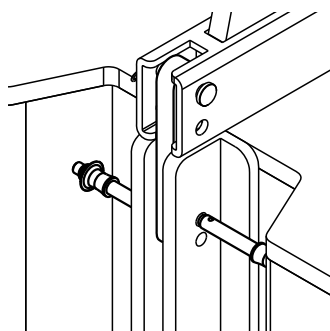
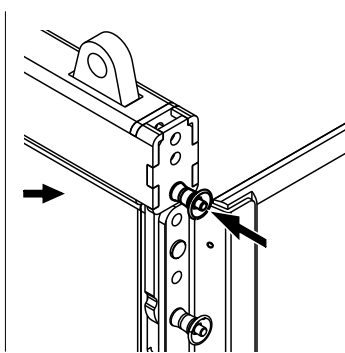
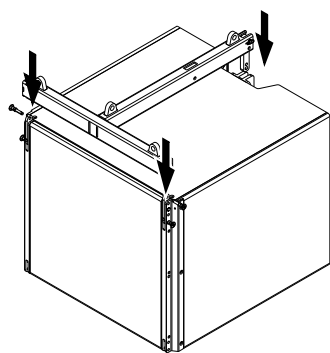
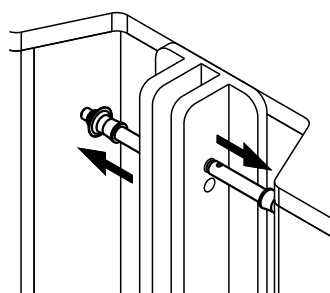
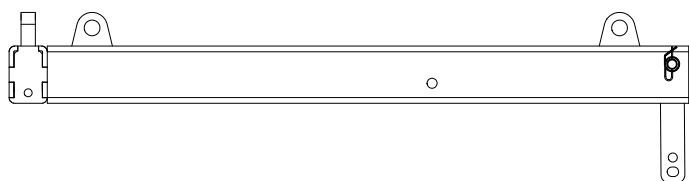

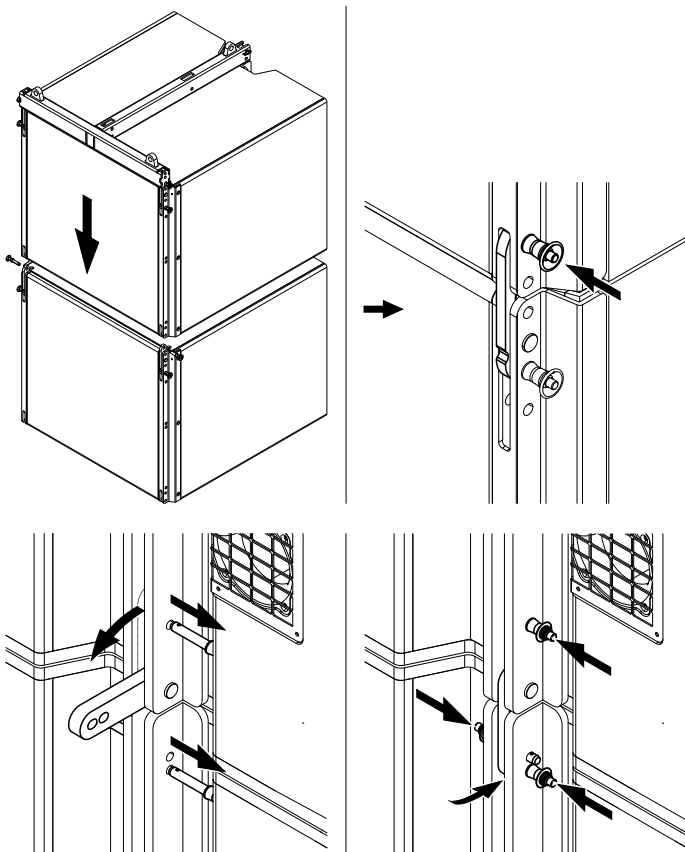

3. Add second/further cabinet(s)

1. Prepare the Front links of the next cabinet as described in ⇒ Chapter 2 "Rigging concept and components", ⇒ "Cabinet's rigging mechanism" on page 15.
2. Lift the current assembly to a suitable working height.
3. Position the next cabinet below the assembly.
4. Lower the assembly onto the cabinet until the Front links of the bottom cabinet fit into the slots of the upper cabinet.
5. Insert the second Locking pins of the cabinet's Front links on both sides.
6. On the rear rigging strand, release the Locking pins of both cabinets.
7. Fold out the Rear link of the upper cabinet.
8. Reinsert the Locking pin on the upper cabinet.
9. Fold the Rear link into the rigging strand of the bottom cabinet.
10. Reinsert the two Locking pins on the bottom cabinet.

4. Attach the bottom frame for pullback purposes

The Z5387.001 Vi Mounting frame bottom is used if the application requires the array to have an overall vertical angle that is not covered by ArrayCalc or cannot be obtained by the intended suspension.

The bottom frame allows the attachment of additional steel wire ropes or hoists.

Note: For this application, please also observe the safety and assembly instructions given in ⇒ Chapter 5 "Hoisting and aiming the array" ⇒ 5.2 "Modifying the vertical aiming of the array" on page 31.

To attach the bottom frame, proceed as follows:

4a. Remove the Rear link

To enable the attachment of the frame, the Rear link of the lowest SUB cabinet must be removed.

1. Unlock and remove the ring cotter of the fixing bolt.
2. Pull out the fixing bolt and take out the Splay link.

Note: Keep the fixing bolt and the ring cotter aside. The items are required to fix the Rear link of the frame to the rear rigging strand of the cabinet.

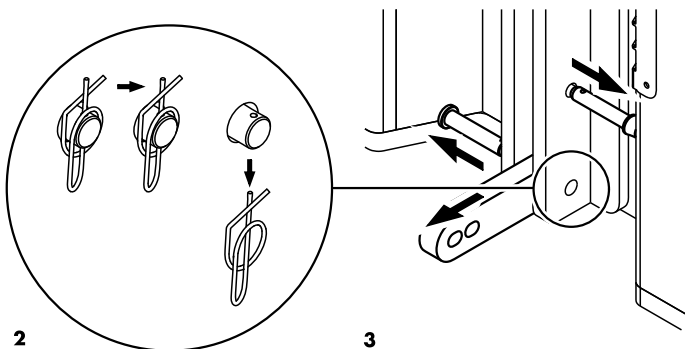

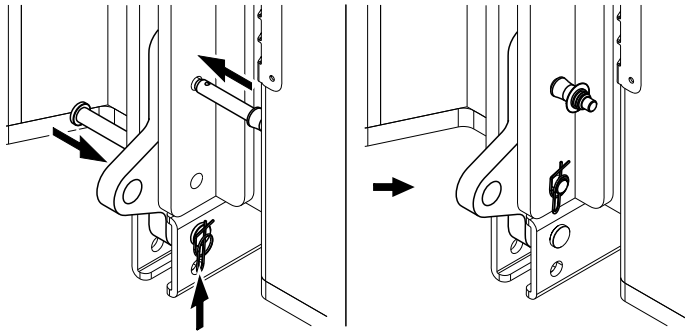
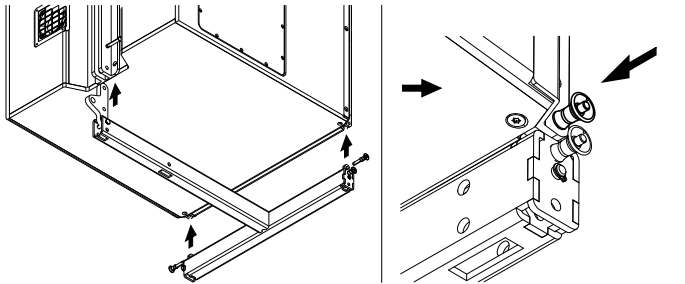
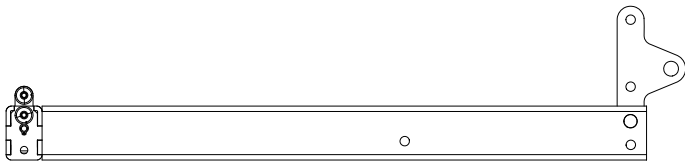

4b. Prepare the bottom frame

The Rear link of the bottom frame must be attached to the SUB position. Check the position and alter it if necessary as described in ⇒ Chapter 2 "Rigging concept and components", ⇒ 2.4 "Rear/Splay links of the frames" .

Note: Observe the direction of attachment as shown in the graphic opposite.

4c. Attach the bottom frame

1. Lift the assembly to a suitable working height.
2. Release the upper Locking pins of the frame's Front links on both sides.
3. Place the frame underneath the cabinet so that...:
 - the Front links fit into the slots at the front of the cabinet.
 - the Rear link of the frame fits into the rear rigging strand of the cabinet.
4. Insert and lock the upper Locking pins of the frame's Front links on both sides.
5. At the rear, align the Rear link with the hole of the SUB cabinet's Splay link.
6. Reinsert the Locking pin
7. Reinsert the fixing bolt.
8. Insert and lock the ring cotter.

5. Check the assembly

Before hoisting the array to its operating position, recheck the actual status of the entire assembly according to the checklist given in ⇒ Chapter 4 "Safety and system checks" on page 30.

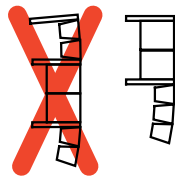

3.4 Mixed array

NOTICE!

If SUB cabinets are included in the array, these must always be positioned at the top of the column.

Remarks and limitations

For a mixed setup, two frames are required. One frame is used for suspension and the second frame acts as an adapter to add Vi8/ Vi12 cabinets below the Vi-SUB cabinets.

NOTICE!

In mixed arrays, the Z5380 V Flying frame must always be used as a suspension device.

For the second frame, there are two options depending on the number of TOP cabinets to be mounted:

- Up to 4 x Vi-TOP cabinets can be mounted underneath the SUB cabinets using the Z5387.001 Vi Mounting frame bottom in addition to the V Flying frame.
- If the array includes more than 4 x Vi-TOP cabinets, an additional Z5380 V Flying frame must be used instead of the Vi Mounting frame bottom.

In this case, please follow the assembly instructions given in the V-Series Rigging manual which is supplied with the V Flying frame. In the manual refer to "Flown array", section "Mixed array".

As a first step to building this type of setup, the Z5380 V Flying frame must be attached at the top of the array. This is done in the following way:

1. Prepare the flying frame

For a mixed type of setup, the Splay link of the V Flying frame must be attached to «POSITION V-SUB». Check the position and alter it if necessary. Proceed as follows:

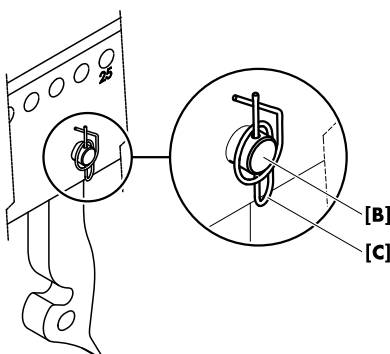
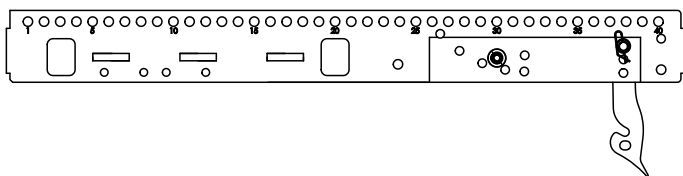

Changing the Splay link position



WARNING!

Potential risk of personal injury and/or damage to material!

The fixing bolt **[B]** of the frame's Splay link bears the full load of the array.

It is essential that the bolt is fitted correctly and secured by a locked ring cotter **[C]**.

To change the Splay link position, proceed as follows:

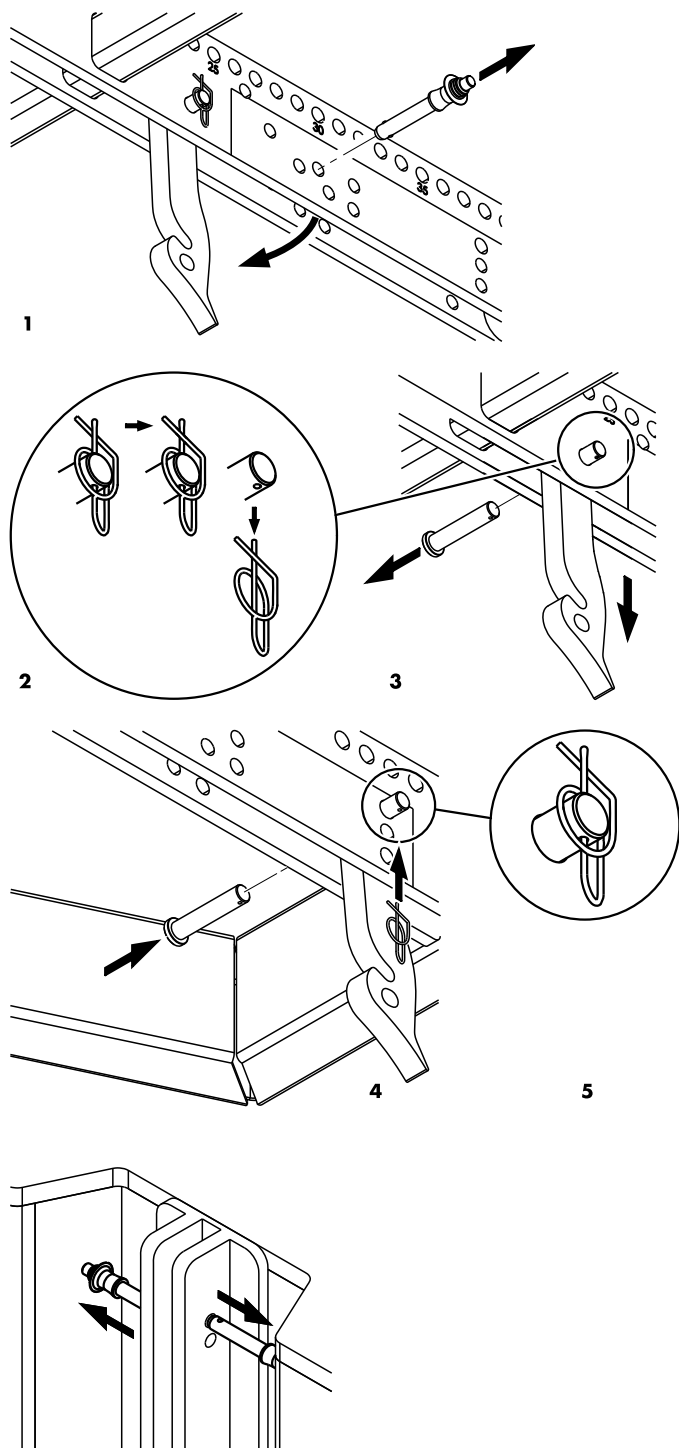

1. Release and remove the Locking pin of the Splay link at park position and fold out the Splay link.

2. Unlock and remove the ring cotter of the fixing bolt.
3. Pull out the fixing bolt and remove the Splay link.

4. Attach the Splay link to its new position and insert the fixing bolt.
5. Secure the fixing bolt using the ring cotter and ensure the ring cotter is properly locked.

2. Prepare the first SUB cabinet

1. Prepare the Front links of the first cabinet as described in
⇒ Chapter 2 "Rigging concept and components",
⇒ "Cabinet's rigging mechanism" .
2. At the rear top, release both Locking pins.

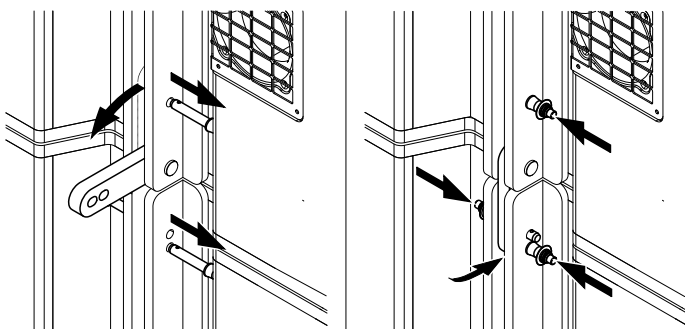
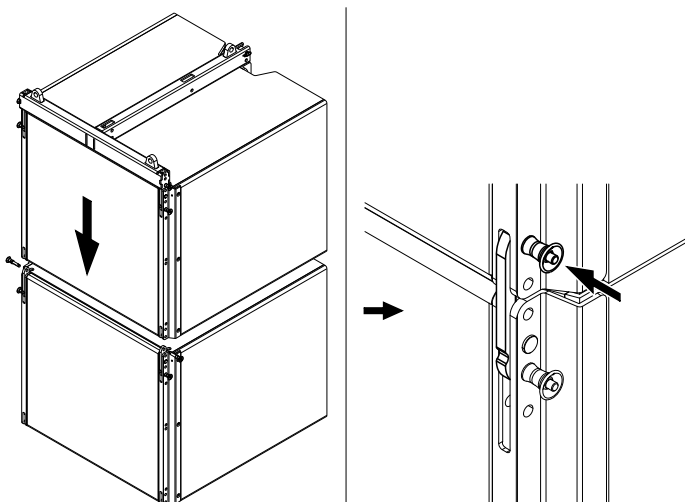
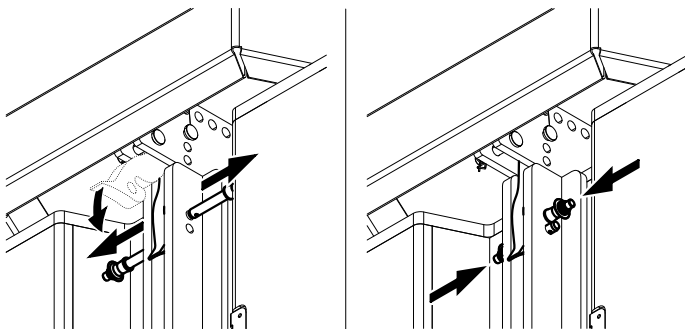
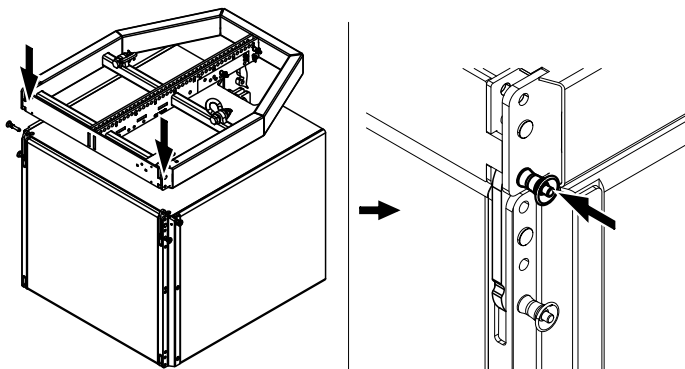

3. Attach the Flying frame to the first SUB cabinet

1. Lower the frame onto the cabinet until the Front links fit into the slots at the front of the frame.
2. Insert the second Locking pins of the cabinet's Front links on both sides.

3. On the rear rigging strand of the cabinet, release both Locking pins.
4. Fold the Splay link into the rigging strand and reinsert the Locking pins.

4. Add further SUB cabinet(s)

If you want to add further SUB cabinets, proceed as follows:

1. Prepare the Front links of the next cabinet as described in ⇒ Chapter 2 "Rigging concept and components", ⇒ "Cabinet's rigging mechanism" on page 15.
2. Lift the current assembly to a suitable working height.
3. Position the next cabinet below the assembly.
4. Lower the assembly onto the cabinet until the Front links of the bottom cabinet fit into the slots of the upper cabinet.
5. Insert the second Locking pins of the cabinet's Front links on both sides.
6. On the rear rigging strand, release the Locking pins of both cabinets.
7. Fold out the Rear link of the upper cabinet.
8. Reinsert the Locking pin on the upper cabinet.
9. Fold the Rear link into the rigging strand of the bottom cabinet.
10. Reinsert the two Locking pins on the bottom cabinet.

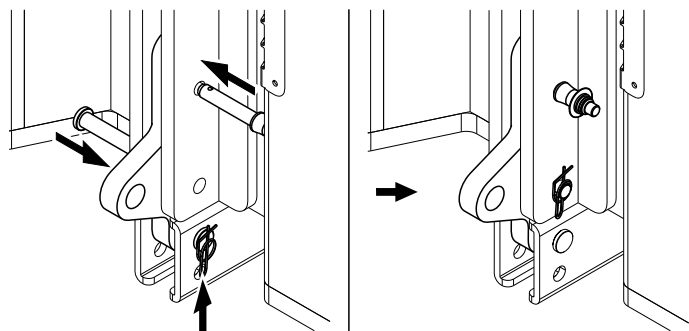
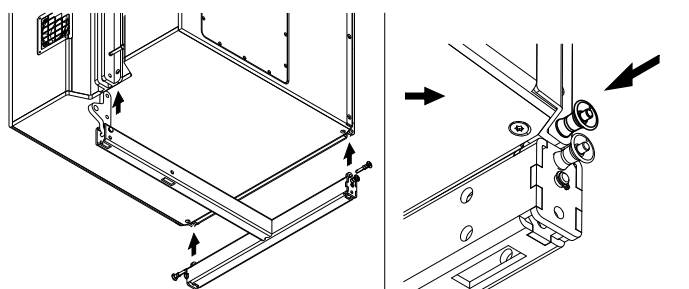
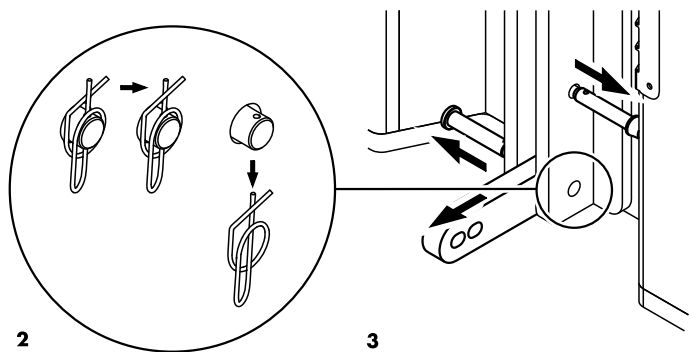
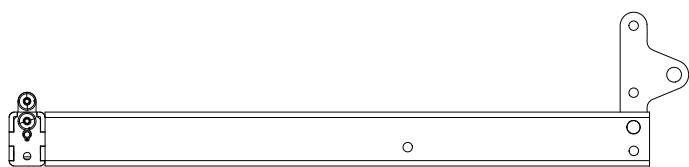

5. Attach the Vi Mounting frame bottom

The Rear link of the bottom frame must be attached to the SUB position. Check the position and alter it if necessary as described in ⇒ Chapter 2 "Rigging concept and components", ⇒ 2.4 "Rear/Splay links of the frames" .

Note: Observe the direction of attachment as shown in the graphic opposite.

5a. Remove the Rear link of the (lowest) SUB cabinet

To enable the attachment of the frame, the Rear link of the lowest SUB cabinet must be removed.

1. Unlock and remove the ring cotter of the fixing bolt.
2. Pull out the fixing bolt and take out the Splay link.

Note: Keep the fixing bolt and the ring cotter aside. The items are required to fix the Rear link of the frame on the rear rigging strand of the cabinet.

5b. Attach the bottom frame

1. Lift the assembly to a suitable working height.
2. Release the upper Locking pins of the frame's Front links on both sides.
3. Place the frame underneath the cabinet so that...:
 - the Front links fit into the slots at the front of the cabinet.
 - the Rear link of the frame fits into the rear rigging strand of the cabinet.
4. Insert and lock the upper Locking pins of the frame's Front links on both sides.
5. At the rear, align the Rear link with the hole of the SUB cabinet's Splay link.
6. Reinsert the Locking pin
7. Reinsert the fixing bolt.
8. Insert and lock the ring cotter.

6. Add Vi8/Vi12 cabinets below the SUB cabinet(s)

Adding Vi8/Vi12 cabinets below the SUBs is a similar procedure to setting up a flown Vi8/Vi12 array as described in ⇒ Chapter 3.2 "Vi8/Vi12 Array" on page 18.

However, to attach the first TOP cabinet underneath the frame, use the additional Splay link of the frame ("Z5387.001 - Pos. 3B").

⇒ Attach the Splay link to the frame correspondingly.

To add further TOP cabinets, proceed in the same manner as described in ⇒ Chapter 3.2 "Vi8/Vi12 Array" on page 18.

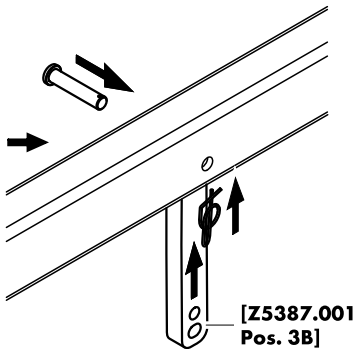

7. Attach a further bottom frame for pullback purposes

The Z5387.001 Vi Mounting frame bottom is used if the application requires the array to have an overall vertical angle that is not covered by ArrayCalc or cannot be obtained by the intended suspension.

The bottom frame allows the attachment of additional steel wire ropes or hoists.

Note: For this application, please also observe the safety and assembly instructions given in ⇒ Chapter 5 "Hoisting and aiming the array" ⇒ 5.2 "Modifying the vertical aiming of the array" on page 31.

To attach the bottom frame, proceed as follows:

7a. Remove the Splay link

To enable the attachment of the frame, the Splay link of the lowest TOP cabinet must be removed.

1. Unlock and remove the ring cotter of the fixing bolt.
2. Pull out the fixing bolt and take out the Splay link.

Note: Keep the fixing bolt and the ring cotter aside. The items are required to fix the Rear link of the frame to the rear rigging strand of the cabinet.

7b. Prepare the bottom frame

The Rear link of the bottom frame must be attached to the TOP position. Check the position and alter it if necessary as described in ⇒ Chapter 2 "Rigging concept and components", ⇒ 2.4 "Rear/Splay links of the frames" .

Note: Observe the direction of attachment as shown in the graphic opposite.

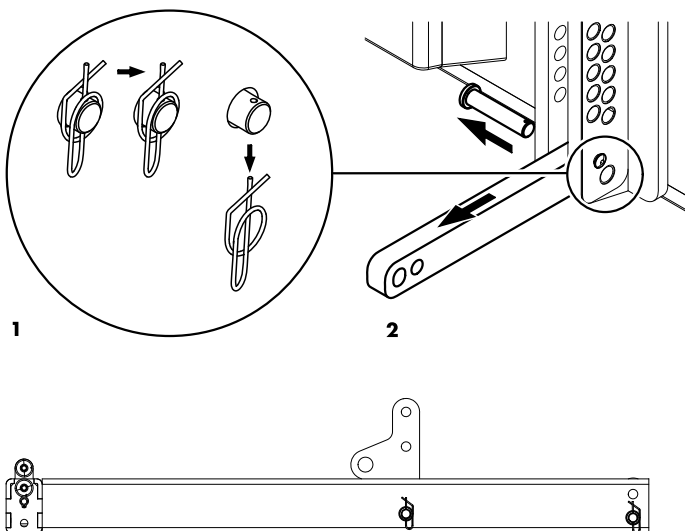

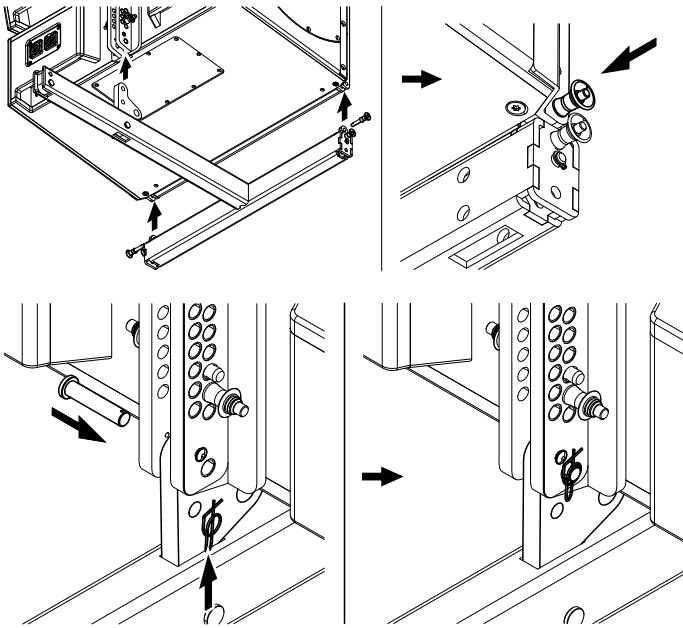

7c. Attach the bottom frame

1. Lift the assembly to a suitable working height.
2. Release the upper Locking pins of the frame's Front links on both sides.
3. Place the frame underneath the cabinet so that...:
 - the Front links fit into the slots at the front of the cabinet.
 - the Rear link of the frame fits into the rear rigging strand of the cabinet.
4. Insert and lock the upper Locking pins of the frame's Front links on both sides.
5. At the rear, align the Rear link with the hole of the TOP cabinet's Splay link.
6. Reinsert the fixing bolt.
7. Insert and lock the ring cotter.

8. Check the assembly

Before hoisting the array to its operating position, recheck the actual status of the entire assembly according to the checklist given in ⇒ Chapter 4 "Safety and system checks" on page 30.

Before hoisting the array to its operating position, recheck the actual status of the assembly as follows:

4.1 Mechanical setup

- Check the attachment of the Mounting/Flying frame(s) to the cabinets:
 - Ensure all Locking pins are properly inserted and locked.
 - Ensure all Fixing bolts are properly fitted and secured by a locked Ring cotter.
- Check the attachment of all Front links on both sides of the cabinets and ensure all Locking pins are properly inserted and locked.
- Check the splay angles and the attachment of the Splay/Rear links on the rear of the cabinets:
 - Ensure all Locking pins are properly inserted and locked.
 - Ensure all Fixing bolts are properly fitted and secured by a locked Ring cotter.

4.2 Wiring

- Check the wiring.
If the amplifiers are already wired and powered on, use their System check functions or Channel mute switches and a test signal to check the correct operation and routing of all channels and cabinets.

5.1 Hoisting the array



WARNING!
Potential risk of personal injury and/or damage to material!

Always ensure that each of the hoists is able to carry the total weight of the array.

When hoisting the array, unpredictable dynamic forces as well as swinging of the array must be taken into account. This may lead to personal injury and/or damage to the rigging components and loudspeaker cabinets.

Ensure there is nobody directly underneath or in the vicinity of the load who is not involved in the setup.

When all the mechanical adjustments, system checks and safety checks have been made, the array can be hoisted up to its operating position and firmly attached to the onsite roof construction.

The chain hoist motors must raise the system slowly and evenly so that it does not swing or move from side to side during hoisting.

5.2 Modifying the vertical aiming of the array

The Z5387.001 Vi Mounting frame bottom is used if the application requires the array to have an overall vertical angle that is not covered by ArrayCalc or cannot be obtained by the intended suspension.

The bottom frame allows the attachment of additional steel wire ropes or hoists.



WARNING!
Potential risk of personal injury and material damage!

Using additional wires or hoists changes the load conditions within the array and its rigging components. The load calculated using ArrayCalc no longer applies. For this reason, increasing the vertical angle of an array requires individual considerations and calculations based on the relevant onsite conditions.

Always pull the additional wires or hoists to the back and upwards, as shown in the graphic opposite.

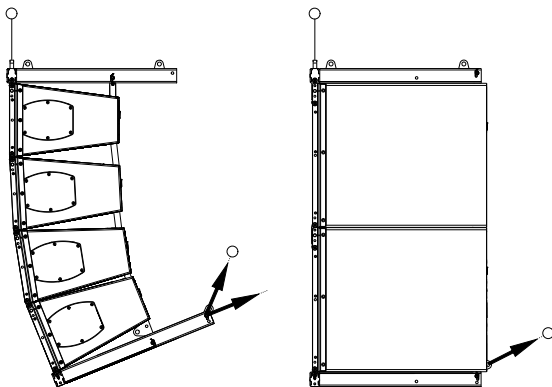

Fig. 21: Z5387.001 Vi Mounting frame bottom serving to increase the overall vertical angle of the array

5.2.1 Dedicated fixing points

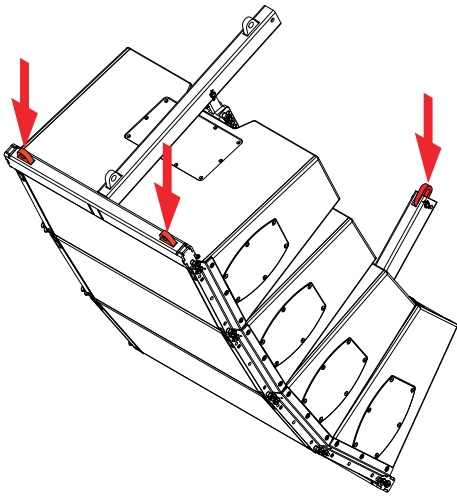

Fig. 22: Vi8/Vi12 array 4-deep

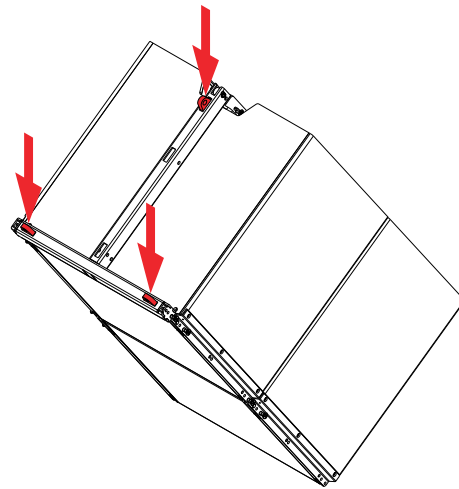

Fig. 23: Vi-SUB column 2-deep

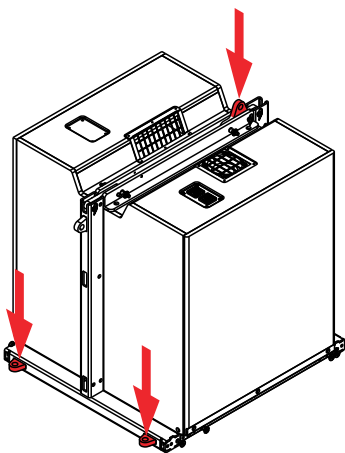

Fig. 24: Vi-SUB assembly

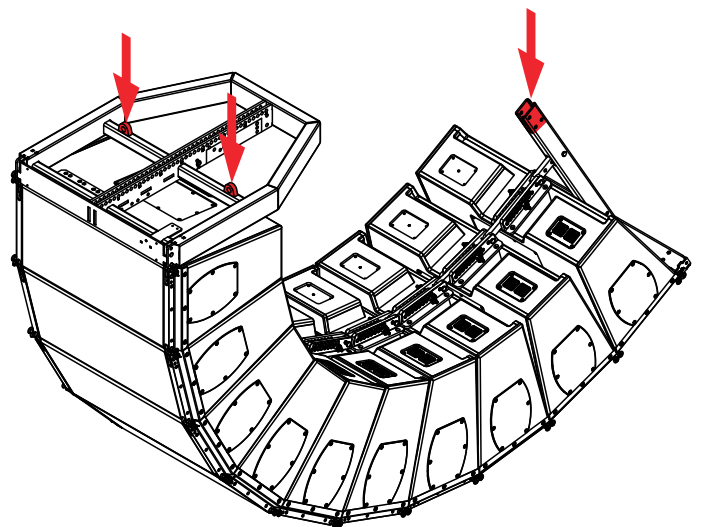

Fig. 25: Vi8/Vi12 array 10-deep

6.1 Visual and functional inspection

**WARNING!**

Potential risk of personal injury and/or damage to material

To eliminate the potential risk of accident due to malfunctioning of a component, regularly inspect all system components.

Cabinet enclosure

- Visual inspection of all fitting plates for obvious damage (e.g. cracks or corrosion).
- Visual inspection of the rear rigging strand for obvious damage (e.g. cracks, deformation or corrosion) including all drilled holes of the component.
- Inspection of all fitting plates including front grills to ensure they are securely attached.

Front and Splay (Rear) links

Visual inspection regarding deformation and damage (e.g. cracks and corrosion) including all drilled holes of the component.

Locking pins

Visual inspection for deformation, cracks and corrosion of the component.

Flying and Mounting frames

Visual inspection regarding deformation and damage (e.g. cracks and corrosion) including all drilled holes of the component.

6.2 Disposal

When out of use the rigging components must be disposed of in accordance with the national environmental regulations.

Ensure that damaged rigging components are disposed of in a way that they cannot be used again.



7.1 EU conformity (CE symbol)

This declaration applies to:

d&b Loudspeaker cabinets

(With integrated rigging components.)

- Z0535, Vi8
- Z0536, Vi12
- Z0538, Vi-SUB

d&b Rigging components

(Including all additional components.)

- Z5387.000, Vi Mounting frame top
- Z5387.001, Vi Mounting frame bottom
- Z5380.901, V Flying frame SC

by d&b audiotechnik GmbH & Co. KG.

All product variants are included, provided they correspond to the original technical version and have not been subject to any later design or electromechanical modifications.

We herewith declare that said products are in conformity with the provisions of the respective EC directives including all applicable amendments.

A detailed declaration is available on request and can be ordered from d&b or downloaded from the d&b website at www.dbaudio.com.

7.2 Disposal

When out of use the rigging components must be disposed of in accordance with the national environmental regulations.

Ensure that damaged rigging components are disposed of in a way that they cannot be used again.



